



INSTALLATION AND OPERATING INSTRUCTIONS

(Applicable to the 9000M2
firmware Ver. 2.00 or later)

9000 Series Power Amplifier

CP-9500M2-EB

Dual CH 500W Digital Mixing Amplifier

A-9500D2-AS 1CE

Please also read the separate instruction manual for the programming software in conjunction with this manual.

Thank you for purchasing TOA's 9000 series Amplifier.

Please carefully follow the instructions in this manual to ensure long, trouble-free use of your equipment.

Note: All the 9000 series in this manual refer to CP-9500M2-EB and A-9500D2-AS 1CE.

TOA Corporation

TABLE OF CONTENTS

1. IMPORTANT SAFETY INSTRUCTIONS	6
2. SAFETY PRECAUTIONS	7
3. GENERAL DESCRIPTION	9
4. FEATURES	10
5. INSTALLATION PRECAUTIONS	11
6. HANDLING PRECAUTIONS	11
7. NOMENCLATURE AND FUNCTIONS(EXAMPLE FOR CP-9500M2-EB)	
7.1. CP-9500M2-EB Amplifier	
[Front]	12
[VFD on-screen indications]	13
[Changing the indicated channels on the LEVEL output meter]	15
[Changing the input and output meter display status]	15
[Rear]	16
7.2. Optional Modules	
7.2.1. D-001T and D-001R (2-channel Input Modules)	17
7.2.2. T-001T (Audio Output Expansion Module)	17
7.2.3. ZP-001T (Zone Paging Module)	18
7.2.4. C-001T (Control I/O Expansion Module)	19
7.2.5. AN-001T (Ambient Noise Sensor Input Module)	19
7.2.6. RC-001T (Remote Control Module)	20
7.3. Optional Accessories	
7.3.1. AN-9001 (Ceiling Mount Microphone)	21
7.3.2. ZM-9001 (Zone Manager)	22
7.3.3. ZM-9002 (Zone Manager)	23
7.3.4. ZM-9003 (Zone Manager)	24
7.3.5. ZM-9011 (Remote Control Panel)	25
7.3.6. ZM-9012 (Remote Control Panel)	26
7.3.7. ZM-9013 (Remote Control Panel)	27
7.3.8. ZM-9014 (Remote Control Panel)	28
7.3.9. SS-9001 (Speaker Selector)	30
8. OPERATION OUTLINE	
8.1. Using as a Mixer Amplifier	31
8.2. Using as a Paging Amplifier	32
8.2.1. Paging using the D-001T, D-001R, or 900 series module	32
8.2.2. Paging using the ZP-001T module	33
8.2.3. Cross point ON/OFF control using the remote controller	36
8.3. Glossary	40

9. OPERATION

9.1. Basic Operation	
9.1.1. Keys and knobs	43
9.1.2. Power ON/OFF	43
9.1.3. Changing the input parameters	43
9.1.4. Changing the output parameters	44
9.1.5. Input channel ON/OFF	44
9.1.6. Output channel ON/OFF	44
9.2. Recalling Scene Memory	45
9.3. Making Zone Paging	
9.3.1. Zone paging using the D-001T, D-001R, or 900 series module	46
9.3.2. Zone paging using the ZP-001T module	48
9.4. Releasing Key Lock	50
9.5. Operation Example	51

10. SETTINGS

10.1. Setting Menu Configuration and Flow for Entering Each Screen	
10.1.1. Input setting configuration	52
10.1.2. Output setting configuration	52
10.1.3. Utility setting configuration	53
10.1.4. Scene memory setting configuration	53
10.1.5. Confirming set items	53
10.2. Input Setting Flow Chart	
10.2.1. Input setting flow chart for the channel on which the D-001T or D-001R is used	54
10.2.2. Input setting flow chart for the channel on which the ZP-001T is used	56
10.2.3. Input setting flow chart for the channel on which the AN-001T is used	57
10.2.4. Input setting items	58
10.3. Output Setting Flow Chart	69
10.3.1. Output setting items	70
10.4. UTILITY Setting Flow Chart	75
10.4.1. Control input terminal's function settings	77
10.4.2. Control output terminal's function settings	77
10.4.3. Utility setting items	78
10.5. Key Lock Function Setting	
10.5.1. Keys that can be locked	90
10.5.2. Password setting	91
10.5.3. Key lock setting operation	92
10.6. SCENE MEMORY Setting Flow Chart	93
10.6.1. Scene memory setting items	94

11. HOW TO STORE OR ERASE SCENE MEMORY

11.1. Recalling Scene Memory	96
11.2. Storing Scene Memory	97
11.3. Erasing Scene Memory	98
11.4. Setting the Scene Memory to be Recalled at Power-On	99

12. RESTORING FACTORY DEFAULT SETTING	100
12.1. Default Setting Table	
12.1.1. Items regarding system settings	101
12.1.2. Items regarding Scene settings	103
12.1.3. Items regarding paging settings	105
13. MODULE INSTALLATION	
13.1. Module Combination	106
13.2. Channel Numbers and Terminal Numbers	106
13.3. Module Installation	106
13.4. Module Installation Examples	108
14. CONNECTIONS(EXAMPLE FOR CP-9500M2-EB)	
14.1. Control I/O Terminal Connections	
14.1.1. When a variable resistor or variable DC power supply unit is connected	109
14.1.2. When the ZM-9001 or ZM-9002 is connected	110
14.1.3. When the ZM-9003 is connected	110
14.1.4. When the SS-9001 is connected	110
14.1.5. Operation by control input	111
14.2. Speaker Output Terminal Connections	112
14.3. C-001T Module Connections	
14.3.1. Control input terminal	112
14.3.2. Control output terminal	112
14.3.3. Connecting the ZM-9003	113
14.3.4. Connecting the SS-9001	113
14.4. RC-001T Module Connection	
14.4.1. Connection method	114
14.4.2. Cable distance	115
14.5. RS-232C Connector Connection	118
14.6. AN-001T and AN-9001 Connections	118
14.7. Power Source Connections to the SS-9001	
14.7.1. When using a 24 V DC power source	119
14.7.2. When using the optional AC adapter	119
14.8. Removable Terminal Plug Connection	120
15. RACK MOUNTING BRACKET ATTACHMENT	121
16. CLEANING THE FILTER	122
17. AN-9001 INSTALLATION	123
18. DIMENSIONAL DIAGRAMS	
18.1. AN-9001	124
18.2. ZM-9001	125
18.3. ZM-9002	125
18.4. ZM-9003	126
18.5. ZM-9011	127
18.6. ZM-9012	127
18.7. ZM-9013	128
18.8. ZM-9014	129
18.9. SS-9001	130

19. OUTLINE OF THE ATTACHED SOFTWARE	131
20. ERROR INDICATIONS	132
21. TROUBLESHOOTING	133
22. BLOCK DIAGRAM	134
23. SIGNAL FLOW DIAGRAM	135
24. LEVEL DIAGRAM	136
25. COMPRESSION CHARACTERISTICS DIAGRAM	137
26. SPEAKER PRESET PARAMETER LIST	138
27. SPECIFICATIONS	
27.1. CP-9500M2-EB AND A-9500D2-AS 1CE	142
27.2. Optional Modules	
27.2.1. D-001T	145
27.2.2. D-001R	146
27.2.3. T-001T	147
27.2.4. C-001T	148
27.2.5. ZP-001T	148
27.2.6. AN-001T	149
27.2.7. RC-001T	149
27.3. Optional Accessories	
27.3.1. AN-9001	150
27.3.2. ZM-9001	150
27.3.3. ZM-9002	151
27.3.4. ZM-9003	151
27.3.5. ZM-9011	152
27.3.6. ZM-9012	152
27.3.7. ZM-9013	153
27.3.8. ZM-9014	153
27.3.9. SS-9001	154

1. IMPORTANT SAFETY INSTRUCTIONS

- Read these instructions.
- Keep these instructions.
- Heed all warnings.
- Follow all instructions.
- Do not use this apparatus near water.
- Clean only with dry cloth.
- Do not block any ventilation openings. Install in accordance with the manufacturer's instructions.
- Do not install near any heat sources such as radiators, heat registers, stoves, or other apparatus (including amplifiers) that produce heat.
- Do not defeat the safety purpose of the polarized or grounding-type plug. A polarized plug has two blades with one wider than the other. A grounding type plug has two blades and a third grounding prong. The wide blade or the third prong are provided for your safety. If the provided plug does not fit into your outlet, consult an electrician for replacement of the obsolete outlet.
- Protect the power cord from being walked on or pinched particularly at plugs, convenience receptacles, and the point where they exit from the apparatus.
- Only use attachments/accessories specified by the manufacturer.
- Use only with the cart, stand, tripod, bracket, or table specified by the manufacturer, or sold with the apparatus. When a cart is used, use caution when moving the cart/apparatus combination to avoid injury from tip-over.



- Unplug this apparatus during lightning storms or when unused for long periods of time.
- Refer all servicing to qualified service personnel. Servicing is required when the apparatus has been damaged in any way, such as power-supply cord or plug is damaged, liquid has been spilled or objects have fallen into the apparatus, the apparatus has been exposed to rain or moisture, does not operate normally, or has been dropped.

2. SAFETY PRECAUTIONS

- Before installation or use, be sure to carefully read all the instructions in this section for correct and safe operation.
- Be sure to follow all the precautionary instructions in this section, which contain important warnings and/or cautions regarding safety.
- After reading, keep this manual handy for future reference.

Safety Symbol and Message Conventions

Safety symbols and messages described below are used in this manual to prevent bodily injury and property damage which could result from mishandling. Before operating your product, read this manual first and understand the safety symbols and messages so you are thoroughly aware of the potential safety hazards.



The exclamation point within an equilateral triangle is intended to alert the user to the presence of important operation and maintenance (servicing) instruction in the literature accompanying the appliance.



WARNING

Indicates a potentially hazardous situation which, if mishandled, could result in death or serious personal injury.

When Installing the Unit

- Do not expose the unit to rain or an environment where it may be splashed by water or other liquids, as doing so may result in fire or electric shock.
- Use the unit only with the voltage specified on the unit. Using a voltage higher than that which is specified may result in fire or electric shock.
- Do not cut, kink, otherwise damage nor modify the power supply cord. In addition, avoid using the power cord in close proximity to heaters, and never place heavy objects -- including the unit itself -- on the power cord, as doing so may result in fire or electric shock.
- Avoid installing or mounting the unit in unstable locations, such as on a rickety table or a slanted surface. Doing so may result in the unit falling down and causing personal injury and/or property damage.
- External wiring connected to the terminals marked with ⚡ requires installation by an instructed person.
- The apparatus shall be connected to a mains socket outlet with a protective earthing connection.
- The socket-outlet shall be installed near the equipment and the plug shall be easily accessible.
- Use the supplied rack mounting bracket when mounting the unit in an equipment rack. Remove four M4 x 8 screws on both sides of the unit, and mount the bracket there using the supplied M4 x 16 screws instead.

When the Unit is in Use

- Should the following irregularity be found during use, immediately switch off the power, disconnect the power supply plug from the AC outlet and contact your nearest TOA dealer. Make no further attempt to operate the unit in this condition as this may cause fire or electric shock.
 - If you detect smoke or a strange smell coming from the unit
 - If water or any metallic object gets into the unit
 - If the unit falls, or the unit case breaks
 - If the power supply cord is damaged (exposure of the core, disconnection, etc.)
 - If it is malfunctioning (no tone sounds.)
- To prevent a fire or electric shock, never open nor remove the unit case as there are high voltage components inside the unit. Refer all servicing to your nearest TOA dealer.
- Do not place cups, bowls, or other containers of liquid or metallic objects on top of the unit. If they accidentally spill into the unit, this may cause a fire or electric shock.



CAUTION

Indicates a potentially hazardous situation which, if mishandled, could result in moderate or minor personal injury, and/or property damage.

When Installing the Unit

- Never plug in nor remove the power supply plug with wet hands, as doing so may cause electric shock.
- When unplugging the power supply cord, be sure to grasp the power supply plug; never pull on the cord itself. Operating the unit with a damaged power supply cord may cause a fire or electric shock.
- Do not block the ventilation slots in the unit's cover. Doing so may cause heat to build up inside the unit and result in fire.
- Avoid installing the unit in humid or dusty locations, in locations exposed to the direct sunlight, near the heaters, or in locations generating sooty smoke or steam as doing otherwise may result in fire or electric shock.
- To avoid electric shocks, be sure to unplug the unit's power supply cord when connecting speakers.
- Be sure to follow the instructions below when rack-mounting the unit. Failure to do so may cause a fire or personal injury.
 - Install the equipment rack on a stable, hard floor. Fix it with anchor bolts or take other arrangements to prevent it from falling down.
 - When connecting the unit's power cord to an AC outlet, use the AC outlet with current capacity allowable to the unit.
 - No rack-mounting screws are supplied with the unit. Separately prepare the appropriate screws for the rack.
- Keep the 9000 series amplifier over 10 cm (3.94") away from objects that may obstruct air flow to prevent the unit's internal temperature rise.

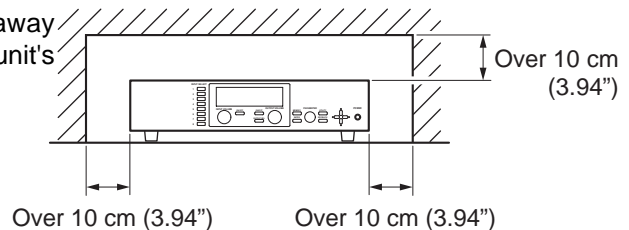

When the Unit is in Use

- Do not operate the unit for an extended period of time with the sound distorting. This is an indication of a malfunction, which in turn can cause heat to generate and result in a fire.
- Switch off the power, and unplug the power supply plug from the AC outlet for safety purposes when cleaning or leaving the unit unused for 10 days or more. Doing otherwise may cause a fire or electric shock.

An all-pole mains switch with a contact separation of at least 3 mm in each pole shall be incorporated in the electrical installation of the building.



The lightning flash with arrowhead symbol, within an equilateral triangle, is intended to alert the user to the presence of uninsulated "dangerous voltage" within the product's enclosure that may be of sufficient magnitude to constitute a risk of electric shock to persons.



ATTENTION

L'appareil ne doit pas être exposé aux éclaboussures ou écoulements et tous objets remplis de liquide, tels que vases, ne doivent pas être sur l'appareil.

3. GENERAL DESCRIPTION

TOA's 9000 series Amplifier is designed to be used in conjunction with optional modules and can be configured for up to 8 inputs and 8 outputs. Usable modules include the following 9000 series plug-in modules: D-001T and D-001R (2-channel input), T-001T (Audio output expansion), C-001T (Control I/O expansion), ZP-001T (Zone paging), AN-001T (Ambient noise sensor), and RC-001T (Remote controller interface), as well as 900 series input modules. The most appropriate modules can be selected depending on applications.

The 9000 series amplifier can be used as a mixer that is appropriate for speech or sound reinforcement applications. It is equipped with signal processing and control functions, permitting all parameters to be set at the amplifier.

Each input can also be set as a paging input, to which one of 3 priority levels can be assigned. The paging input takes precedence over other mixing inputs, thus allowing priority paging calls to go through to the designated outputs. Paging calls can be activated by triggers of various types. Multiple paging calls can be selectively used according to their priority levels. Thus, the 9000 series can effectively meet a room combining application.

Setting data of both mixing and paging functions can be stored inside the amplifier.

The 9000 series come with power amplifier, can perform 2-channel or stereo broadcast in stand-alone operation.

All settings that can be made at the unit can also be made on the PC using the supplied dedicated software.

[Compatibility of the firmware version and software version]

This instruction manual supports the 9000 Series amplifiers' firmware Ver. 2.00 or later and the PC Setting software Ver. 2.00 or later.

Some of the functions described in this manual do not work on the firmware and PC software versions earlier than Ver. 2.00. If you use the older version of the 9000M2, update the firmware and PC software versions to the latest ones. Also, be sure to back up the 9000M2's setting data using the PC Setting software before performing updates.

Notes

- While performing version update, make sure to prevent the power cable and communication cable from accidentally coming off.
- Once updated to firmware Ver. 2.00 or later, you cannot downgrade back to firmware Ver. 2.00 or earlier. The indication "INVALID VERSION" is displayed on the 9000 amplifier's front-mounted display (VFD) and PC's screen when attempting to perform downgrade. (Refer to the screen shot below.) The indication is displayed for a few seconds, then the 9000 amplifier restarts with the version remaining unchanged.

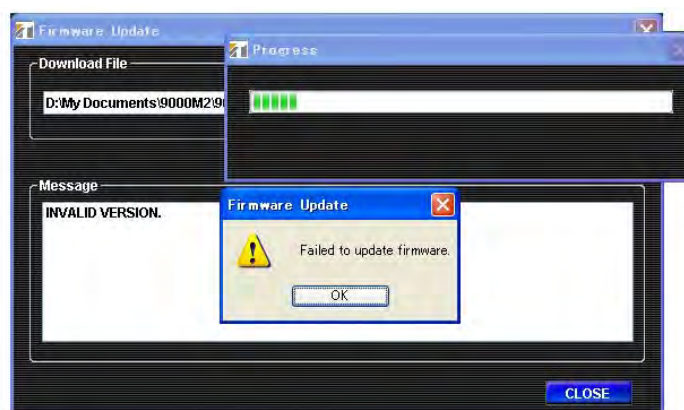

4. FEATURES

- Can be configured as a mixer or paging amplifier by settings, depending on application.
- Eight module slots enable audio input and output configuration ranging from 1 input and 1 output to 8 inputs and 8 outputs.
- All settings can be performed at the unit using the built-in vacuum fluorescent display (VFD), setting keys and Parameter setting knob on the front panel.
- Paging calls can be made from the designated outputs by setting the paging source, priority, and trigger even while the unit is being used as a mixer.
- Up to 32 mixing settings can be stored as Scene memory, which can be recalled by the unit or external connected equipment.
- Different paging calls can be selectively used depending on situations as two or more paging sources can be set and different priority levels can be assigned to them. Other functions allow paging calls to be activated with various types of triggers and up to 32 paging groups to be saved independently of scene memory.
- An RS-232C port permits remote control of the unit using an AMX^{*1} or Crestron^{*2} controller, or similar external equipment.
- With the use of the optional AN-001T Ambient Noise Sensor Input module and AN-9001 Ceiling Mount Microphone, the amplifier's output volume can be automatically adjusted in response to the change in ambient noise level.
- Using the optional RC-001T Remote Control Module in conjunction with the Remote control panels such as ZM-9011, ZM-9012, ZM-9013, or ZM-9014 permits operations including scene and sound source switchings, paging initiation, control output ON/OFF, and volume adjustment to be remotely controlled.
- The optional ZM-9001 Zone Manager adds 6 control inputs, while the optional ZM-9002 Zone Manager adds 4 control inputs and 1 volume control.
- A ducker function^{*3} permits paging calls to be made without interrupting BGM broadcasts. Besides, an auto-mixing function (ducker function^{*3} and NOM attenuation function^{*4}) automatically adjusts the output gain.

*1 AMX is a trademark of AMX Corporation.

*2 Crestron is a trademark of Crestron Electronics, Inc.

*3 The Ducker function automatically attenuates input signals with lower priority when two or more audio signals are simultaneously received.

*4 The NOM (Number of Open Microphones) attenuation function automatically adjusts the output channel gain depending on the number of open microphones.

5. INSTALLATION PRECAUTIONS

- Keep the 9000 series amplifier over 10 cm (3.94") away from objects that may obstruct air flow to prevent the unit's internal temperature rise.

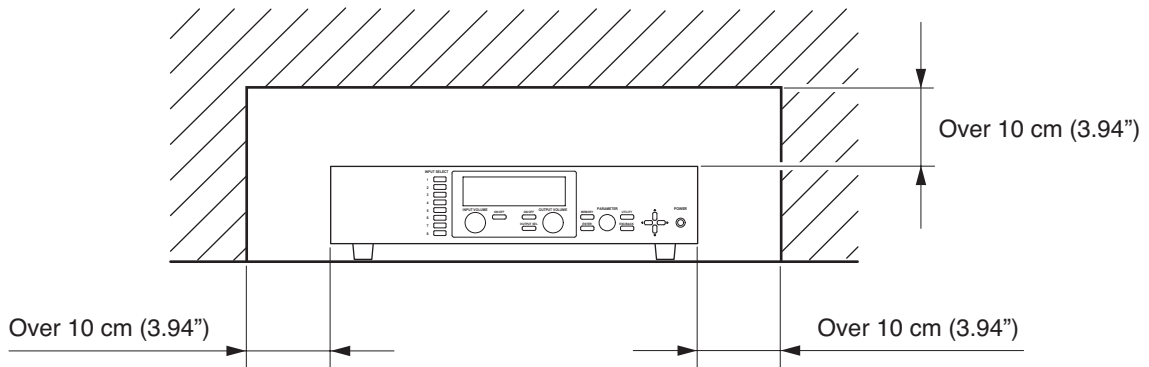

- When mounting the unit on an equipment rack
 - Use the supplied rack-mounting bracket. (For the bracket attachment, refer to [p. 121 "RACK MOUNTING BRACKET ATTACHMENT."](#))
 - Have the unit well-ventilated, and be sure to mount a 1U or more size perforated panel above and below the unit to prevent the unit's internal temperature rise.

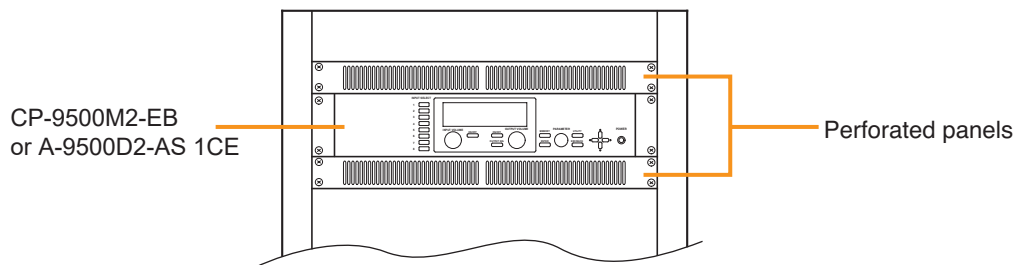

6. HANDLING PRECAUTIONS

- The supplied power supply cord is designed for exclusive use with this unit. Never use it with other equipment.
- Use the unit in locations where the temperature is between -10 and $+40^{\circ}\text{C}$ or 14 and 104°F (no condensation should be formed), and the humidity is less than 80%.
- The unit is a precision audio component. To prevent failure, avoid locations where it may be exposed to strong shocks or vibrations.
- To clean, be sure to first disconnect the power supply plug from the AC outlet, then wipe with a dry cloth. When extremely dirty, use a soft cloth dampened in neutral detergent. Never use benzene, thinner, alcohol or chemically-treated towels, which may damage the unit's finish.

7. NOMENCLATURE AND FUNCTIONS(EXAMPLE FOR CP-9500M2-EB)

7.1.CP-9500M2-EB Amplifier

[Front]

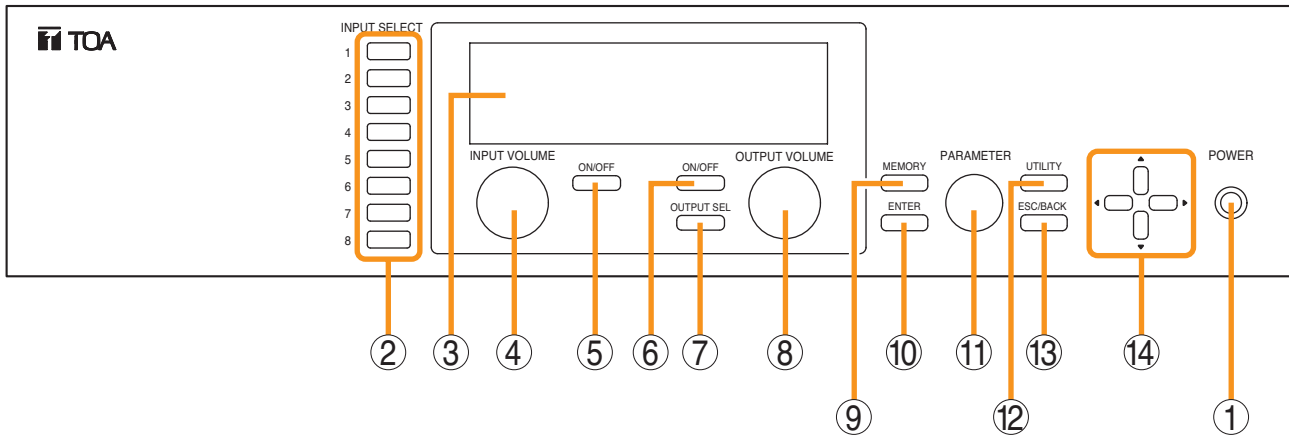

1. Power switch and Power indicator

Press this switch to turn on the power. The power indicator lights. To turn off the power, hold down the switch for at least 0.5 second.

Note

The power switch is a soft-switch, so the internal microcomputer is still operating even when the power switch is set to OFF.

2. Input channel selection keys

Select the input channel for which the volume is adjusted or parameter is set.

Pressing the key causes the corresponding red channel indicator to light on the vacuum fluorescent display (VFD).

3. Vacuum fluorescent display (VFD)

Displays the setting screen, input and output selection status, channel ON/OFF status, input and output level meter indication, and fader position.

The VFD enters the display saver mode if no key is operated for a fixed period of time.

(Refer to p. 13 "VFD on-screen indications.")

4. Input volume control

Adjusts the gain of the input channel selected with the input channel selection key (2).

5. Input channel ON/OFF key

Turns on or off the channel selected with the input channel selection key (2).

6. Output channel ON/OFF key

Turns on or off the channel selected with the output channel selection key (7).

7. Output channel selection key

Selects the output channel for which the volume is adjusted or parameter is set. The output channel indicators on the VFD light in sequence each time the key is pressed.

8. Output volume control

Adjusts the gain of the output channel selected with the output channel selection key (7).

9. Memory key

Used to save the current settings into a Scene memory or recall a saved Scene setting.

10. Enter key

Press this key when "OK ?" is displayed in the setting screen or when proceeding to the next screen.

11. Parameter setting knob

Rotate this knob to select the setting item or setting contents.

12. Utility menu key

Used to perform Utility setting.

13. Escape/Back key

Used to revert back to a previous screen when advanced with the Enter key during setting operation, or return to the screen on the upper hierarchy level.

14. Screen shift keys [▲ ▼ ◀ ▶]

Move the setting screen or setting item.

[VFD on-screen indications]

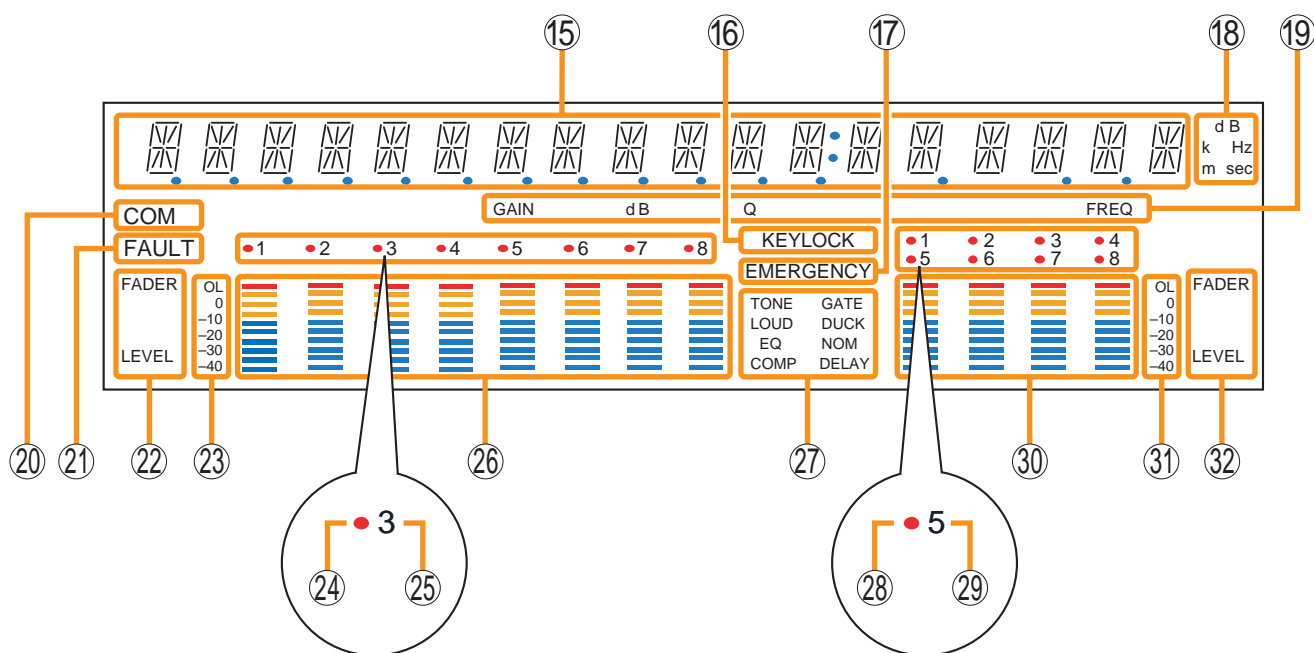

15. 14-Segment,18-digit alphanumeric display

Displays the corresponding setting screen or data when each function key is pressed. Parameters being edited flash.

16. Keylock indicator

Lights when the key lock function is enabled, and flashes while the key lock function is being edited.

17. Emergency indicator

Lights when the control input set for "Emergency mute" becomes active.

18. Unit indicator

Displays the unit of each parameter when it is set.

19. GAIN, dB, Q, FREQ indicators

Lights when the equalizer is adjusted.

20. COM indicator

Remains lit during communications via the RS-232C interface.

21. Fault indicator

Lights or flashes when the unit's failure or other abnormal conditions are detected. (Refer to p. 132 "ERROR INDICATIONS.")

22. Input meter status indicator

Indicates which the input level (LEVEL) or input fader position (FADER) is being displayed on the input meter (26).

Note

Input level is displayed only when the D-001T/R module is used.

23. Input level indication

Scale of levels (in dB) for the input meter.

24. Input channel selection indicator (red dot)

Lights when the corresponding input channel is selected, and flashes while parameters are being edited.

25. Input channel ON/OFF indicator (channel number)

The indicators for all channels normally light regardless of whether or not the channels can be selected by the input channel selection keys (2) or can be used (p. 134 "Remarks"), while they flash when turned off by the input channel ON/OFF key (5).

The indicators of unused channels can be set to be off in the Utility setting item.

26. Input meter

Indicates the signal level or input fader position of each input channel.

Which the meter is indicating is displayed on the input meter status indicator (22).

Notes

- The input meter is kept on even for the channel that is turned off or muted.
- Input level is displayed only when the D-001T/R module is used.

27. Effect indicator

Lights when effect is on, and flashes while the parameters are being edited.

28. Output channel selection indicator (red dot)

Lights when the corresponding output channel is selected, and flashes while parameters are being edited.

29. Output channel ON/OFF indicator (channel number)

Lights when the corresponding output is on (i.e. in operation mode), and flashes when off. The number of channels of which indicators light depends on the modules used.

30. Output meter

Indicates the signal level or output fader position of each output channel. Which the meter is indicating is displayed on the output meter status indicator (32).

Notes

- Even when the 9000 series's output channel 1 or 2 is turned off or muted, the output meter for these channels remains on.
- The output meters are not influenced by their output volume control settings.

31. Output level indication

Scale of levels (in dB) for the output meter.

32. Output meter status indicator

Indicates which the output level (LEVEL) or output fader position (FADER) is being displayed on the output meter (30).

Notes

- The VFD automatically enters the display saver mode and indicates "DISPLAY SAVER MODE. PRESS ANY KEY" scrolling sideways if no key is operated for 20 minutes. In this case, the VFD reverts to normal if any key is pressed. Be sure to press any key to make the VFD active before performing any operation.
- The VFD is a consumable item. Its brightness decreases by half after about 30000 hours of continuous lighting.

A built-in display saver mode that automatically dims the VFD light will extend the life of VFD.

[Changing the indicated channels on the LEVEL output meter]

The output meter indicates the signal levels of only a set of 4 channels: CH 1 – 4 (factory-preset) or CH 5 – 8. When the input or output gain setting screen is displayed, pressing the Up shift key alternately switches the level indication between CH 1 – 4 and CH 5 – 8.

The LEVEL indicator of the output meter status indicator flashes while the CH 5 – 8 are indicated, and stays lit while the CH 1 – 4 are indicated.

In the same manner, the output meter also changes in the Fader indication.

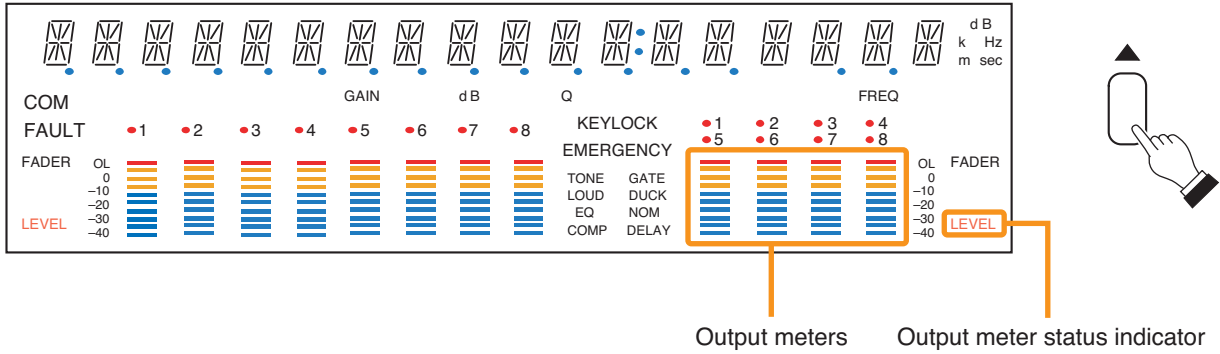

[Changing the input and output meter display status]

When the input or output gain setting screen is displayed, pressing the Down shift key alternately switches the input and output meter display status between the signal level and the fader position.

The LEVEL indicators on both input and output meters light when the signal levels are indicated, while the FADER indicators light when the fader positions are indicated.

When an input channel's gain setting screen is displayed, the meter display status can be switched between the signal level and fader position each time the input channel selection key of the channel being set is pressed.

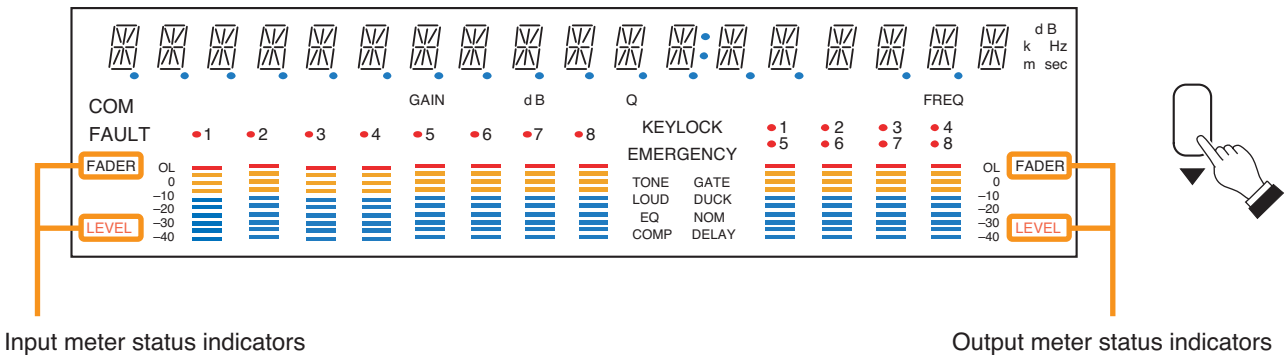

Note: The figure above is the VFD screen display when the input and output levels are indicated.

[Rear]

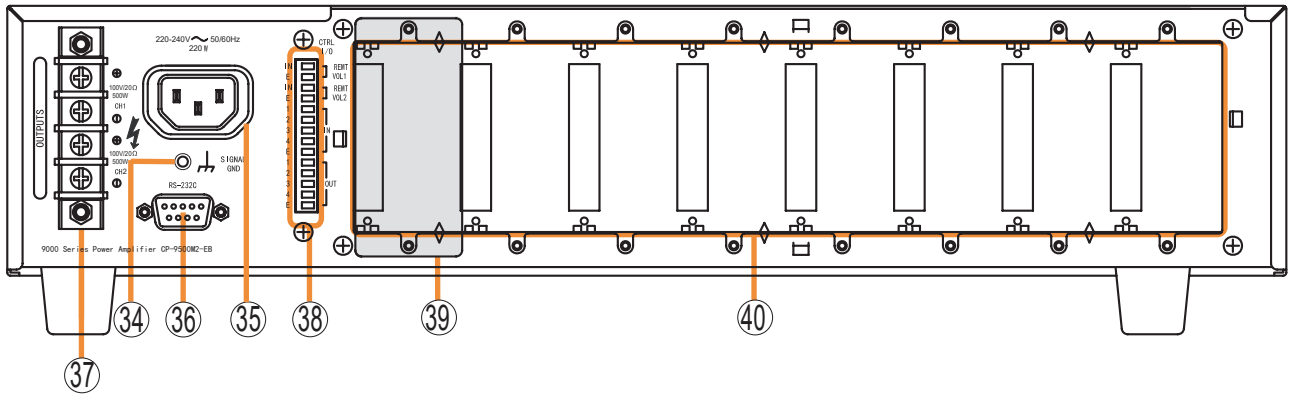

34. Functional earth terminal

Hum noise may be generated when external equipment is connected to the unit. Connecting this terminal to the functional earth terminal of the external equipment may reduce the hum noise.

Note: This terminal is not for protective earth.

35. AC inlet

Connect the supplied power cord.

36. RS-232C serial communication port

Connector for communications with a personal computer or control equipment.

37. Speaker output terminal

Connect speakers of which total impedance matches the amplifier's output impedance.

(Refer to [p.112 "Speaker Output Terminal Connections."](#))

38. Control-I/O connection terminal

Connect a 10 k Ω (linear taper) variable resistor or input the DC voltage of 0 to +10 V to the remote volume control terminals (REMT VOL 1 and 2) when remotely adjusting the volume.

To perform other remote control operation, connect the ZM-9001 or ZM-9002 Zone Manager.

Input and output terminals (IN and OUT) are used to change the unit's internal status or output internal status data to external equipment after having received various control signals.

39. Blank panel (accessory)

Attach the blank panels to open slots.

40. Module slots

900 Series or 9000 Series modules can be inserted into these slots.

(Refer to [p. 106 "MODULE INSTALLATION."](#))

7.2. Optional Modules

7.2.1. D-001T and D-001R (2-Channel Input Modules)

The D-001T and D-001R modules are designed for use with the 9000 series.

Up to 4 modules (8 channels in total) can be inserted into the amplifier.

Both modules can handle signals ranging from microphone level (–60 dB) to line level (–10 dB) in 9 input sensitivity levels. They have an internal digital signal processor that can process input signals.

The D-001T can supply phantom power (24 V).

The D-001T or D-001R is required to use a VOX (Voice Operated Exchange) function and input channel level meter.

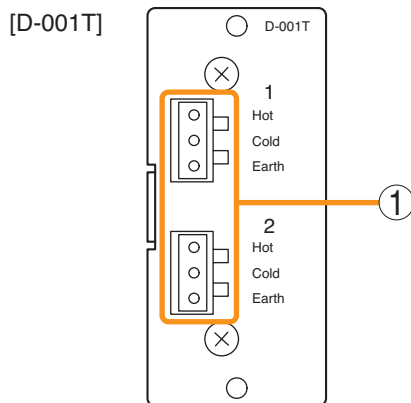

[D-001T]

1. Monaural input terminals [1, 2]

Electronically-balanced input terminals.

Type of connector: 3P removable terminal blocks

Input level: –60 dB to –10 dB selectable

Input impedance: 10 k Ω when the phantom power is OFF, and 3 k Ω when ON

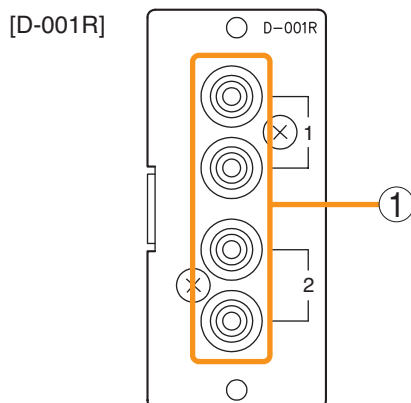

[D-001R]

1. Monaural input terminals [1, 2]

Unbalanced input terminals.

Type of connector: RCA jacks

Input level: –60 dB to –10 dB selectable

Input impedance: 10 k Ω

Two inputs of each channel are mixed.

7.2.2. T-001T (Audio Output Expansion Module)

The T-001T module is designed for use with the 9000 series and can expand 2 output channels per module.

Since the main unit has 2 fixed outputs, the audio output can be expanded to 8 channels by using a maximum of 3 modules (6 channels).

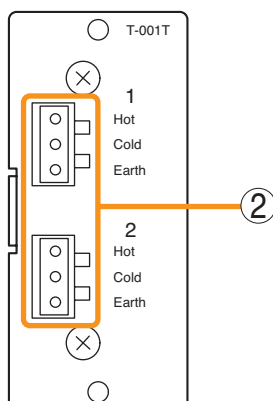

2. Monaural output terminals [1, 2]

Electronically-balanced 3P removable terminal blocks.

Output level: 0 dB

Output impedance: 600 Ω

For unbalanced connection, connect the unit's Hot and Earth terminals to the connected equipment's Signal and GND terminals, respectively. (Keep the unit's Cold terminal free.)

7.2.3. ZP-001T (Zone Paging Module)

The ZP-001T module is designed for use with the 9000 series and functions as an interface to connect the 9000 series to an analog PABX, allowing zone paging to be initiated from the PABX. Only one ZP-001T module can be used per 9000 series.

There are two operation modes: Ring signal and Paging port modes. Select one of the two modes when using this module.

The operation method differs depending on the set operation mode. (Refer to p. 46 "Making Zone Paging.")

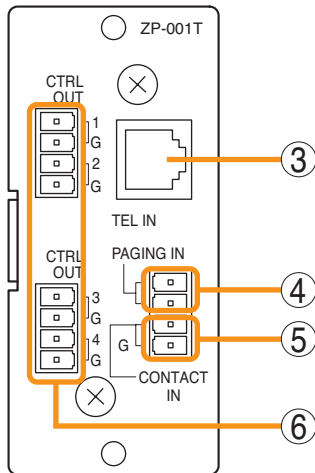

3. Telephone input terminal [TEL IN] (Modular jack)

Interface connector for an analog PABX.

Connect a PABX to this terminal when using the module in the ring signal mode.

4. Paging input terminal [PAGING IN]

4-pin removable terminal block, 2 pins are used for this input.

This terminal is used to connect a PABX in the paging port mode.

5. Control input terminal [CONTACT IN]

4-pin removable terminal block, 2 pins are used for this input.

Connect the control output from a PABX to this terminal.

6. Control output terminals [CTRL OUT 1 G, 2 G, 3 G, 4 G]

4-pin removable terminal blocks, control output terminals.

Note: These terminals are not used in the 9000 series amplifier.

[Requirements of the PABX to be connected to the ZP-001T]

- The PABX shall be compliant with TIA/EIA-464-B standard.
- Specifications or conditions required in each of the following modes shall be satisfied:

Note: The ZP-001T may malfunction if the connected PABX does not meet the above requirements.

(A) When using the module in the Paging port mode

- Connection: Line level paging port
- Signaling method: DTMF (The module cannot be operated with dial pulse.)
- Shall provide no-voltage make contact during paging calls.
- Insensitive to whether loop voltage exists or not, and whether polarity of the loop voltage is reversed or not when a line connection is established.

Note

If the PABX does not meet the above requirements, use the D-001T/R module and set the trigger to "VOX" (Voice Operated Exchange) to initiate paging. In this case, the paging output channel cannot be selected, which differs from the operation by the ZP-001T.

(B) When using the module in the Ring signal mode

- Connection: Analog two-wire extension line, loop start
- Signaling method: DTMF (The module cannot be operated with dial pulse.)
- Reorder tone: 120 IPM (impulses per minute) or less
- Loop voltage: 24 V DC or more (polarity insensitive), which should be supplied from the PABX.
- Insensitive to whether polarity of the loop voltage is reversed or not at a call from the PABX.*
- Loop voltage supply shall not be cut off from the beginning of a call to the reorder tone out.*
- The state of CPC (Calling Party Controlled) break or "Open Loop Disconnect" shall be reset at the PABX.*

* Note that there is no need to meet these requirements provided that the ZP-001T's control input terminals are kept closed. However, noise may be output if the line is physically disconnected during a paging call because the ZP-001T cannot recognize the line cutoff nor stop output for 30 seconds after paging initiation.

7.2.4. C-001T (Control I/O Expansion Module)

The C-001T module is designed for use with the 9000 series and can provide up to 8 channels each of input and output expansion.

Since the main unit has 4 fixed inputs and outputs each, the control input and output can be expanded to up to 12 channels each when the C-001T module is used.

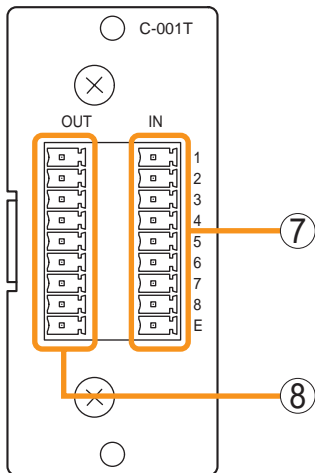

7. Control input terminal [IN 1, 2, 3, 4, 5, 6, 7, 8, E]

9-pin removable terminal block, 8-circuit control input terminal.

Individual input functions are assigned on the front panel setting screen of the main unit.

8. Control output terminal [OUT 1, 2, 3, 4, 5, 6, 7, 8, E]

9-pin removable terminal block, 8-circuit control output terminal.

Individual output functions are assigned on the front panel setting screen of the main unit.

7.2.5. AN-001T (Ambient Noise Sensor Input Module)

The AN-001T module is designed for use with the 9000 series and automatically adjusts the amplifier's output volume in response to the change in ambient noise level.

Maximum 2 AN-001T modules (4 channels in total) can be used per 9000 series.

It can handle signals from microphone level (−60 dB) to line level (−10 dB) by controlling the gain in 9 steps.

Phantom power (+24 V) can be supplied to a condenser microphone.

The AN-001T's inputs are for detecting ambient noise level and cannot be used as normal audio inputs.

Ambient noise fed to the inputs can be monitored when the monitor function is set to ON in the Input setting flow.

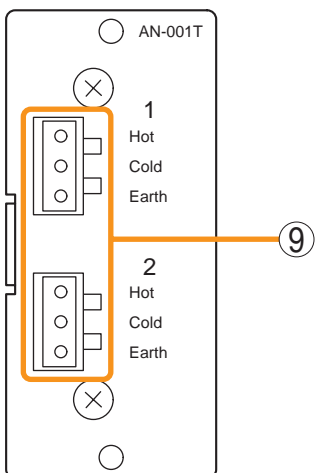

9. Monaural input terminals [1, 2]

Electronically-balanced 3P removable terminal blocks.

Input level: −60 dB to −10 dB selectable.

Input impedance is 10 kΩ when the phantom power is OFF, and 3 kΩ when ON.

7.2.6. RC-001T (Remote Control Module)

The RC-001T is an interface module to connect between the 9000 series and the ZM-9011, ZM-9012, ZM-9013, or ZM-9014 Remote Control Panel of data communication type. It allows the control panels to perform paging activation, scene memory change, and input/output volume control.

Up to 16 control panels can be connected to the RC-001T.

Power for the connected control panels is supplied from the AC adapters connected to the RC-001T. One AC adapter is needed every 8 control panels.

The maximum communication cable length between the RC-001T and control panels is max. 800 m (875 yd) in total.

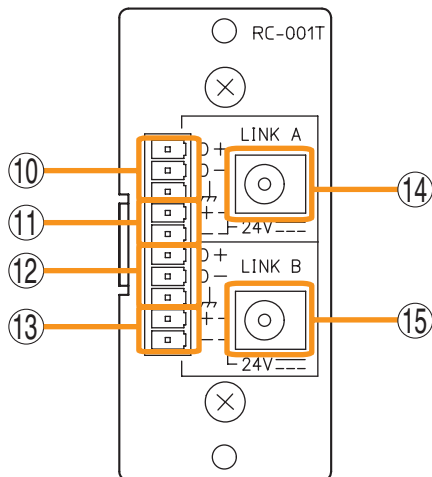

10. Data line connection terminals for Link A

Connect the communication line from up to 8 control panels. Note that the communication line has polarities.

11. 24 V DC output terminals for Link A

Supply 24 V DC power to the control panels.

12. Data line connection terminals for Link B

Connect the communication line from up to 8 control panels. Note that the communication line has polarities.

13. 24 V DC output terminals for Link B

Supply 24 V DC power to the control panels.

14. AC adapter input terminal for Link A

Connects the AC adapter for supplying DC power to the control panels of LINK A.

15. AC adapter input terminal for Link B

Connects the AC adapter for supplying DC power to the control panels of LINK B.

7.3. Optional Accessories

7.3.1. AN-9001 (Ceiling Mount Microphone)

The AN-9001 is designed to be mounted in a wall or ceiling with the use of a 1-gang electrical box. It is used in conjunction with the AN-001T Ambient Noise Sensor Input module in the 9000 series.

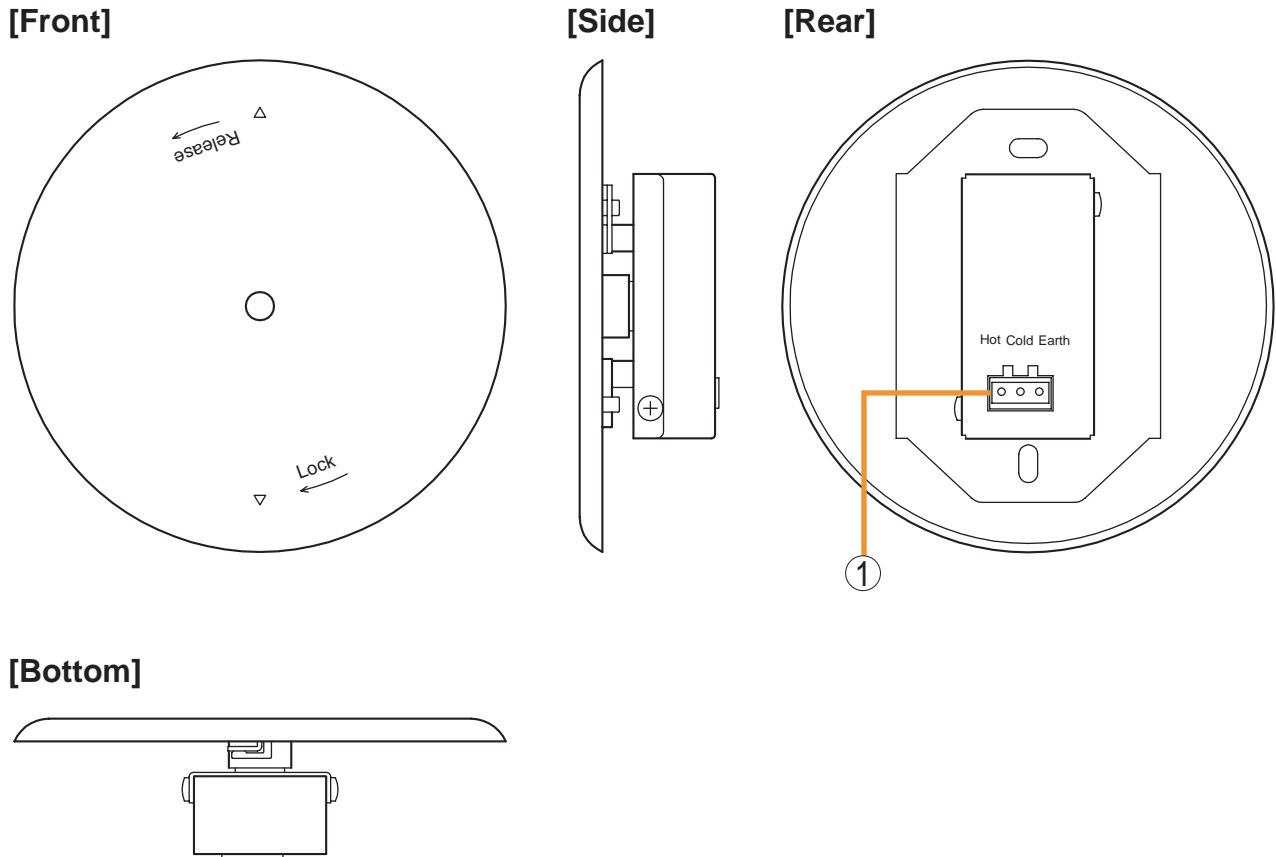

1. Microphone output terminal [Hot, Cold, Earth]

Electronically-balanced 3P removable terminal block.

Sensitivity: -5 dB (1 kHz, 0 dB=1 V/Pa)

Output impedance: 200 Ω

Note

In designing the layout of the AN-9001, pay particular attention to the following points so that the AN-9001 and AN-001T in combination can function effectively.

- Position the AN-9001 fully away from the speaker to be used for zone announcement. Doing otherwise may cause the AN-9001 to detect the speaker sound as noise, failing to keep the optimum sound level.
- Do not position the AN-9001 near the equipment that constantly generates loud noise. If positioned, the AN-9001 will respond to such loud noise, failing to respond to the change in ambient noise level.

7.3.2. ZM-9001 (Zone Manager)

The ZM-9001 adds 6 control inputs and can be mounted in a 1-gang electrical box.

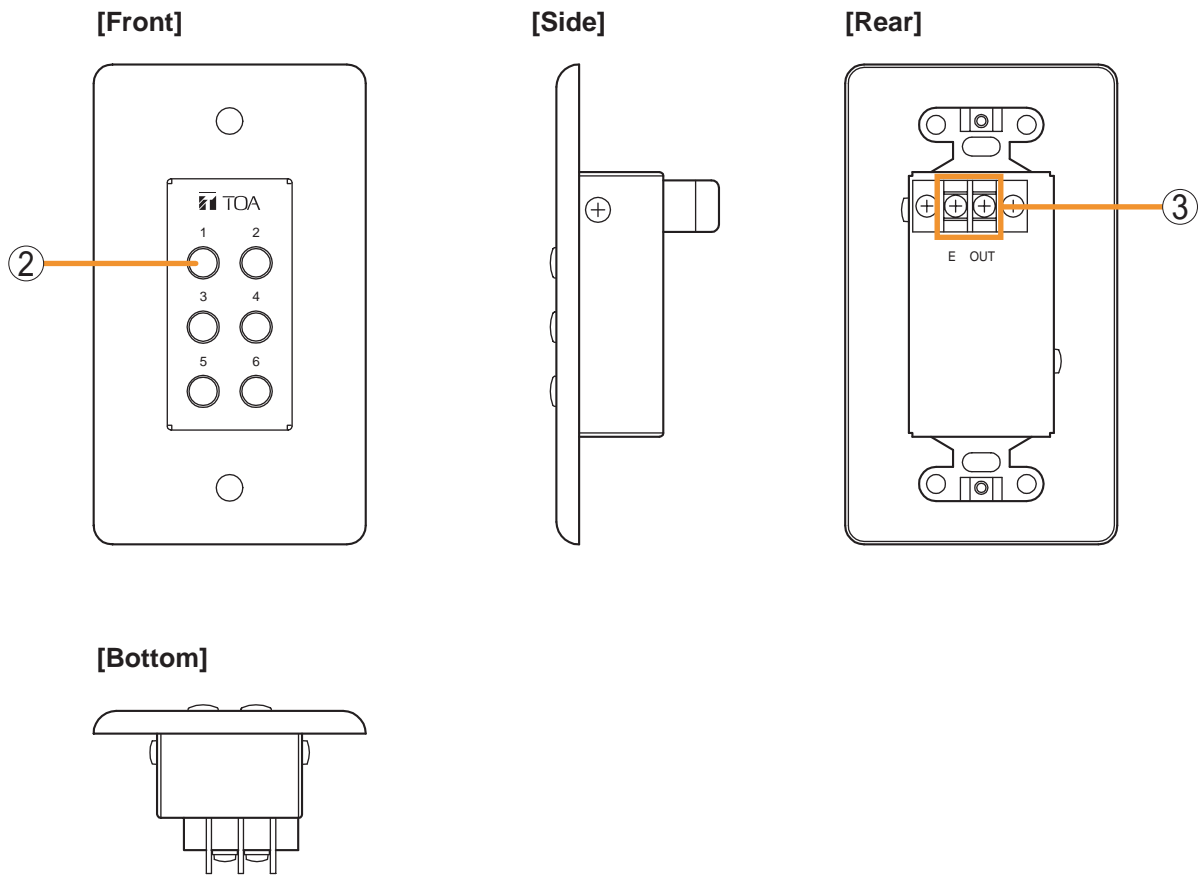

2. Control buttons [1 – 6]

Activate the function assigned to them when pressed.

3. Control output terminal [E, OUT]

Connect this terminal to the 9000 series REMT VOL terminal.

Use a shielded cable with 50 Ω or less line resistance (per line) for this connection.

Avoid installation of this cable and power cables in the same conduit. Separate piping.

7.3.3. ZM-9002 (Zone Manager)

The ZM-9002 adds 4 control inputs and 1 volume control, and can be mounted in a 1-gang electrical box.

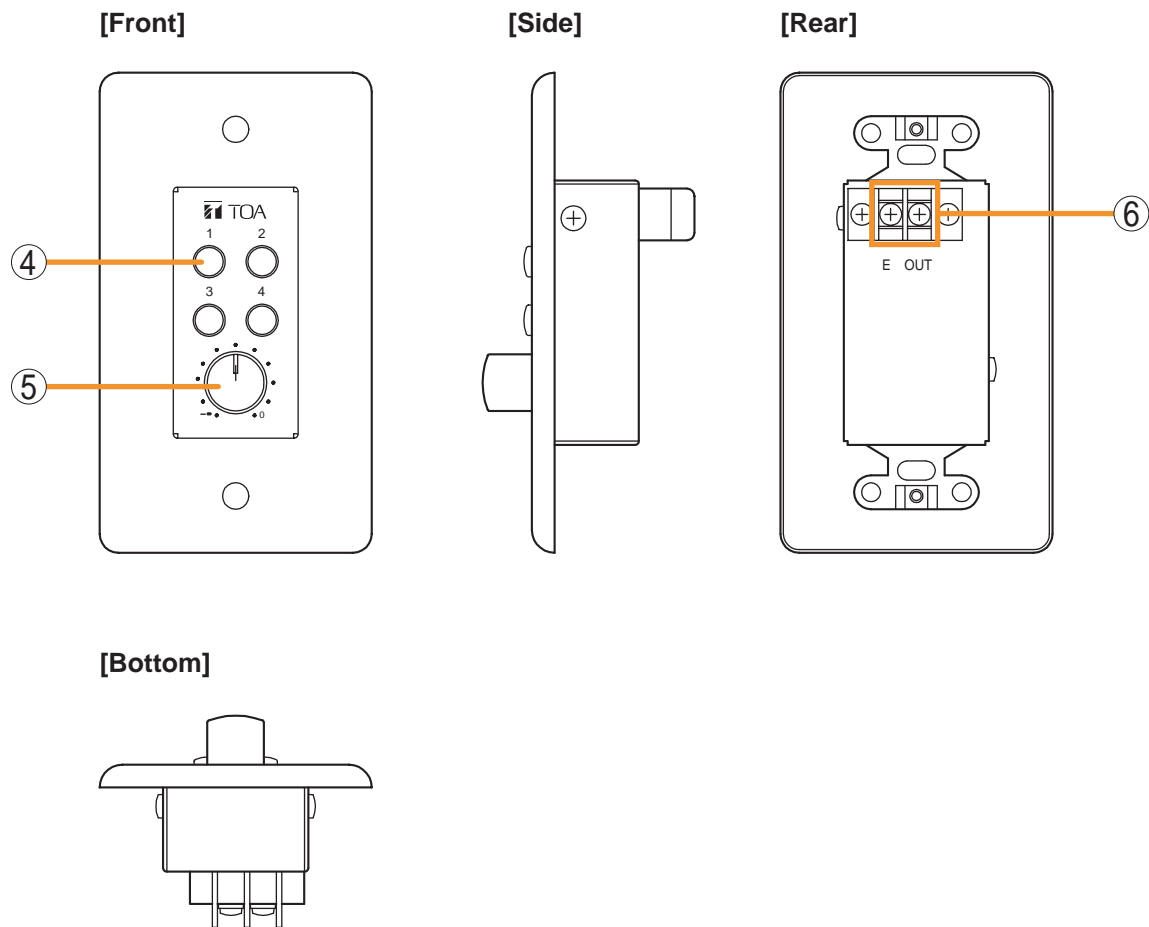

4. Control buttons [1 – 4]

Activate the function assigned to them when pressed.

5. Volume control

Adjusts the volume on the assigned input or output channel.

6. Control output terminal [E, OUT]

Connect this terminal to the 9000 series REMT VOL terminal.

Use a shielded cable with 50 Ω or less line resistance (per line) for this connection.

Avoid installation of this cable and power cables in the same conduit. Separate piping.

7.3.4. ZM-9003 (Zone Manager)

The ZM-9003 is a remote control switch panel with 4 control selection buttons and 2 control buttons. Connecting it to the 9000 series's control input terminal permits various controls such as BGM source selection and the sound volume adjustment.

It can be mounted in an American standard 2-gang electrical box in a wall.

[Front]

[Side]

[Rear]

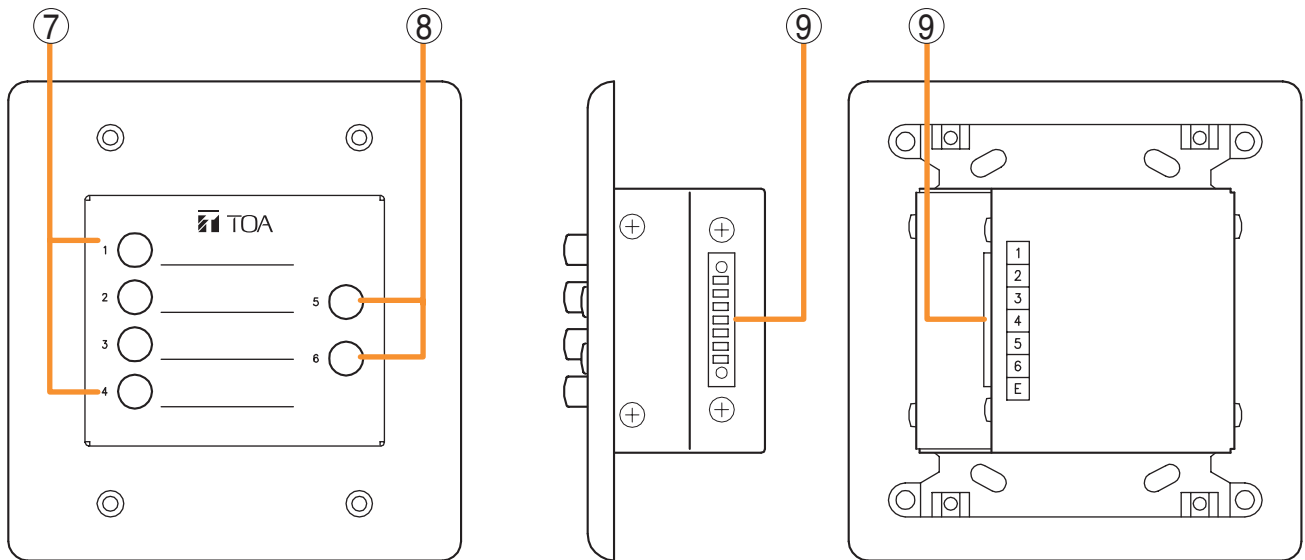

7. Control selection buttons (Interlocking selection switches) [1 – 4]

Activate the function assigned to them when pressed.

8. Control buttons (Momentary switches) [5, 6]

Activate the function assigned to them when pressed.

9. Control output terminal [1 – 6, E]

Connect this terminal to the 9000 series's control input terminal.

Use a cable with 250 Ω or less line resistance (per line) for this connection.

Avoid installation of this cable and power cables in the same conduit. Separate piping.

7.3.5. ZM-9011 (Remote Control Panel)

Designed to be connected to the RC-001T, the ZM-9011 is equipped with 4 buttons to perform various controls.

The in-use indicators turn on or off synchronizing with the amplifier operation through data communications between the ZM-9011 and the RC-001T.

It can be mounted in an American standard 1-gang electrical box.

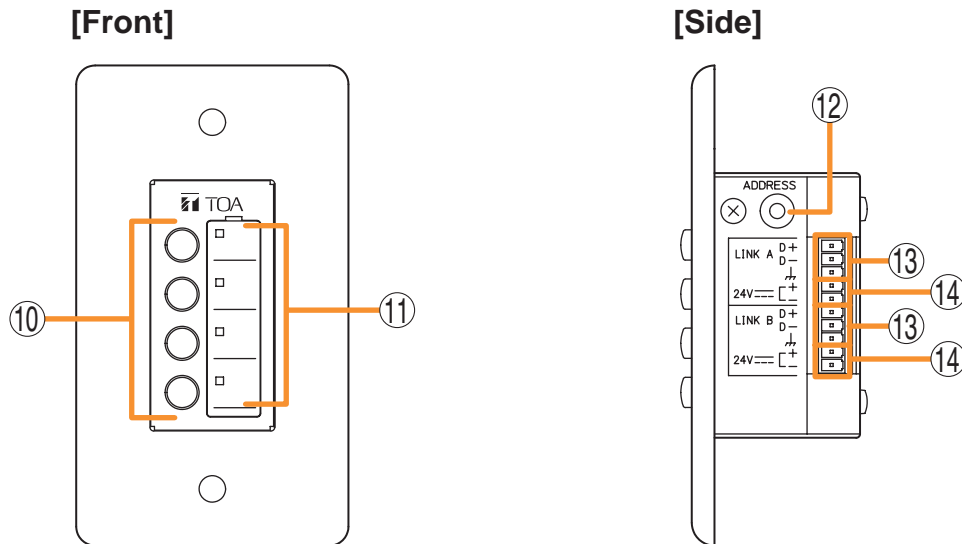

10. Control buttons

Activate the function assigned to them when pressed.

Functions to be assigned to these buttons are paging ON/OFF, cross point ON/OFF, scene switching, and control output.

11. In-use indicators

Light when the function assigned to the button pressed is activated.

It goes off automatically after the button operation if the function in operation is activated by higher priority equipment or reset by other equipment.

12. Address selector [0 – F]

Sets the ZM-9011 address.

Be sure to set the different address among other remote control panels.

Addresses are arranged numerically (0 – 9), and alphabetically (A – F) in this order.

13. Data terminals [LINK A/B D+, D-]

Connect the communication line to the RC-001T.

As the communication line has polarities, match both polarities of the ZM-9011 and the RC-001T when connected.

Each 2 identical terminals is provided, and the identical terminals are internally connected to one another. Either set of terminals can be used for connection to other controller.

14. 24 V DC input terminals [24 V +, -]

Connect the DC power cable from the RC-001T.

Each 2 identical terminals is provided, and the identical terminals are internally connected to one another. Either set of terminals can be used for connection to other controller.

7.3.6. ZM-9012 (Remote Control Panel)

Designed to be connected to the RC-001T, the ZM-9012 is equipped with a volume control knob to perform the volume level setting on the set input or output channel.

The indicators show the volume level set by the volume control knob, that is the volume control knob position. It can be mounted in an American standard 1-gang electrical box.

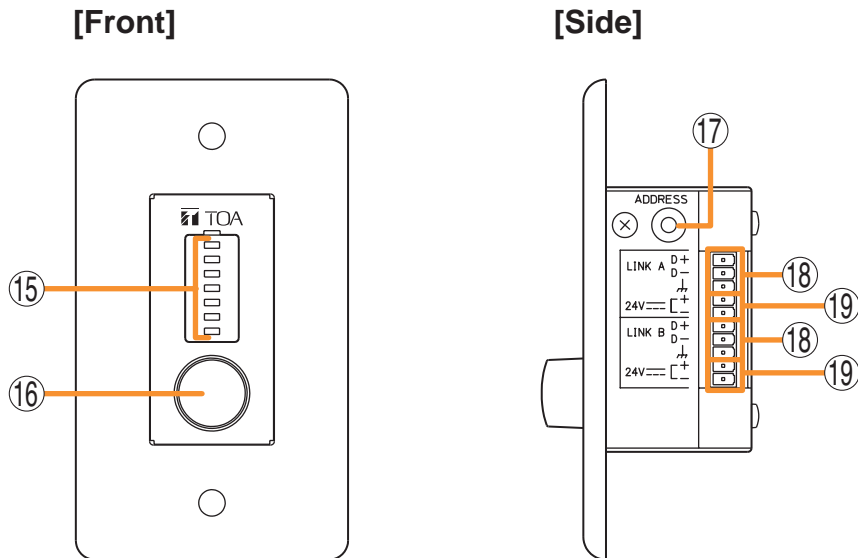

15. Set volume level indicators

Indicate the volume level set by the volume control knob (16). The set levels are shown by 7-point LED indicators, each of which shows -30 dB, -20 dB, -10 dB, -5 dB, 0 dB, +5 dB, and +10 dB from the bottom.

16. Volume control

Adjusts the volume level of input or output channel.

17. Address selector [0 – F]

Sets the ZM-9012 address.

Be sure to set the different address among other remote control panels.

Addresses are arranged numerically (0 – 9), and alphabetically (A – F) in this order.

18. Data terminals [LINK A/B D+, D-]

Connect the communication line to the RC-001T.

As the communication line has polarities, match both polarities of the ZM-9012 and the RC-001T when connected.

Each 2 identical terminals is provided, and the identical terminals are internally connected to one another. Either set of terminals can be used for connection to other controller.

19. 24 V DC input terminals [24 V +, -]

Connect the DC power cable from the RC-001T.

Each 2 identical terminals is provided, and the identical terminals are internally connected to one another. Either set of terminals can be used for connection to other controller.

7.3.7. ZM-9013 (Remote Control Panel)

Designed to be connected to the RC-001T, the ZM-9013 is equipped with 8 buttons to perform various controls.

The in-use indicators turn on or off synchronizing with the amplifier operation through data communications between the ZM-9013 and the RC-001T.

It can be mounted in an American standard 2-gang electrical box.

[Front]

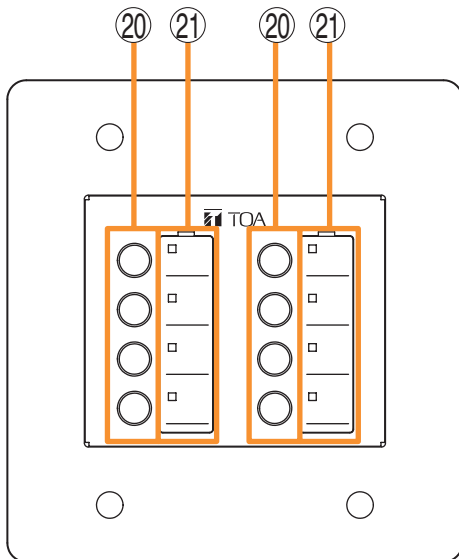

[Side]

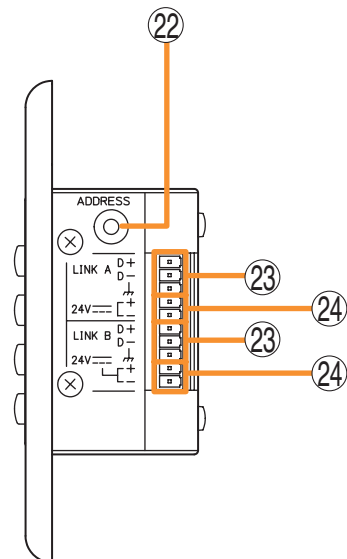

20. Control buttons

Activate the function assigned to them when pressed.

Functions to be assigned to these buttons are paging ON/OFF, cross point ON/OFF, scene switching, and control output.

21. In-use indicators

Light when the function assigned to the button pressed is activated.

It goes off automatically after the button operation if the function in operation is activated by higher priority equipment or reset by other equipment.

22. Address selector [0 – F]

Sets the ZM-9013 address.

Be sure to set the different address among other remote control panels.

Addresses are arranged numerically (0 – 9), and alphabetically (A – F) in this order.

23. Data terminals [LINK A/B D+, D-]

Connect the communication line to the RC-001T.

As the communication line has polarities, match both polarities of the ZM-9013 and the RC-001T when connected.

Each 2 identical terminals is provided, and the identical terminals are internally connected to one another. Either set of terminals can be used for connection to other controller.

24. 24 V DC input terminals [24 V +, -]

Connect the DC power cable from the RC-001T.

Each 2 identical terminals is provided, and the identical terminals are internally connected to one another. Either set of terminals can be used for connection to other controller.

7.3.8. ZM-9014 (Remote Control Panel)

Designed to be connected to the RC-001T, the ZM-9014 is equipped with 4 buttons to perform various controls and a volume control knob to perform the volume level setting on the set input or output channel. The indicators show the volume level for a channel set by the volume control knob, that is the volume control knob position.

It can be mounted in an American standard 2-gang electrical box.

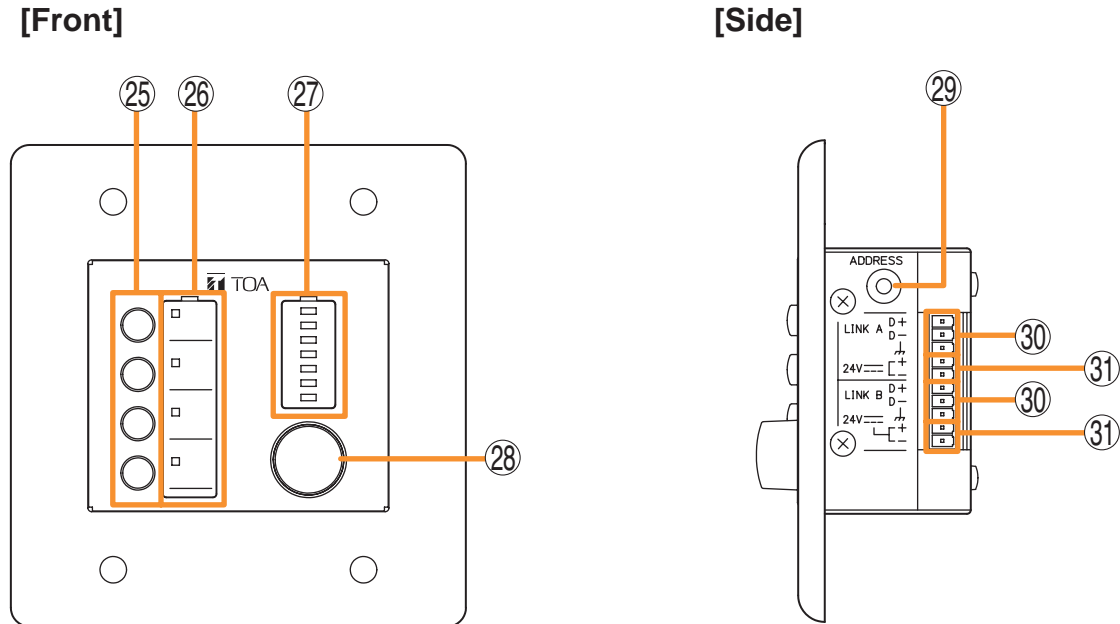

25. Control buttons

Activate the function assigned to them when pressed.

26. In-use indicators

Light when the function assigned to the button pressed is activated.

It goes off automatically after the button operation if the function in operation is activated by higher priority equipment or reset by other equipment.

27. Set volume level indicators

Indicate the volume level set by the volume control knob (28). The set levels are shown by 7-point LED indicators, each of which shows -30 dB, -20 dB, -10 dB, -5 dB, 0 dB, +5 dB, and +10 dB from the bottom.

28. Volume control

Adjusts the volume level of input or output channel.

29. Address selector [0 – F]

Sets the ZM-9014 address.

Be sure to set the different address among other remote control panels.

Addresses are arranged numerically (0 – 9), and alphabetically (A – F) in this order.

30. Data terminals [LINK A/B D+, D-]

Connect the communication line to the RC-001T.

As the communication line has polarities, match both polarities of the ZM-9014 and the RC-001T when connected.

Each 2 identical terminals is provided, and the identical terminals are internally connected to one another. Either set of terminals can be used for connection to other controller.

31. 24 V DC input terminals [24 V +, -]

Connect the DC power cable from the RC-001T.

Each 2 identical terminals is provided, and the identical terminals are internally connected to one another. Either set of terminals can be used for connection to other controller.

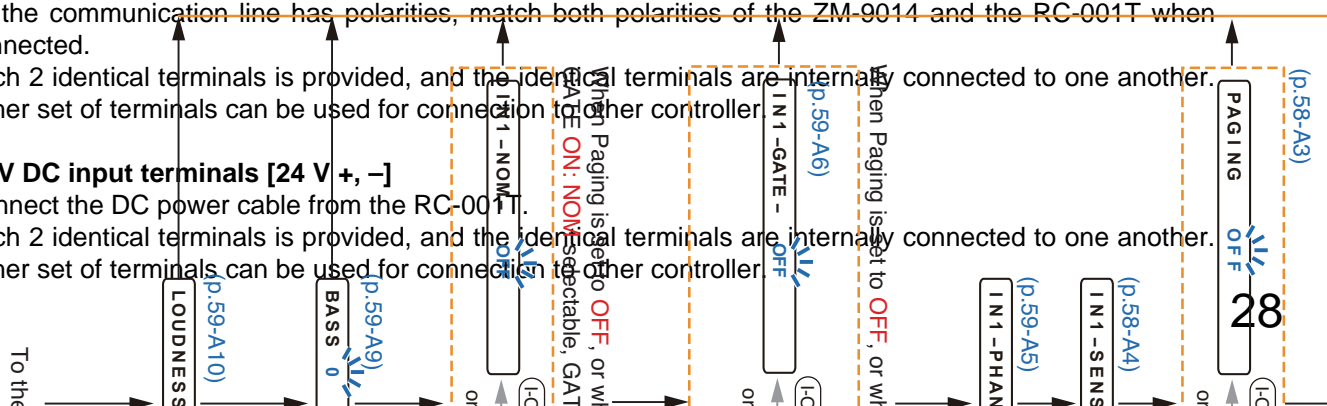

The lighting mode of the operation indicator differs depending on the function assigned to the Function button. When a communication error occurs between these remote control panels and the RC-001T module, the lighting mode differs from that in the normal state regardless of the function assigned to the button. The respective lighting modes are as follows.

[When the paging function is assigned to the Function button]

The indicator lights when the paging is activated by pressing the Function button. In this event, it flashes if paging call cannot be made because the higher-priority broadcast is in progress, and switches to steady-on once paging call access is enabled after the higher-priority broadcast completion.

- At the time of paging activation (When no priority broadcast is made)

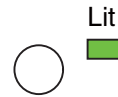

- (When priority broadcast is in progress)



- At the time of paging termination

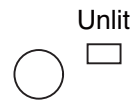

The indicator goes off when the paging call is completed by pressing the button again.

[When the cross point ON/OFF function is assigned to the Function button]

The indicator lights when the cross point function is enabled by pressing the Function button, and goes off when turned OFF by pressing the button again.

- (When set to ON)

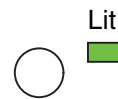

- (When set to OFF)

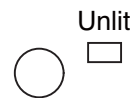

[When the scene recall function is assigned to the Function button]

The indicator lights when the preset scene is recalled by pressing the Function button, and goes off when switched over to other scene from other devices.

- (When the scene is recalled)



- (When other scene is recalled from other devices)

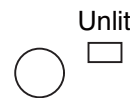

[When the contact control output function is assigned to the Function button]

The indicator lights when the set contact control output is turned ON by pressing the Function button. When the button operation is set to momentary type, the output turns on and also the indicator lights as long as the button is pressed. When the button operation is set to alternate type, the output alternates between ON and OFF each time the button is pressed and the indicator cycles between ON (lit) and OFF (unlit) as well.

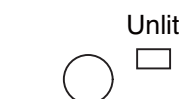

[When a communication error occurs]

The operation indicator goes off. When the Function button is pressed, the indicator lights briefly, then goes off.

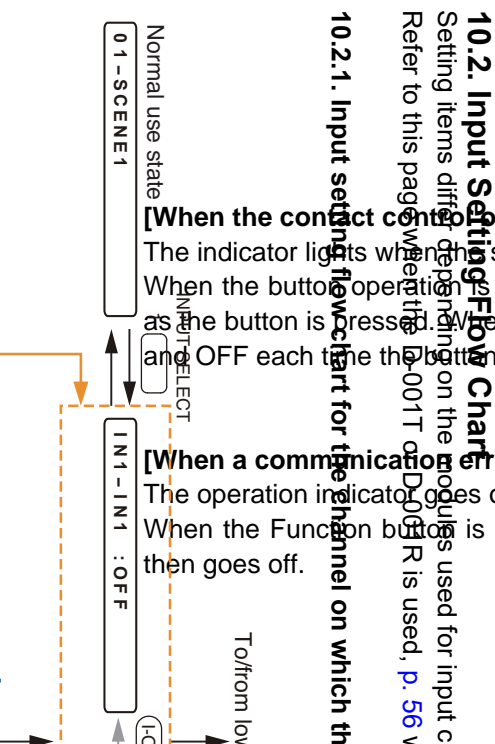

7.3.9. SS-9001 (Speaker Selector)

The SS-9001 selectively distributes each of 2 inputs to the same 4 output zones.

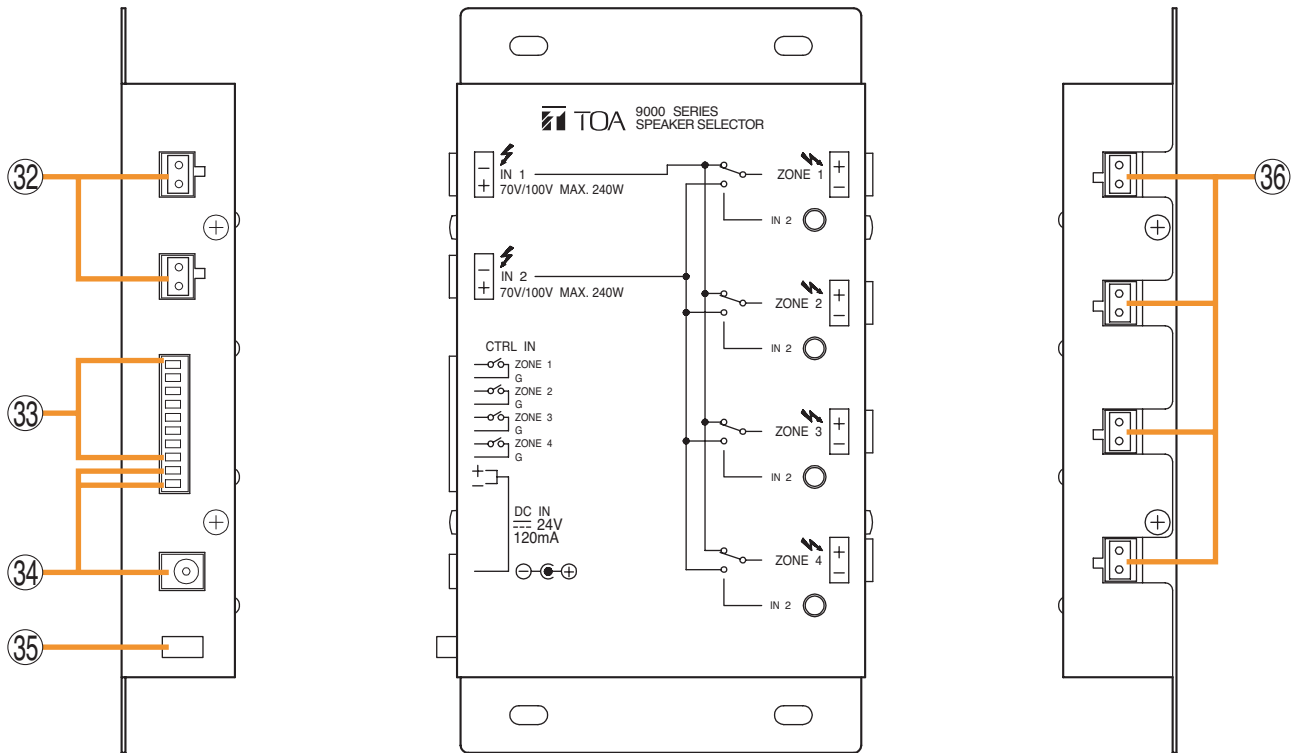

32. Speaker input terminals [IN 1, IN 2]

2-pin removable terminal blocks.

Connect the speaker output (high impedance line, up to 240 W) from the power amplifier to each terminal. Short the IN 2 terminal's pins when only the IN 1 terminal is used.

33. Control input terminal [CTRL IN]

8 pins in the 10-pin removable terminal block.

This terminal can also receive control signals from the control output terminals of the 9000 series Amplifier or C-001T Control I/O Expansion Module.

34. DC power input terminals [DC IN]

Requires the power input of 24 V DC.

DC input terminal or 2 pins in the 10-pin removable terminal block.

Connect the power source that can supply 200 mA or more to this terminal.

The optional AD-246 AC Adapter can be used for the power supply.

35. Cord clamp

Fixes the AC adapter's power cord. (P. 119 "Power Source Connections to the SS-9001")

36. Speaker output terminals [ZONE 1/2/3/4]

2-pin removable terminal blocks.

Connect speakers to each terminal, which is capable of delivering 240 W output on a line.

8. OPERATION OUTLINE

The unit can be used as a mixer amplifier or a paging amplifier depending on settings. The operation outline in each application is described below.

8.1. Using as a Mixer Amplifier

The ideal system for speech reinforcement applications in hotel meeting rooms, churches, and conference rooms and for sound reinforcement applications can be built.

The unit functions as a mixer amplifier to mix each input and provide audio signals at each output after audio signal processing necessary for sound systems.

Sound adjustments tailored to environments or situations of use can be stored as up to 32 scene memories, which can be recalled.

Other feature includes the gate function* and NOM attenuation function* that automatically adjust an input gain.

Using these functions permits the volume levels to be controlled depending on the situation where simultaneously broadcasting audio signals of multiple sound sources in the same space, for example, in a ballroom or meeting room.

* Refer to p. 40, "Glossary."

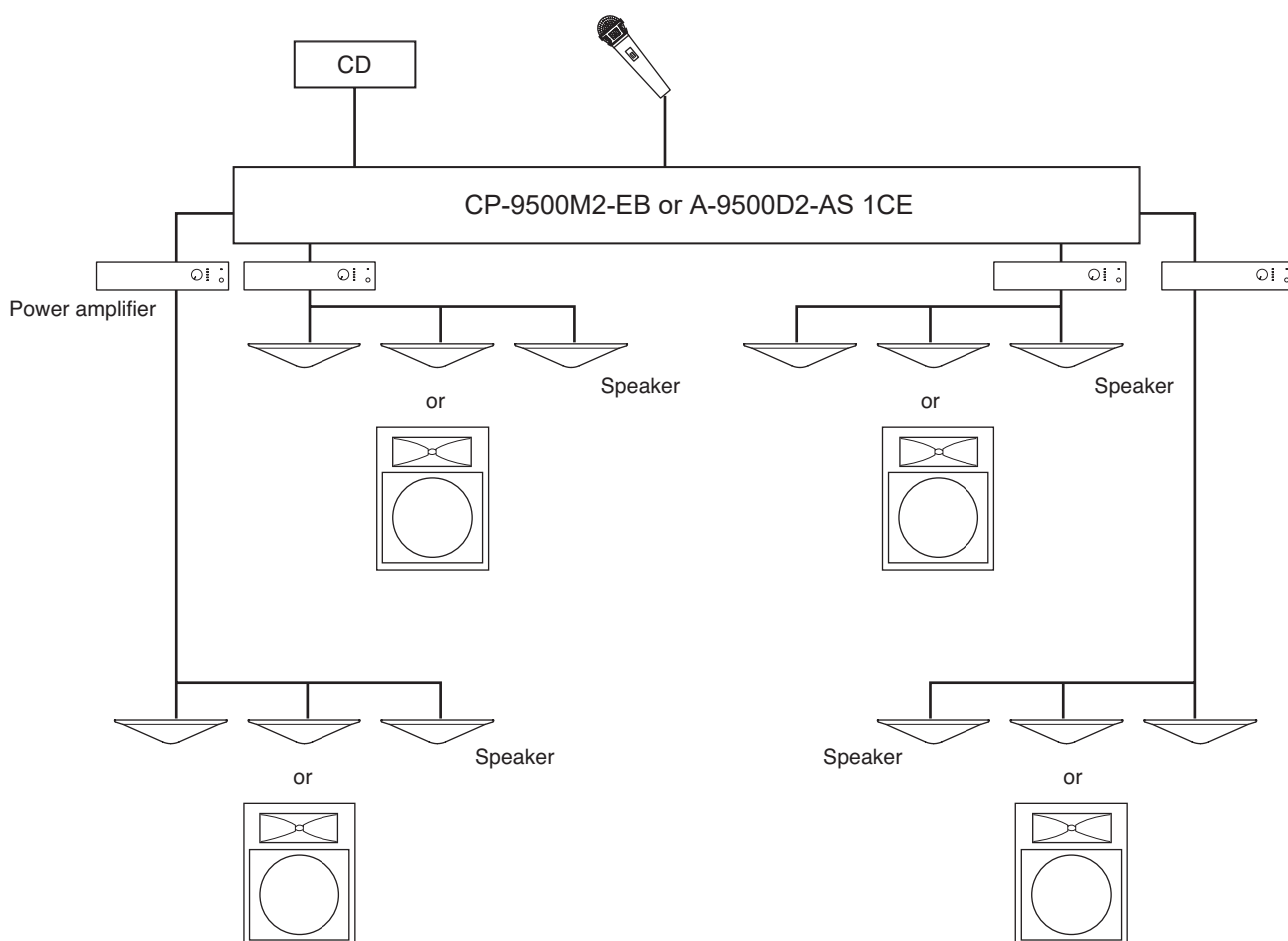

In this system, the remote control panel can be used to switch BGM sources.

The remote control panel is required to be set as follows using the PC setting software. For details, refer to the separate software instruction manual.

- Source selection mode: Exclusive mode
- Function assigned to the front-mounted button: Change cross point
- Assigned value for the button: Cross points for BGM source input and output channels

Making the above settings for two or more buttons enables these buttons to perform BGM selection.

8.2. Using as a Paging Amplifier

Allows input channels to have priority levels and the paging calls using these inputs to interrupt broadcasts being made through mixing inputs.

To enable paging calls, paging settings must be performed in addition to the input/output settings. For the paging output destination, group maximum 8 output channels to make up maximum 32 paging groups. Paging calls are output to each zone by activating paging.

Two or more paging sources, each having one of 3 priority levels, can be set.

The higher-priority paging takes precedence over the lower-priority paging call currently being made.

Paging calls can be made not only from a conventional microphone but through PBX (extension). For the paging setting, refer to [p. 54, "Input Setting Flow Chart."](#)

Note

Changing a scene or the setting data during paging causes the ongoing paging call to break.

So, do not make these changes during paging calls.

[Paging system outline]

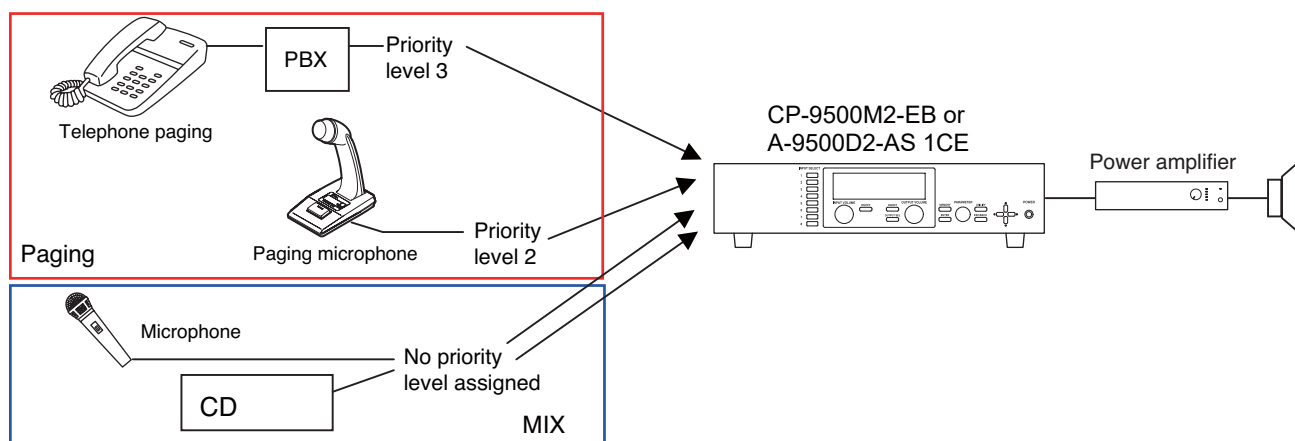

8.2.1. Paging using the D-001T, D-001R, or 900 series module

When using the D-001T, D-001R, or 900 series module as paging sound source, set the Paging ON/OFF setting ([p. 58](#)) for each input to ON. This will enable the priority level and paging group settings.

When using two or more paging sound sources, priority level can be set. For example, the following system can be configured in a supermarket, comprising sales area and backroom area. In the sales area, BGM is normally broadcast and announcement is made using a paging microphone. Also, it is so designed that emergency broadcasts and paging calls can be made to the whole area using a different paging microphone.

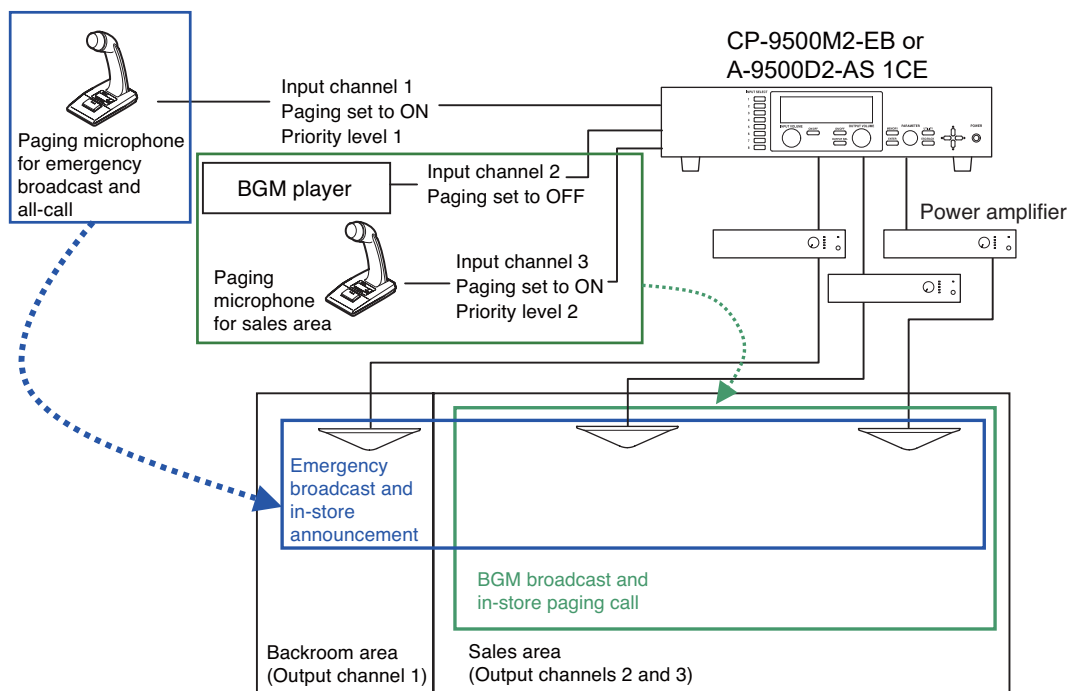

[Operation at normal broadcasts]

Normally BGM is broadcast (Input channel 2) in the sales area. When initiating paging with a paging microphone for sales area (Input channel 3), the paging call goes through, causing BGM volume level to decrease.

[Operation at emergency broadcasts]

When initiating paging with a paging microphone for emergency broadcast (Input channel 1), the paging call goes through to the whole area, causing BGM broadcast and in-store paging announcement currently being made to decrease.

If the emergency broadcast is being made, paging cannot be initiated using a paging microphone for sales area because it is connected to the input with lower priority level.

[Paging setting example]

Paging settings require to determine which input is to be sent to which output, and the trigger source to activate the paging calls in addition to the priority level settings.

In this example, set the paging microphone of Input channel 1 so that it is routed to Output channels 1, 2, and 3 (whole area). Likewise, set the paging microphone of Input channel 3 so that it is routed to Output channels 2 and 3 (sales area).

Set the paging trigger to "VOX," control terminals ("C-IN1 - 4" or "C-IN1 - 12" when the C-001T is used), front-mounted buttons on the ZM-9011, ZM-9013, or ZM-9014, or front-mounted buttons on the ZM-9001 or ZM-9002 (Busy input must be assigned to C-IN additionally).

In addition, telephone paging with the use of the ZP-001T can be made.

(For details of paging settings, refer to p. 46.)

8.2.2. Paging using the ZP-001T module

The ZP-001T's input is used as a paging input.

When making paging calls with the use of the ZP-001T, 3 operation modes are made available depending on the setting.

- AUTO: Automatically selects a single preprogrammed paging group when incoming call is received. There is no need to select a paging zone.
- MANUAL: Makes a paging call to the designated output with the telephone key operation (#1 - #8).
- GROUP: Selects one of 8 groups with the telephone key operation (#1 - #8). Group settings must be performed in advance.

[Telephone paging in AUTO mode]

In AUTO mode, when telephone paging is initiated, the paging call is made to the designated zones without the need to select them. This mode is convenient when always making paging calls to the whole zone or always to the preset zone(s).

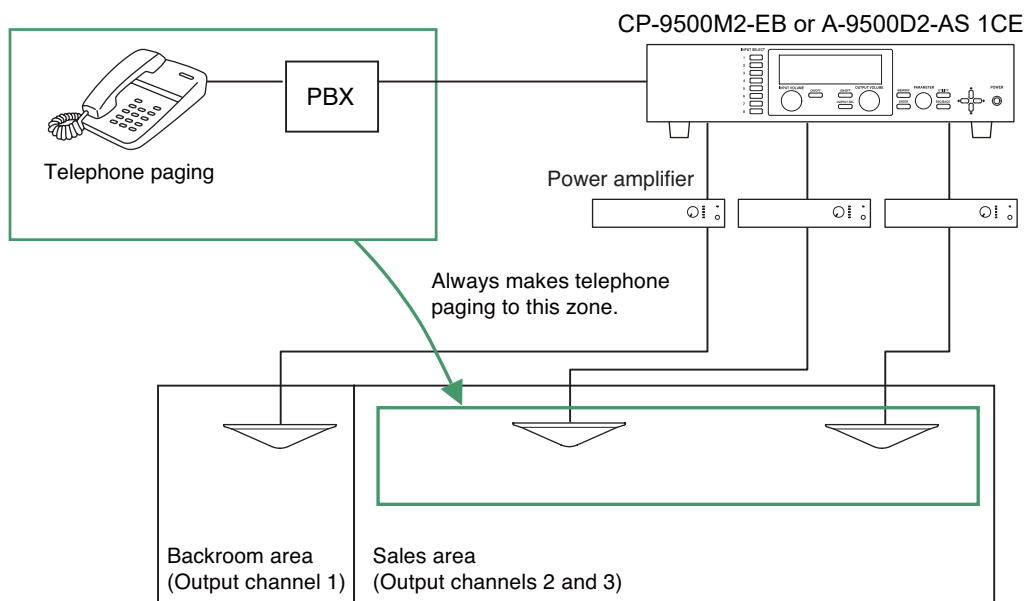

In this example, paging calls are made to the Output Channels 2 and 3 immediately after telephone paging has been activated.

[Telephone paging in MANUAL mode]

This is a method to directly select each output channel with the telephone key operation. In this mode, if the paging zone number and the output channel number are identical, paging zones can freely be combined with the key operation without the need to perform paging zone settings.

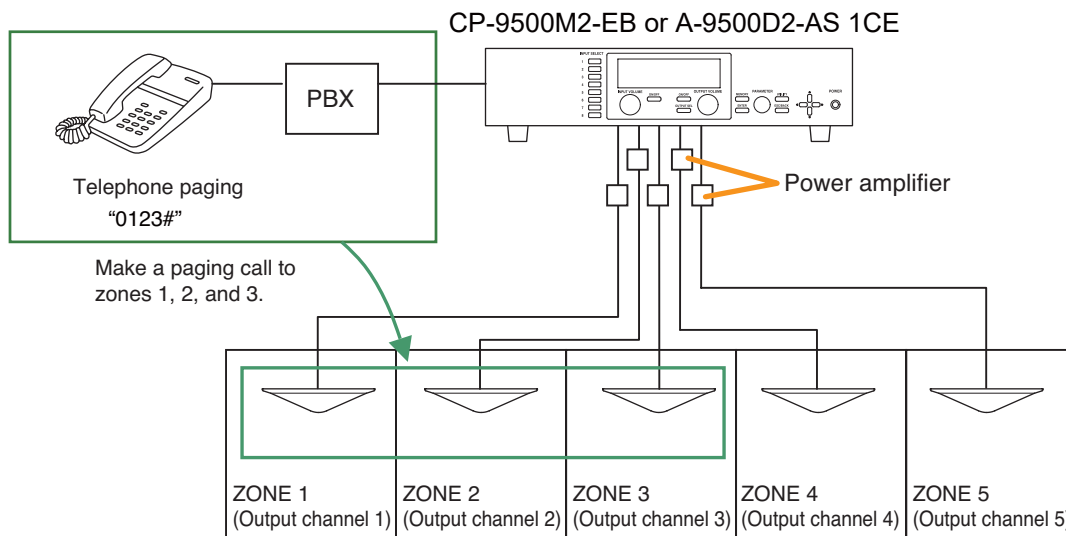

In this example, first make the paging initiation call (to be preset at the telephone) to the ZP-001T, then press "0, 1, #" to make paging calls to Output channel 1, press "0, 2, #" to Output channel 2, or press "0, 9, #" to all output channels.

To make paging by selecting two or more output channels, activate the paging, then press "0, 1, 2, 3, #" to make paging calls to Output channels 1, 2, and 3, similarly press "0, 1, 4, 5, #" to Output channels 1, 4, and 5.

[Telephone paging in GROUP mode]

In GROUP mode, group some output channels as paging group zones in advance. Up to 8 paging group zones can be recalled with the telephone key operation.

This mode is effective when assigning separate paging patterns to the zones such as when the multiple output channels are grouped to a single paging zone or when the paging zone range varies depending on conditions.

As an example, assign the outputs to the paging zones as follows in the paging group setting of the ZP-001T Input Settings.

- Assign Outputs 1, 2, and 5 to Zone 1.
- Assign Outputs 3 and 4 to Zone 2.
- Assign Outputs 6 and 7 to Zone 3.
- Assign Output 8 to Zone 4.

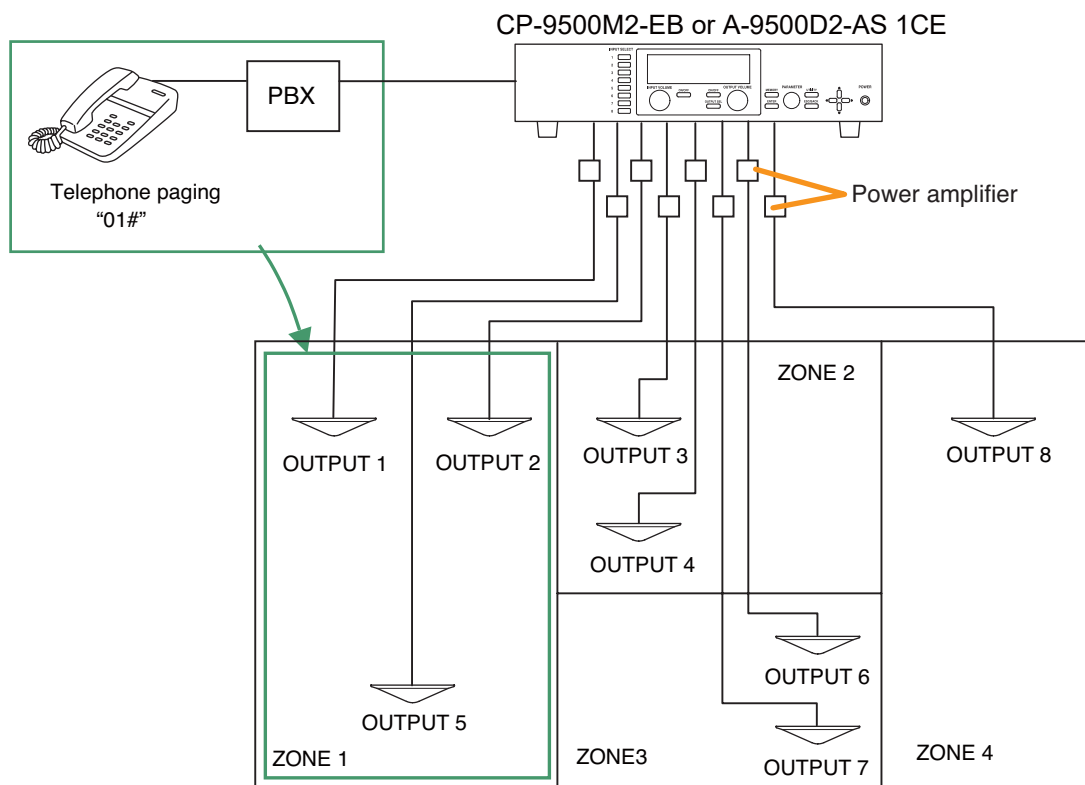

In such setting above, pressing "0, 1, #" causes the paging to be made to zone 1 consisting of Outputs 1, 2, and 5. Similarly, pressing "0, 3, #" causes the paging to be made to zone 3 consisting of Outputs 6 and 7.

8.2.3. Cross point ON/OFF control using the remote controller

When the cross point ON/OFF function has been assigned to the buttons on the remote controller, sound source to be output to the output channel can be selected by pressing the button.

Two control modes are made available for the cross point ON/OFF function: "EXCLUSIVE" and "SIMULTANEOUS."

Note: Use the PC Setting software when performing remote controller settings.

[EXCLUSIVE MODE]

Only a single cross point can be selected so as to output a single sound source to the output destination.

In this mode, only a single cross point control can be assigned to each button on the remote controller.

This is a convenient function to always select and output only one sound source using the remote controller installed at the output destination, which is ideal for individually selecting BGM or FGM sound source to be output to each partitioned zone (output destination).

(Example) Using as a BGM selector

Assign Input 1, 2, or 3 (BGM source) to be routed to Output 1 to each button on one remote controller. Likewise, assign the same input channel to be routed to Output 2 to each button on the other remote controller. (Refer to the PC Setting software screens below.)

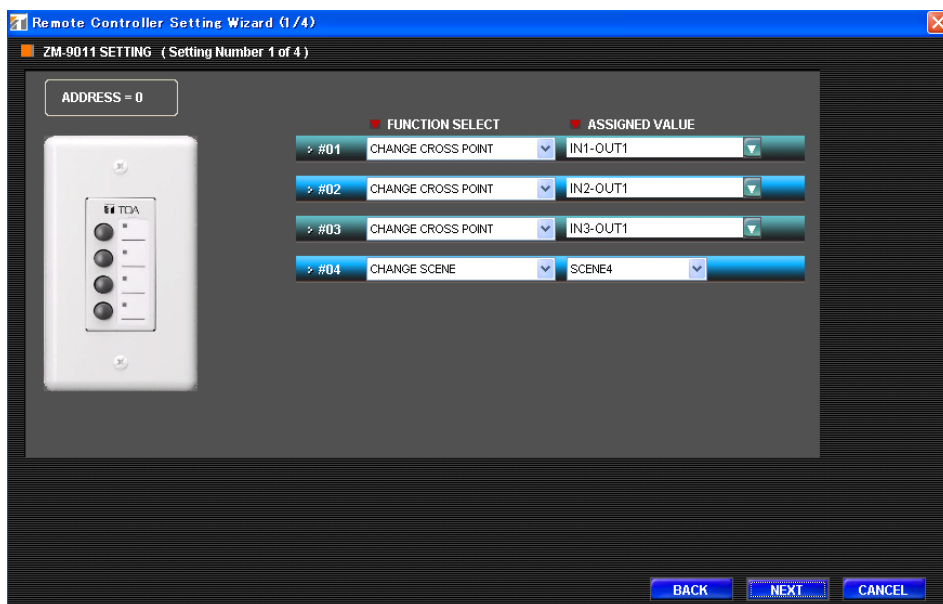

In such setting on [the previous page](#), the remote controller with address "0" functions as a remote controller that can switch Input 1, 2, or 3 for Output 1.

Similarly, the remote controller with address "1" functions a remote controller that can switch Input 1, 2, or 3 for Output 2.

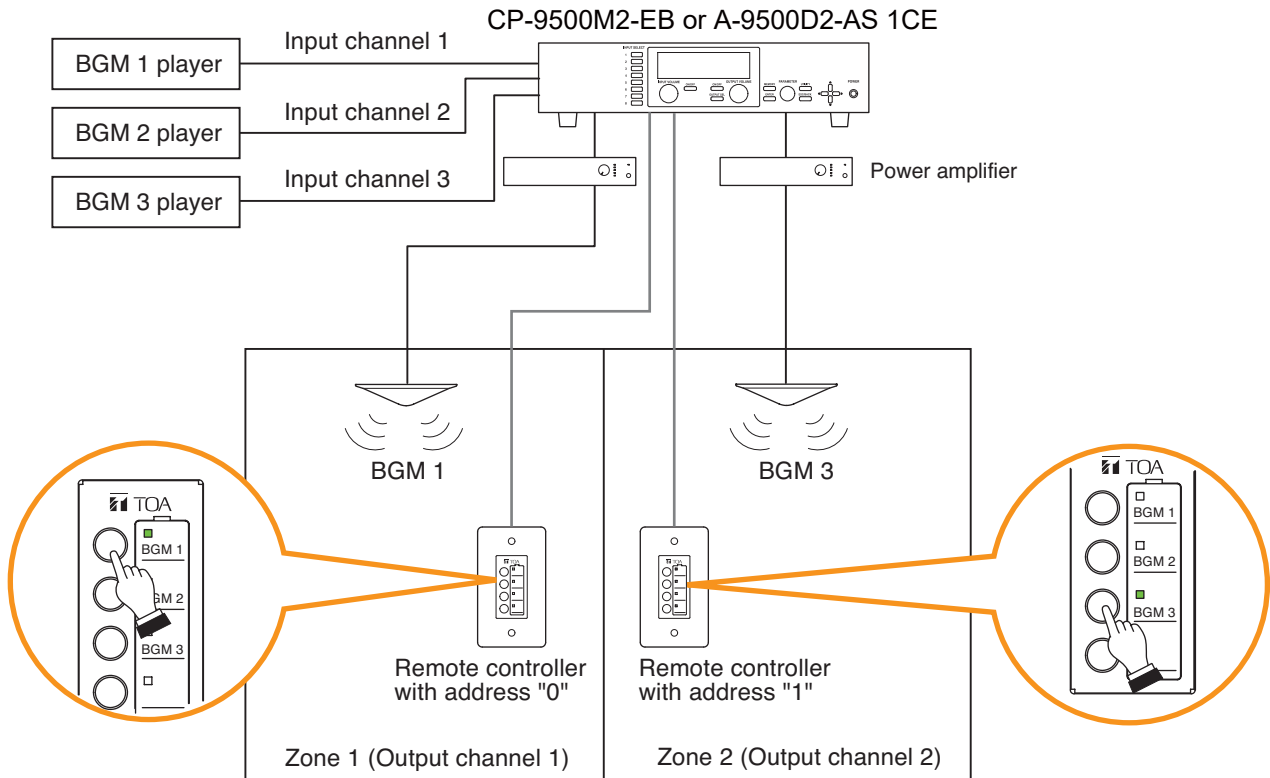

In the system above, the BGM sound source to be broadcast to Zone 1 can be selected with the buttons on the remote controller with address "0."

Similarly, the BGM sound source to be broadcast to Zone 2 can be selected with the buttons on the remote controller with address "1."

Notes

- When a scene memory is recalled while the cross point ON/OFF function is performed by the remote controller, the system operation is brought into the state set in the scene memory. (Scene memory takes precedence.)
- Paging input channel's cross point cannot be turned ON or OFF by the remote controller.

[SIMULTANEOUS MODE]

Arbitrary cross points assigned to the buttons on the remote controller can be turned ON or OFF. Arbitrary cross points can be assigned to a single button.

This is a convenient function to individually turn ON or OFF the sound source output channel by the remote controller installed at the output destination, which is ideal for selecting and outputting the multiple sound sources by pressing a button on the remote controller at the output destination.

(Example) Expanding the output destination

Perform remote controller settings using the PC Setting software.

Assign cross point control to 2 buttons on the remote controller: one for cross point control to route Input 1, 2, and 3 to Output 1, and the other for cross point control to route Input 1, 2, and 3 to Output 2. (Refer to the PC Setting software screen below.)

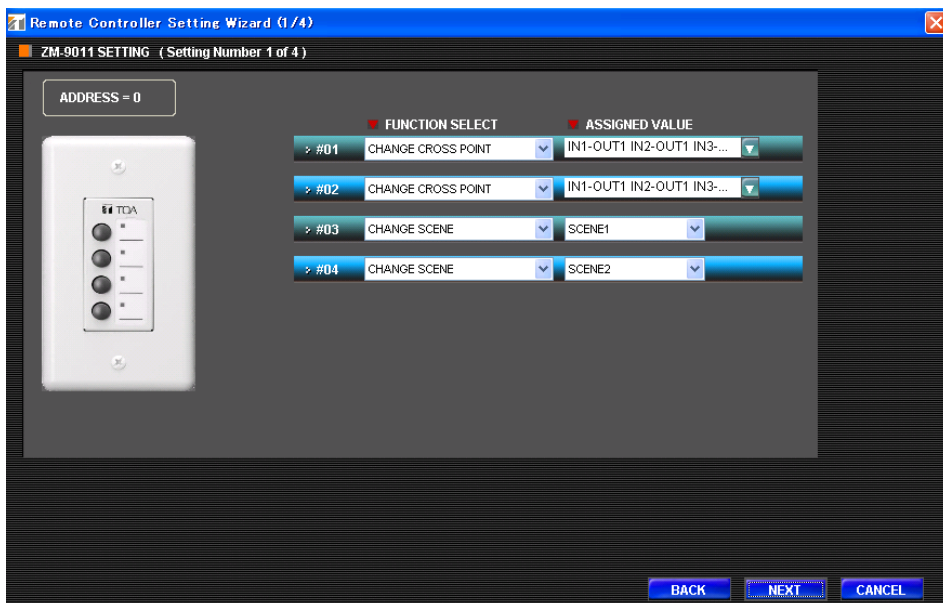

In such setting above, mixed audio signals of inputs 1, 2, and 3 can be broadcast to Zone 1 (Output 1) and Zone 2 (Output 2) as well through the remote controller operation.

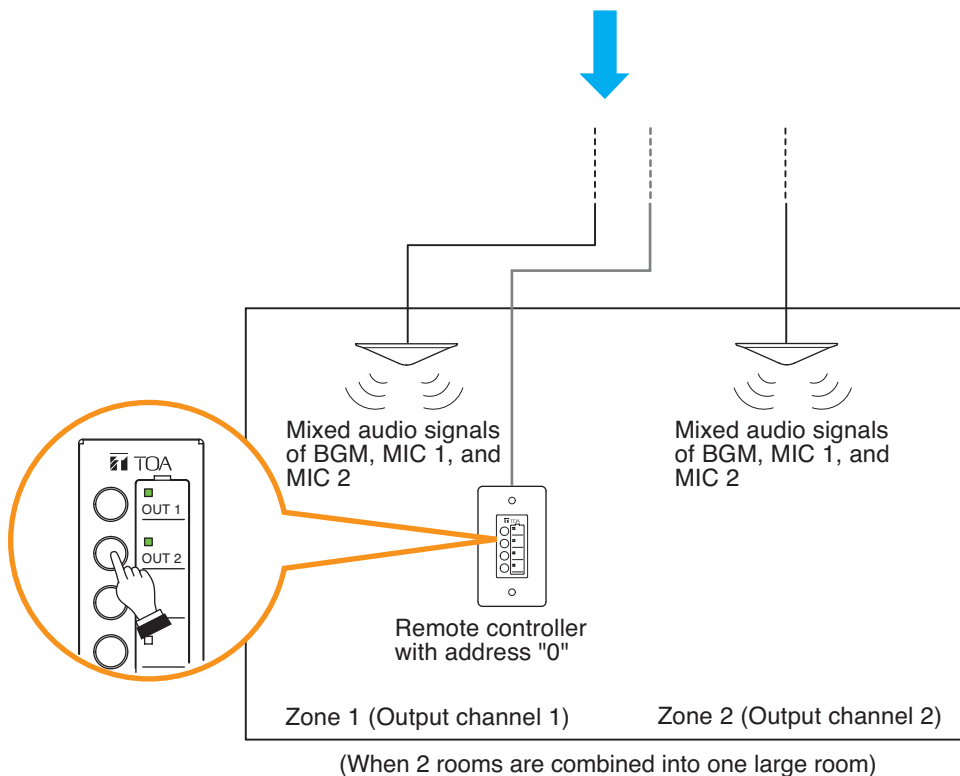
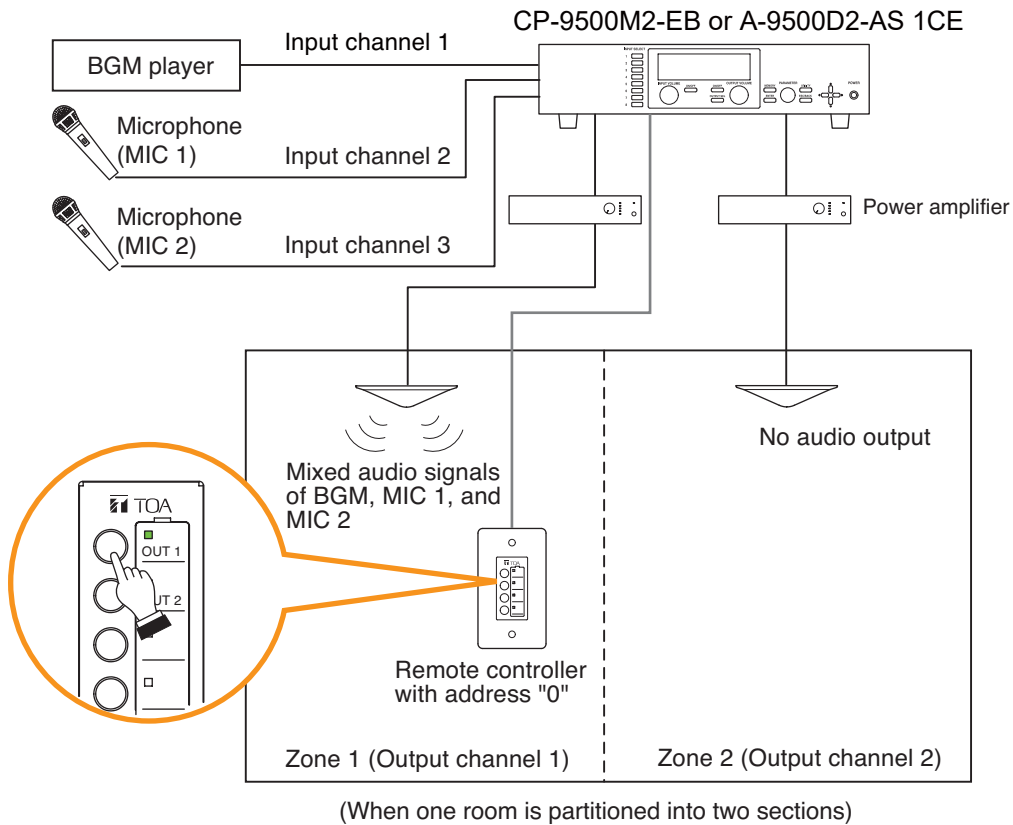

Notes

- When a scene memory is recalled while the cross point ON/OFF function is performed by the remote controller, the system operation is brought into the state set in the scene memory. (Scene memory takes precedence.)
- When the same cross points have been assigned to the multiple buttons, the said cross point can be controlled in the same operation each time any button is pressed.
- In-use indicator for the button lights when all the set cross points are turned to ON. When the multiple cross points are set to be controlled by a single button, and when some points are also redundantly set to be controlled by other buttons, the in-use indicator status may not match with the ON/OFF status of the cross point.
- Paging input channel's cross point cannot be turned ON or OFF by the remote controller.

8.3. Glossary

(1) Scene

A "Scene" is a unit of broadcast patterns when the 9000M2 amplifier is used as a mixer amplifier. Up to 32 types of patterns where various parameters are set can be saved into a Scene memory.

The saved Scene memory can be recalled, allowing operation by switching the broadcast patterns.

The following items describe the functions regarding the Scene.

(1-1) Gate function

Passes or cuts input signals depending on the input signal level. The gate opens when the input signal level exceeds the set gate threshold level, allowing the signal to pass through. When the input signal level falls below the gate threshold level, the gate closes after the set gate release time has passed.

This function helps to prevent unused microphone inputs from picking up noises.

The setting conditions are defined among the Gate function, NOM function, and VOX function. (Refer to p. 42.)

(1-2) NOM (Number of Open Microphones) attenuation function

The number of open microphones (NOM) is defined as the number of open-gate input channels.

The NOM attenuation function automatically adjusts an output gain depending on the number of open (active) microphones whose input signal level exceeds the set gate threshold level.

The output gain is attenuated by the value set on the Utility function setting screen (p. 78-C3) each time the number of open microphones doubles.

This function prevents acoustic feedback from easily occurring when 2 or more microphones' signals are simultaneously input.

The number of open microphones is obtained by counting all the NOM function-enabled input channels regardless of whether the paging settings have been performed or not for these input channels.

(1-3) ANC (Ambient Noise Control) function

Adjusts the amplifier's output volume in response to the change in ambient noise level. The output volume automatically changes as the ambient noise level goes above or below the set reference level.

This function allows the optimum output volume to be gained depending on the ambient noise level when broadcasts are made to places where the ambient noise level changes significantly.

(2) Paging function

Allows paging calls from the input with paging priority to go through to the designated output by means of the set paging trigger. Up to 32 paging patterns can be saved into the 9000M2 amplifier's internal memory, and retained even if the scene is switched.

Terminating the paging calls restores the original broadcast in a fade-in manner.

(2-1) Paging settings

A combination of outputs through which paging calls are made is referred to as "Paging group."

Each paging setting can contain one input, one paging trigger, a paging group comprised of up to 8 output channels, and a combination of up to 12 interlocked contact outputs.

(2-2) Paging trigger

An event to activate paging calls.

Four types of paging triggers by means of the followings can be set: control input terminals, telephone paging, remote activation (ZM-9001/9002, ZM-9011/9012/9013/9014), and VOX (Voice Operated Exchange).

(2-3) VOX (Voice Operated Exchange) function

A paging trigger using the level detection function. Setting the VOX function to ON for an input channel allows paging calls to be broadcast when the input signal level exceeds the set VOX threshold level.

If the input signal level keeps dropped below the set VOX threshold level, the paging calls are terminated after the set VOX release time has elapsed. This function enables paging calls to be made by use of a microphone or other input sources having no control function.

The gate and NOM functions cannot be used for the VOX-enabled input channels.

(2-4) Paging priority

Each paging input channel can be set for one of the priority levels 1 to 3.

When paging calls with higher priority interrupt those with lower priority or no priority, the volumes of the suppressed input channels are attenuated by the value set as ducker depth.

When multiple paging calls with the same priority level are activated simultaneously, calls follow the FIFO, LIFO, or MIX setting.

(2-5) FIFO/LIFO/MIX

The order of broadcasting paging calls can be set when multiple paging calls with the same priority level are redundantly activated. The factory default is set to the LIFO (Last-In First-Out) mode, which can be changed using the PC Setting software.

- FIFO (First-In First-Out) mode permits the preceding paging calls to take precedence to continue. The later paging calls are suspended and can be resumed after the preceding calls terminate.
- LIFO mode permits the later paging calls to take precedence to interrupt the preceding calls. The suspended paging calls that were being made can be resumed after the later calls terminate.
- MIX mode permits all paging calls to be mixed irrespective of the sequence of paging calls.

(2-6) Ducker depth

Sets the attenuation level on the suppressed input channels when paging calls with higher priority are made. The signal level of each input channel is reduced by the set ducker depth from the current Scene volume level.

This function allows paging calls to be emphasized by decreasing the volume of other broadcasts like BGM being made using a Scene during paging calls.

(2-7) Paging output volume

The output volume for paging calls can be set separately from that set for Scene memory. The output level is automatically switched to that set by the paging output volume when the paging call starts, and is restored to the level set by the Scene output volume when the paging call terminates. To emphasize paging calls over Scene broadcasts at an output destination, for example, the paging output volume can be set larger than the Scene output volume level.

(2-8) Busy input

The control input that functions as a trigger to terminate paging calls when the paging trigger function is assigned to the ZM-9001's or ZM-9002's button.

Paging calls are activated by pressing the ZM-9001's or ZM-9002's button irrespective of the busy input contact's status, and terminated when the busy input contact is opened.

(2-9) Paging prohibition setting

A control input can be set for the function to prohibit one output channel from broadcasting paging calls.

If the control input set for paging prohibition function is closed during broadcasts of a paging group that includes the paging prohibited output channel, the entire paging group calls are cancelled.

[Setting conditions among the Gate function, NOM function, and VOX function]

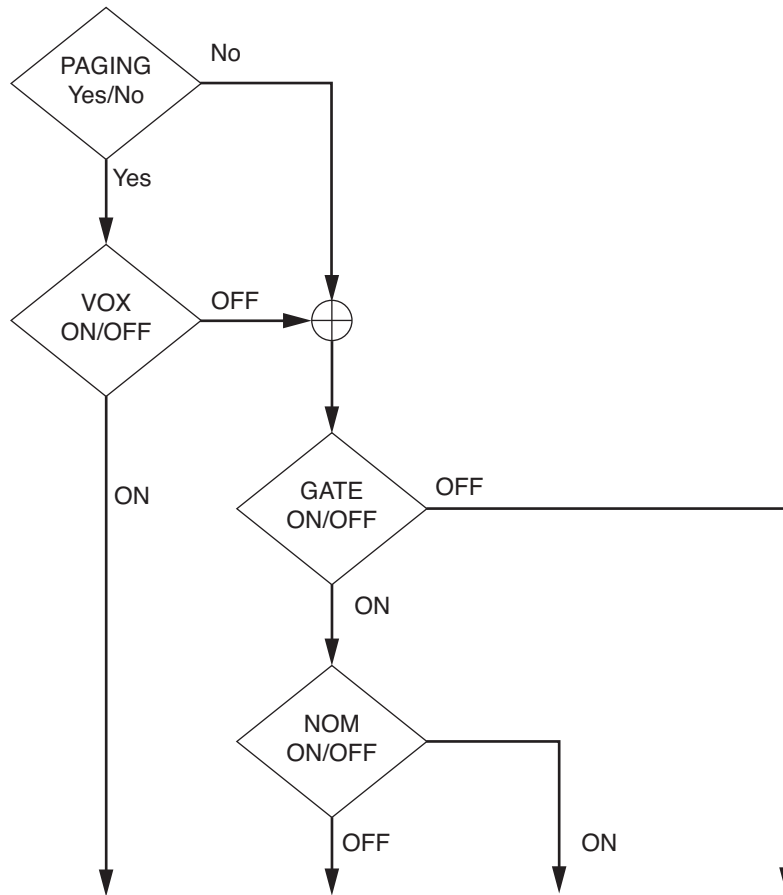

Input channel behavior	VOX-triggered Paging	GATE	NOM	Input without VOX, GATE, and NOM
Valid parameters				
Whole memory	Release Time (common to all Scene memories and all input channels, unique value in the system)		NOM Attenuation	
	VOX Threshold (Each input channel)			
Scene memory		GATE Threshold	GATE Threshold	

9. OPERATION

To operate the unit, you can use the saved Scene settings, or adjust the sound volume and tone or turn the input/output channels on or off through the front key operation or by way of remote control with the default settings as they are.

9.1. Basic Operation

9.1.1. Keys and knobs

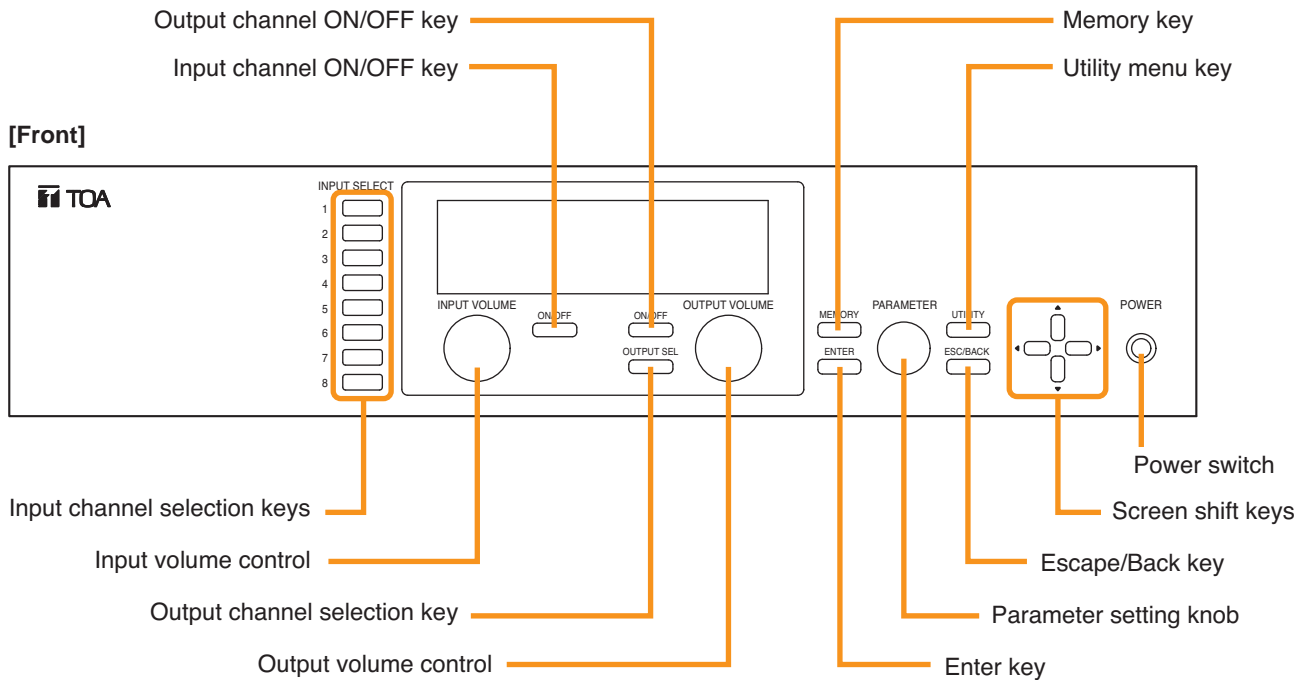

9.1.2. Power ON/OFF

Power is turned on when the power switch is pressed.
To turn off the power, hold down the power switch for 0.5 second or more.

Note

The power switch is a soft-switch, so the internal microcomputer is still operating even when the power switch is set to OFF.

9.1.3. Changing the input parameters

Step 1. Press the Input channel selection key to choose the input channel for which you want to change the volume from those with the illuminated Input channel ON/OFF indicator (channel number).
The selected channel's selection indicator (red dot) lights, and the channel name and volume level are displayed on the VFD screen.

Step 2. Adjust the input parameters.
Adjust the volume, bass, treble, or other input parameters. (Refer to [p. 54, "Input Setting Flow Chart."](#))

Note

To retain the set input parameters, be sure to save them in the Scene memory. Unless otherwise saved, all the set parameters are abandoned when the AC power supply is shut off.

9.1.4. Changing the output parameters

Step 1. Press the Output channel selection key to turn on the Output channel selection indicator (red dot) for the output channel for which you want to change volume.
Channels to be selected will change each time the Output channel selection key is pressed.
The channel name and volume level are displayed on the VFD screen.

Step 2. Adjust the output parameters.
Adjust the volume, bass, treble, or other output parameters.
(Refer to [p. 69, "Output Setting Flow Chart."](#))

Note

To retain the set output parameters, be sure to save them in the Scene memory. Unless otherwise saved, all the set parameters are abandoned when the AC power supply is shut off.

9.1.5. Input channel ON/OFF

Input channels alternate between ON and OFF with each depression of the Input channel ON/OFF key.
The channel is ON when the input channel ON/OFF indicator (channel number) lights.

9.1.6. Output channel ON/OFF

Output channels alternate between ON and OFF with each depression of the Output channel ON/OFF key.
The channel is ON when the Output channel ON/OFF indicator (channel number) lights.

Display Saver Mode

The VFD automatically enters the display saver mode if no key is operated for 20 minutes.
In this mode, "DISPLAY SAVER MODE. PRESS ANY KEY" indication scrolls sideways on the VFD.
The VFD reverts to normal if any key is pressed.
This one touch key operation performs only to restore the VFD to normal operating state. Subsequent key operation is effective for the amplifier operation.

9.2. Recalling Scene Memory

A "Scene" defines the unit of broadcast pattern.

Up to 32 patterns can be stored as Scene memory in the Scene memory bank, which can then be recalled.

Step 1. Press the Memory key to display the Scene memory setting screen.

Step 2. Press the Right shift key to display the Scene memory recall screen.

Step 3. Select with the Parameter setting knob the Scene memory bank number to be recalled.

Step 4. Press the Right shift key.
After recall completion, the Scene memory bank number and memory name are displayed.

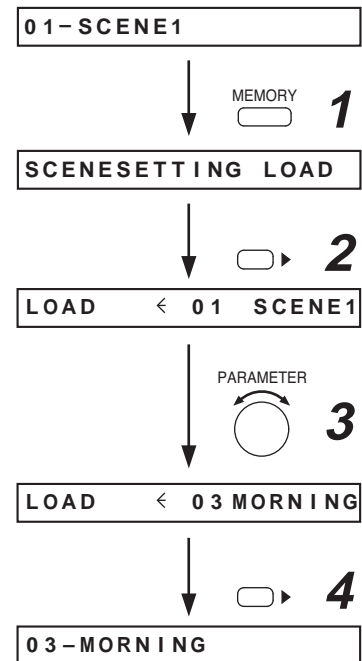

9.3. Making Zone Paging

To make the zone paging broadcast setting easier, clarify the following points before performing the setting.

- Input (source) to access paging broadcast
- Paging trigger and paging destination zones
- Equipment or function to be interlocked with paging

Paging settings are described below.

9.3.1. Zone paging using the D-001T, D-001R, or 900 series module

When using the D-001T, D-001R, or 900 series module for paging input, the paging function for the input channel must be set to ON in the input settings.

The paging-enabled input channel is set as a paging source, enabling the priority setting, paging trigger setting, and paging output destination setting.

For each setting item, refer to [p. 54, "Input Setting Flow Chart."](#)

Notes

- If the paging setting of an input channel is changed to OFF from ON during paging, the paging using the input channel is made to terminate.
- When the paging-enabled input channel is muted, paging can be initiated but the paging call will be muted.

[Paging initiation by means of the control terminal]

When the paging broadcast is initiated by closing the control terminal (make contact), the following operations are carried out.

- Step 1.** Close the paging function assigned-control input terminal.
The level of the mixed audio signal being broadcast at the



paging destination decreases.

- Step 2.** Make a paging call.

- Step 3.** Open the input terminal that has been closed in the step 1.
The level of the mixed audio signal being broadcast at the paging destination decreases.



Paging terminates, restoring the level of the mixed audio signal to the original value.

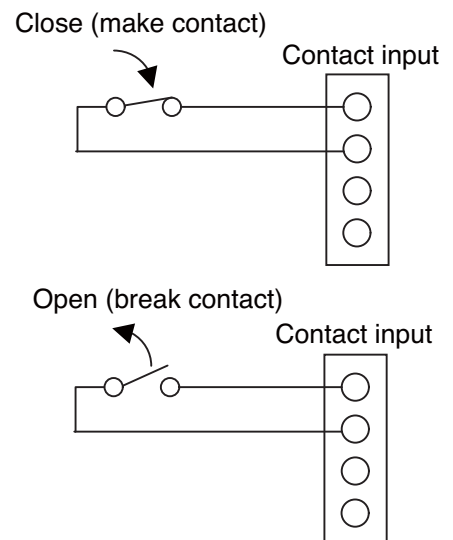

[Paging initiation by the ZM-9011, ZM-9012, ZM-9013, or ZM-9014 operation]

When assigning the paging activation function to the button on the remote control panel, pressing the function-assigned button causes the paging to initiate.

Step 1. Press the button on the remote control panel.



The corresponding indicator lights.
The level of the mixed audio signal being broadcast at the paging destination decreases.

When the selected channel is being used by other paging with higher priority level, the indicator does not light, indicating that paging cannot be initiated.

Example: ZM-9011

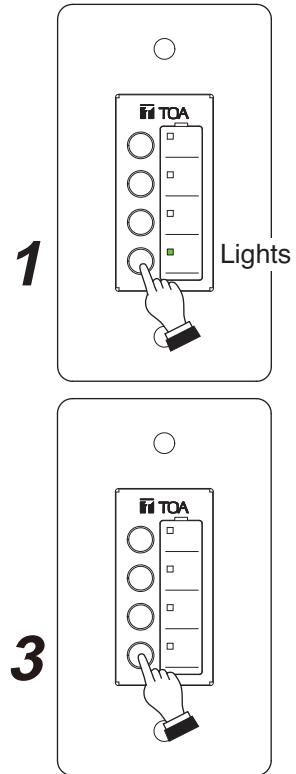

Step 2. Make a paging call.

Step 3. Press the button again to terminate the paging call, restoring the level of the mixed audio signal to the original value.

[Paging initiation using VOX (voice-operated switch) trigger]

Initiates paging when the paging audio signal is detected. There is no need to prepare a control input additionally as it starts paging by detecting the presence of audio signal. In this case, special attention should be paid to audio dropout at the beginning of paging call or unintentional start of paging. The VOX function is available when the D-001T or D-001R module is used.

Step 1. Speak into the paging microphone connected to the input of which trigger is set to VOX.

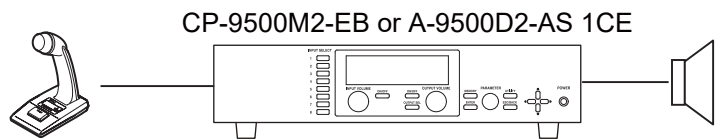

When the audio signal is detected, the paging call goes through, decreasing the level of the mixed audio signal being broadcast at the paging destination.

Step 2. Terminate the paging call.



If the audio signals are not detected for a specified period of time at the paging input, paging is made to terminate.

9.3.2. Zone paging using the ZP-001T module

This section describes the method of initiating zone paging from a PABX (extension telephone) using the ZP-001T Zone Paging Module. The following 2 operation modes are available for the ZP-001T: Paging port mode and Ring signal mode.

In both operation modes, when any of the following situations arises, the ZP-001T will not receive calls from the PABX or paging calls will be muted. Even when paging calls are muted, since the line is kept connected, they resume after the situation is restored.

- The input channel for the ZP-001T is turned off.
The ZP-001T will not receive calls from the PABX.
When this is done during paging calls by way of the ZP-001T, paging calls are muted.
- The input channel for the ZP-001T is muted by way of the control input.
The ZP-001T can receive calls from the PABX, but paging calls are muted.
When this is done during paging calls by way of the ZP-001T, paging calls are muted.
- Emergency-mute (EMG-MUTE) is activated by way of the control input.
The ZP-001T can receive calls from the PABX, but paging calls are muted.
When this is done during paging calls by way of the ZP-001T, paging calls are muted.

[Paging port mode]

Step 1. Activate the paging port from the extension telephone.

Since this method differs depending on the type of exchange, please read the instruction manual for the extension telephone.

When the paging port is activated and the control input terminal is closed, the ZP-001T module connects the line.

Step 2. Select the output channel.

The output selection method differs as follows depending on the paging method setting made on the VFD screen.

[Manual]

Press [0] first, followed by the output channel number ([1] – [8] or [9] when selecting all numbers simultaneously). Pressing the [#] key completes the output channel selection.

Example: To select Outputs 2 and 3, press [0] [2] [3] [#].

To make an all-zone call, press [0] [9] [#].

[Zone Group]

Press [0] first, followed by the group number [1] – [8]. Pressing the [#] key completes the group selection. Only a single group can be selected.

[Auto]

Automatically selects the output channel.

Step 3. Begin paging.

When the pre-paging tone is set to ON (p. 64-A26), begin paging after the tone sounds.

When the selected output channel is being used by other broadcast with higher priority level, a busy tone is heard from the handset, indicating that paging cannot be performed.

Step 4. Deactivate the paging port to terminate paging.

Since this method differs depending on the type of exchange, please read the instruction manual for the extension telephone.

[Ring signal mode]

Step 1. Make a call from the extension telephone to the ZP-001T module.

After a calling tone sounds twice, the ZP-001T receives the call and a callback tone is heard from the handset.

Step 2. Select the output channel.

The output selection method differs as follows depending on the paging method setting made on the VFD screen.

[Manual]

Press [0] first, followed by the output channel number ([1] – [8] or [9] when selecting all numbers simultaneously). Pressing the [#] key completes the output channel selection.

Example: To select Outputs 2 and 3, press [0] [2] [3] [#].

To make an all-zone call, press [0] [9] [#].

[Zone Group]

Press [0] first, followed by the group number [1] – [8]. Pressing the [#] key completes the group selection. Only a single group can be selected.

[Auto]

Automatically selects the output channel.

Step 3. Begin paging.

When the pre-paging tone is set to ON (p. 64-A26), begin paging after the tone sounds.

Paging can be performed within 30 seconds or 10 minutes after the call gets through. After this preset time has elapsed, the line is automatically disconnected.

When the selected output channel is being used by other broadcast with higher priority level, a busy tone is heard from the handset, indicating that paging cannot be performed.

Step 4. To terminate paging, press [0] [0] [#], and then replace the handset.

If dialing [0] [0] [#]: Pressing a first [0] terminates paging (a DTMF tone for the first [0] is output), and the ZP-001T disconnects the line after the [#] has been pressed.

If replacing the handset without dial operation: After a signal tone is transmitted about 3 times, the paging is terminated and the line disconnected.

9.4. Releasing Key Lock

The key lock function prevents the front-mounted keys or knobs from being tampered. (Refer to p. 90 "Key Lock Function Setting.")

You can temporarily operate the locked keys by entering a password to unlock them. Operation after password entry differs depending on the locked keys.

Step 1. Press the locked key.

The password entry screen is displayed with the flashing indication of the character entry position on the extreme left.

Note

If the front-mounted key operation is locked, the password entry screen appears after you press the input or output selection key and attempt to rotate the input or output volume control.

Step 2. Press the Enter key if no password has been set.

If the password has been set, enter it using the Input channel selection keys.

Entering a character causes the next character entry position to flash for character entry.

When the entered password is correct, the locked key is released. If the registered password is comprised of 1 to 3 characters, as soon as entered 1 to 3 characters agree with them, the locked key is released.

When released keys are those of the type related to input and output operations, they become temporarily operable, but revert to the locked state if they are left unused for 1 minute.

When utility-related keys are released, the key lock menu screen is displayed, clearing the password setting automatically.

Move to the screen for which you want to make a change. When wishing to lock the keys using the password even after the setting has been changed, set the password again. (Refer to p. 91 "Password setting.")

To simultaneously release all locked keys, set the all-key lock function to OFF on the all-key lock ON/OFF setting screen.

When the power switch is locked, pressing it displays the password entry screen. In this case, the power cannot be turned off without releasing the key lock.

Since the key lock function helps to prevent the front panel keys or knobs from being tampered, their operation can be performed by controls through the control input terminals even if the keys or knobs are locked.

(Example when input keys are locked)

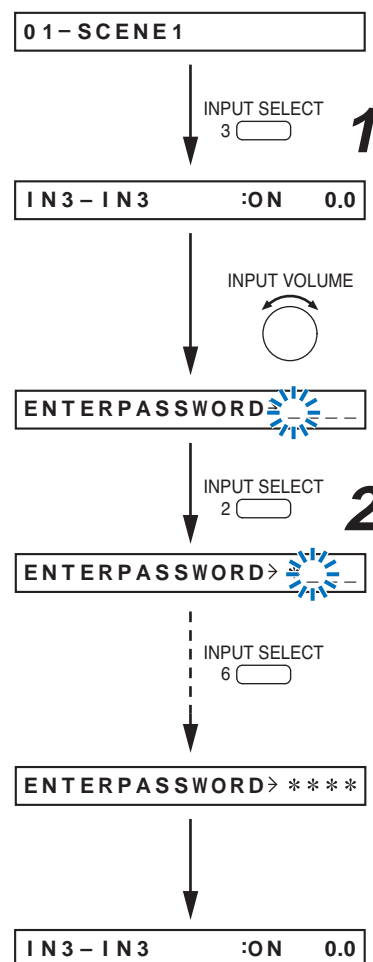

9.5. Operation Example

The operation procedure is described here using an example to change the output parameters after recalling the Scene memory when the output operation key is locked.

Step 1. Press the Memory key to display the Scene memory setting screen.

Step 2. Press the Right shift key to display the Scene memory recall screen.

Step 3. Select with the Parameter setting knob the Scene memory bank number to be recalled.

Step 4. Press the Right shift key.

Step 5. Press the output channel selection key.
The selected output channel status is displayed.

Step 6. Rotate the output volume control knob or press any screen shift key.
The password entry screen is displayed with the leftmost character position flashing.

Step 7. Enter the password with the input channel selection keys.
The locked key is released when the entered password is correct.

Step 8. Use the Up, Down, Left and Right shift keys to display the desired setting screen.

Step 9. Change the parameter with the Parameter setting knob.

Step 10. Press the Escape/Back key until the scene memory screen (normal use state screen) is displayed.
The display returns to the Scene memory indication screen.

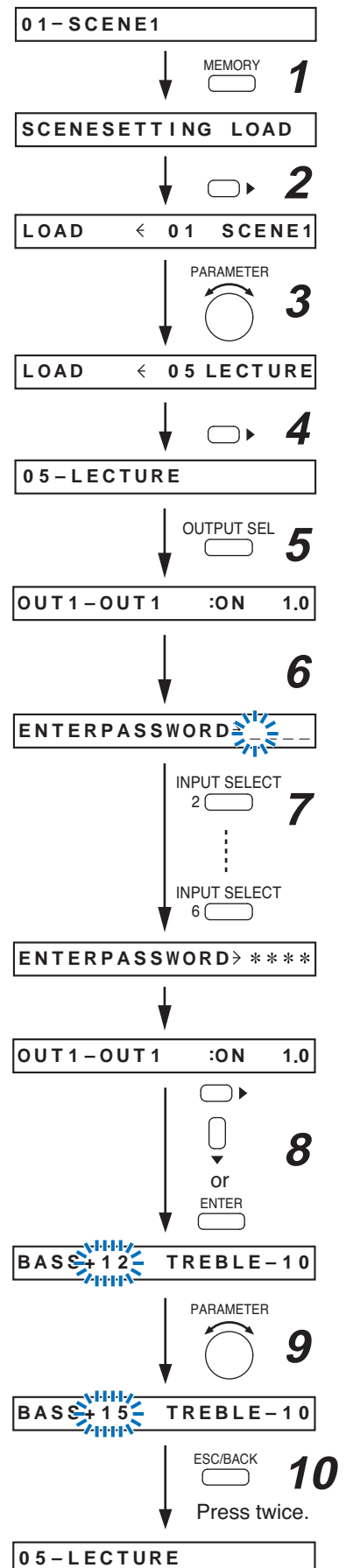

10. SETTINGS

Use the VFD screen, keys, and Parameter setting knob on the unit's front panel to make settings. Settings are categorized into two types of items: Items recommended to be set before operation (input settings, audio output settings, and UTILITY settings), and items that limit the front panel's key and knob operation (keylock settings, which are a part of UTILITY settings). If settings have been made before operation, all such settings can be stored using a Scene memory function. Ongoing paging calls are forced to terminate if paging function-related setting is changed during paging calls. Note that paging is not interrupted if settings other than paging function are changed.

All settings that can be made at the unit can also be made using the supplied dedicated software. (Refer to the separate setting software instruction manual.)

10.1. Setting Menu Configuration and Flow for Entering Each Screen

The setting menu consists of four major setting items: Input setting, Output setting, UTILITY setting, and Scene memory setting. The method to enter each setting screen differs as shown below. Refer to each individual setting flow chart for details such as the parameter settings and key operations to shift the screen.

10.1.1. Input setting configuration

Set paging ON/OFF, input sensitivity, and bass/treble parameters for each individual input channel. Pressing the Input channel selection key (1 - 8) corresponding to the desired channel number at the normal use state screen allows you to enter its input channel setting screen. Setting items differ depending on the modules used for input channels.

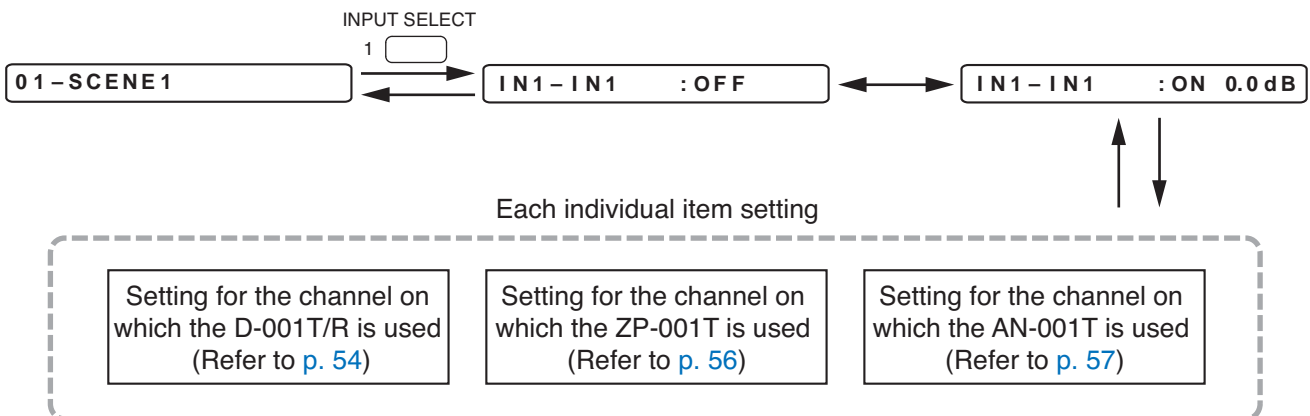

10.1.2. Output setting configuration

Set parameters such as bass/treble, equalizer, and compressor for each individual output channel. Press the Output channel selection key several times at the normal use state screen to display the desired channel number. The display proceeds to its output channel setting screen.

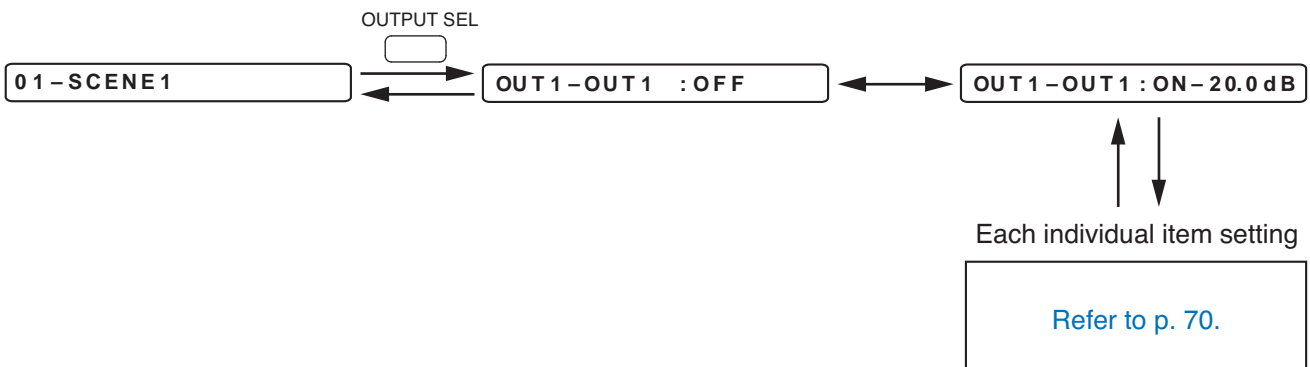

10.1.3. Utility setting configuration

Perform stereo link settings for the input and output channels, function assignment to the control input and output terminals, keylock settings, and password setting.

Press the Utility key at the normal use state screen to proceed to the setting screen.

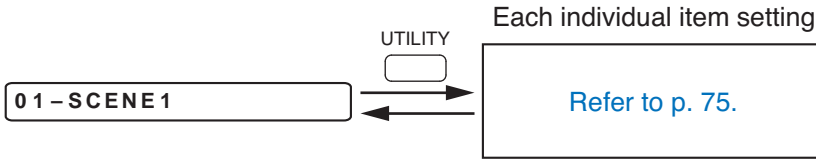

10.1.4. Scene memory setting configuration

Perform scene memory recall, scene memory save, and scene memory erasure.

Press the Memory key at the normal use state screen to proceed to the setting screen.

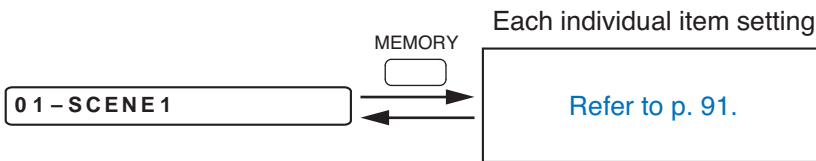

10.1.5. Confirming set items

Each setting item consisting of the related elements to be set is confirmed by pressing the Enter key or right shift key after these elements have been all set.

If the setting flow is reversed half way through a setting item, the parameters having been set so far are abandoned.

Example: Paging setting on the D-001T or D-001R use channel (Refer to [p. 55-A16 - A20.](#))

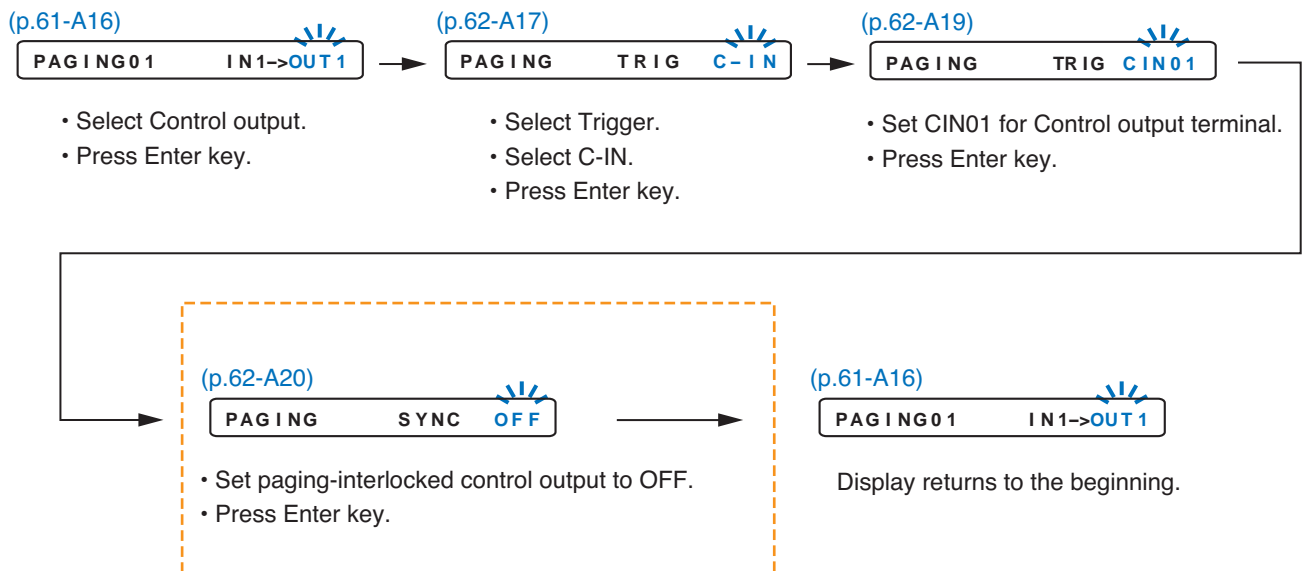

All parameters set for the paging item are confirmed at this step and written in the amplifier's internal memory.

The indicator lights when the preset scene is selected. The indicator goes off when the Function button is pressed, and goes off when the scene from other devices.

10.2. Input Setting Flow Chart

Setting items differ depending on the model used for input channels. Refer to this page when the ZP-001T or D-001R is used, and p. 56 when the ZP-001T is used, and p. 57 when the AN-001T is used.

10.2.1. Input setting flow chart for the channel on which the D-001T or D-001R is used

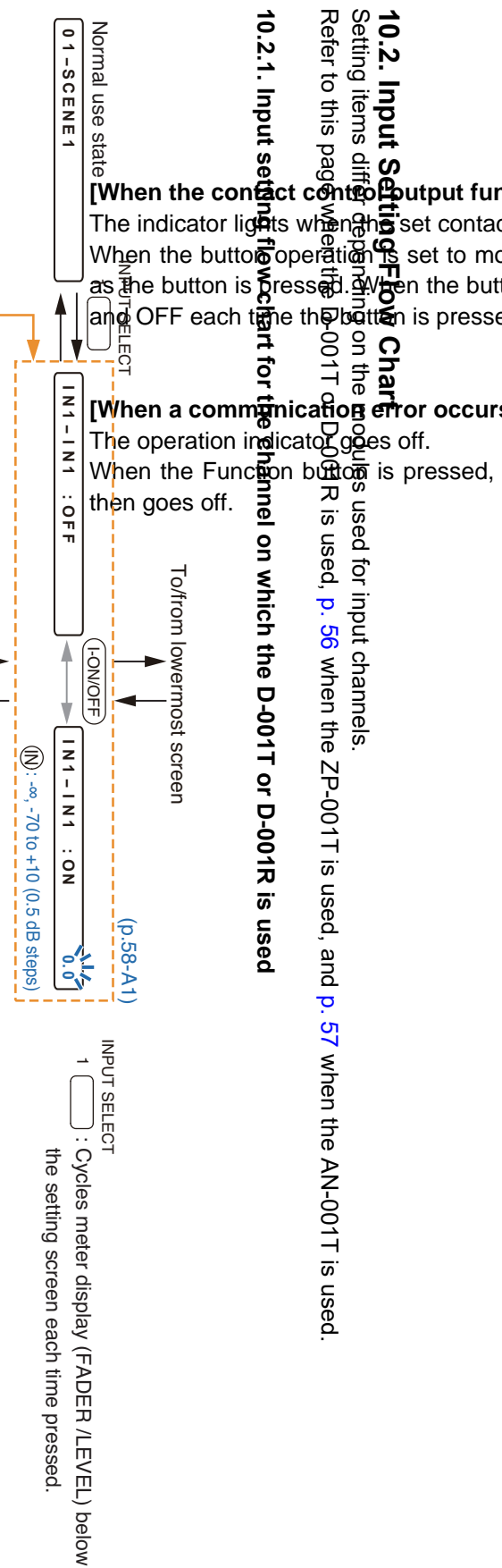

27. Set volume level indicators

Indicate the volume level set by the volume control knob (28). The set levels are shown by 7-point LED indicators, each of which shows -30 dB, -20 dB, -10 dB, -5 dB, 0 dB, +5 dB, and +10 dB from the bottom.

28. Volume control

Adjusts the volume level of input or output channel.

29. Address selector [0 – F]

Sets the ZM-9014 address.

Be sure to set the different address among other remote control panels.

Addresses are arranged numerically (0 – 9), and alphabetically (A – F) in this order.

30. Data terminals [LINK A/B D+, D-]

Connect the communication line to the RC-001T.

As the communication line has polarities, match both polarities of the ZM-9014 and the RC-001T when connected.

Each 2 identical terminals is provided, and the identical terminals are internally connected to one another. Either set of terminals can be used for connection to other controller.

31. 24 V DC input terminals [24 V +, -]

Connect the DC power cable from the RC-001T.

Each 2 identical terminals is provided, and the identical terminals are internally connected to one another. Either set of terminals can be used for connection to other controller.

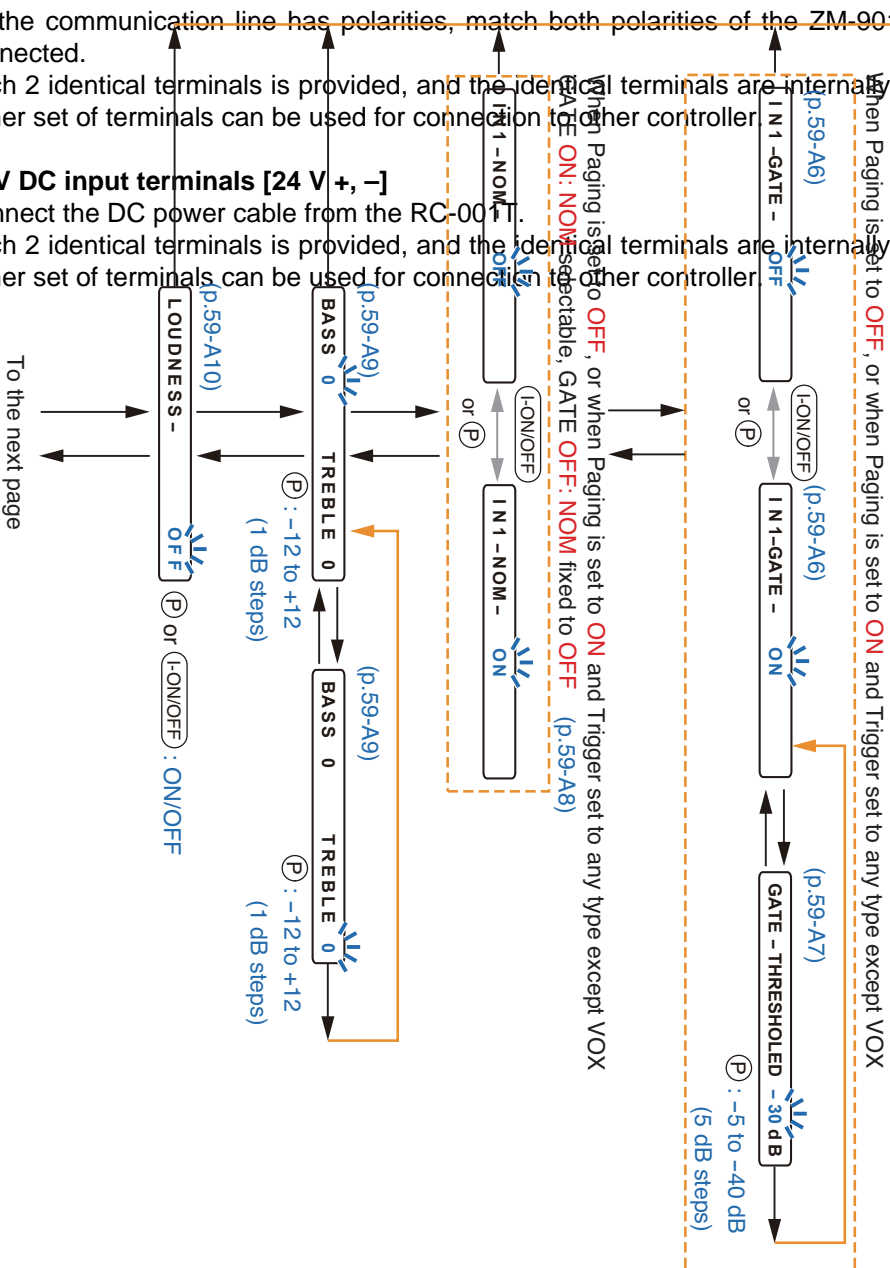

The screen display examples may differ from actual displays. The on-screen indications shown in blue are variable parameters by key operation. The symbols in the figure represent the following key operation.

- ↑ ↓ : Screen shift keys (up and down)
- : Screen shift key (right) or ENTER key
- ← : Screen shift key (left) or ESC key
- (P) : PARAMETER knob
- (N) : INPUT VOLUME knob
- (ON/OFF) : Input channel ON/OFF key
- (O-ON/OFF) : Output channel ON/OFF key

From the previous page

When set to OFF, setting menu at right is not displayed.

Goes to the next band setting.

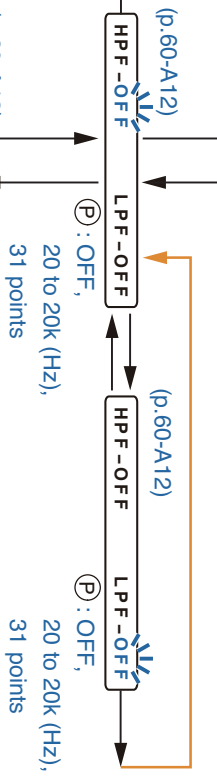
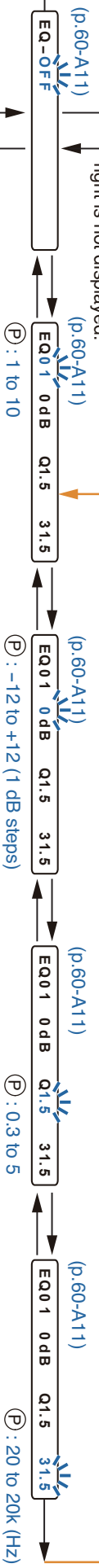

COMPRESSOR-OFF (p.60-A13) (P: OFF, 1, 2, 3, 4, 5)

Only when Paging is set to ON



Only when Paging is set to ON

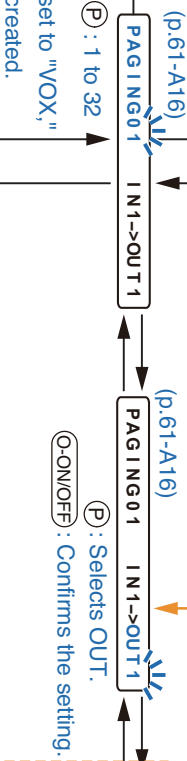

When Trigger is set to "VOX," only one can be created.

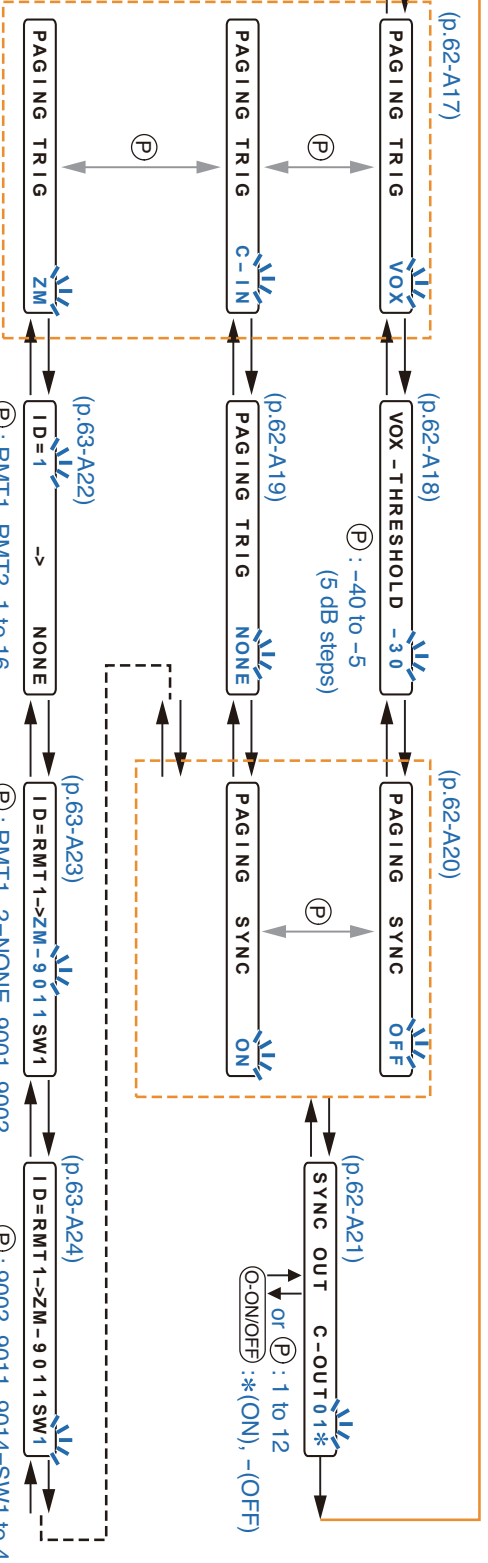

When Paging is set to OFF

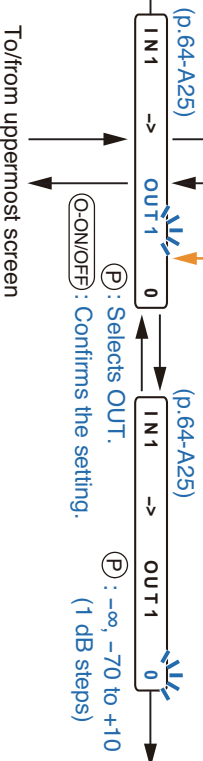

To/from uppermost screen

10.2.2. Input setting flow chart for the channel on which the ZP-001T is used

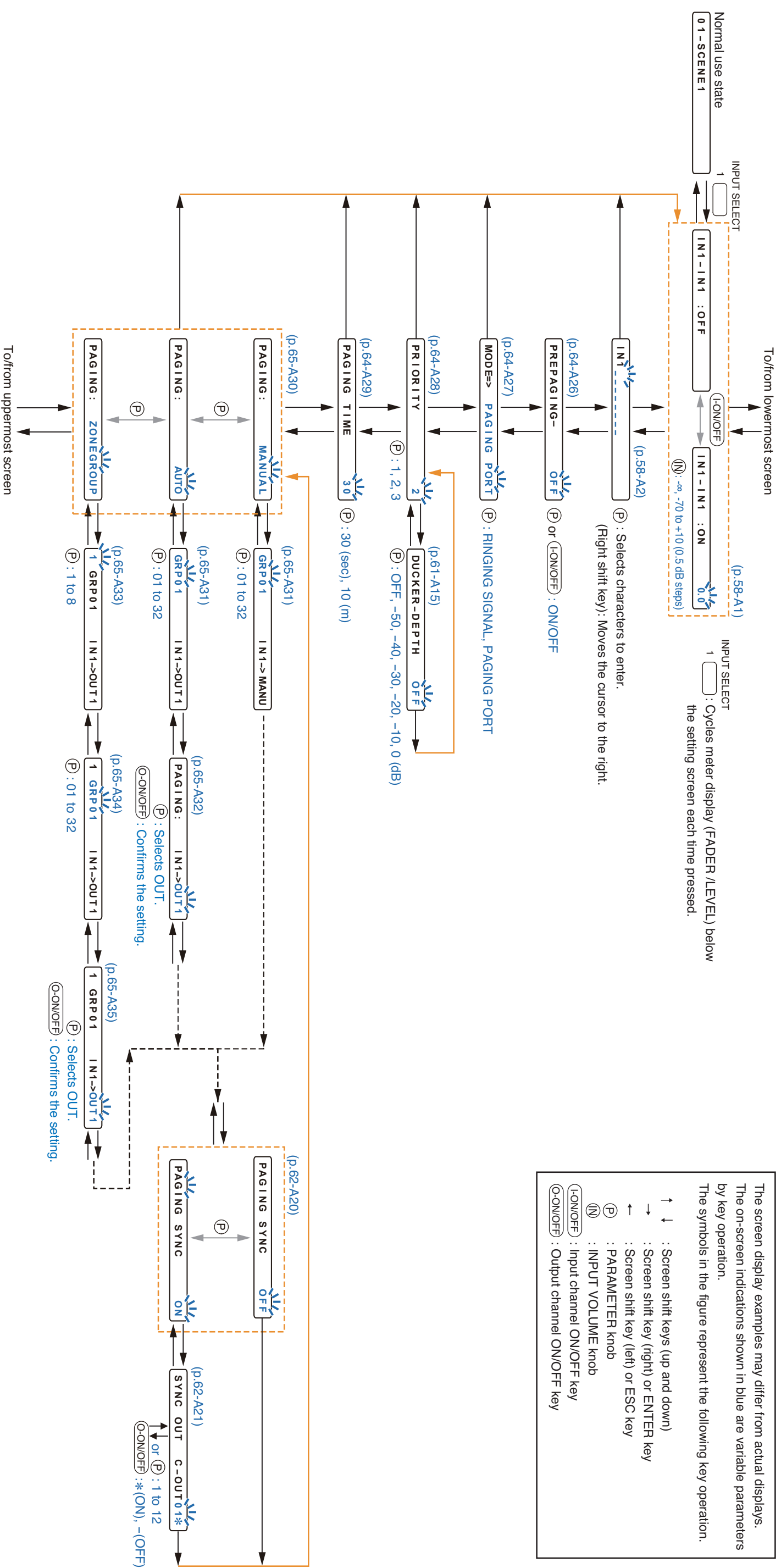

10.2.3. Input setting flow chart for the channel on which the AN-001T is used

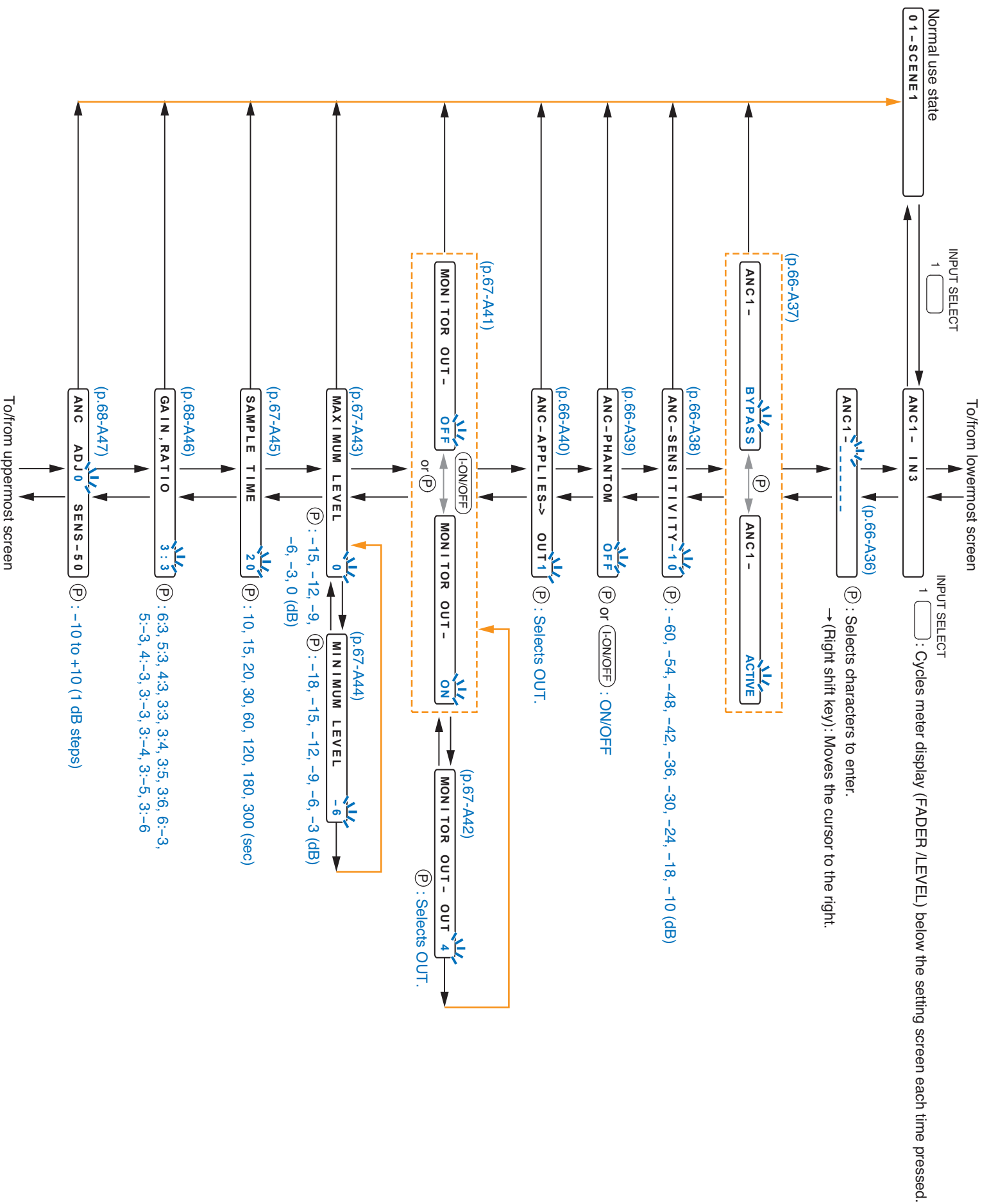

The screen display examples may differ from actual displays. The on-screen indications shown in blue are variable parameters by key operation. The symbols in the figure represent the following key operation.

- ↑ ↓ : Screen shift keys (up and down)
- : Screen shift key (right) or ENTER key
- ← : Screen shift key (left) or ESC key
- (P) : PARAMETER knob
- (ON/OFF) : Input channel ON/OFF key

10.2.4. Input setting items

Unless otherwise specified, use the Parameter setting knob for each parameter selection.

(A1) Input gain setting

IN1 – IN1 : ON 0.0

Select the input channel using the Input channel selection key.
 Confirm the selection by setting the Input channel ON/OFF key to ON.
 Set the input channel gain using the Input volume control.

Setting Range	Input Channel Selection	1 – 8 (default: 1)
	Channel Control	ON (default), OFF
	Channel Gain	$-\infty$, -70.0 dB to $+10.0$ dB (default: 0.0 dB), 0.5 dB steps

(A2) Input channel name setting

IN1 _ _ _ _ _

The flashing portion is the cursor position for entering channel name characters.
 Select a character from the alphanumeric character list by rotating the Parameter setting knob, then move the cursor with the Right shift key.
 Entering a new name overwrites the existing name, if there is.
 To delete the character, select [_] (under-bar) with the Parameter setting knob. A space character cannot be entered.
 Up to 7 characters can be used to set the name.
 Even when an input channel name has been set, some setting screens display the channel number, not the set name.
 When an input channel is stereo-linked (p. 78-C1), the name entry screen only for the odd channel is displayed.

Setting Range	7 characters (default: IN1 – 8)
---------------	---------------------------------

(A3) Paging ON/OFF setting

PAGING OFF

Set whether or not to use this input channel for paging.
 When set to ON, this channel can be used as paging source, enabling priority setting and zone paging setting as well.

Setting Range	ON, OFF (default)
---------------	-------------------

Note

Changing the parameter in this item during paging broadcast interrupts all paging calls being made through any channel.

(A4) Input Sensitivity setting (when the D-001T/R is used)

IN1 – SENSITIVITY – 10

Select the input sensitivity from the following 9 levels depending on the input sources:

Setting Range	-60 , -54 , -48 , -42 , -36 , -30 , -24 , -18 , -10 dB (default)
---------------	--

**(A5) Phantom power ON/OFF setting
(when the D-001T/R is used)**

IN 1 – PHANTOM OFF

Set the Phantom power to ON or OFF.

Notes

- When the module is the D-001R, this function can be set to ON but cannot be output.
- The Phantom power cannot be set to ON for the stereo-linked input channel.

Setting Range	ON, OFF (default)
---------------	-------------------

- ON: Supplies the phantom power. (except D-001R)
- OFF: Does not supply the phantom power.

**(A6) GATE setting (On the D-001T/R input channel, when Paging is set to OFF,
or when Paging is set to ON and Trigger set to any type except VOX.)**

IN 1 – GATE – OFF

Set the GATE function to ON or OFF.

Setting Range	ON, OFF (default)
---------------	-------------------

- ON: Activates the GATE function.
- OFF: The GATE function does not work.

(A7) GATE threshold setting (when GATE is set to ON)

GATE – THRESHOLD – 30 dB

Rotate the Parameter setting knob to set the GATE threshold.

Setting Range	–40 dB to –5 dB (default: –30 dB), 5 dB steps
---------------	---

**(A8) NOM attenuation ON/OFF setting (On the D-001T/R input channel, when Paging
is set to OFF, or when Paging is set to ON, Trigger to any type except VOX, and GATE to ON.)**

IN 1 – NOM – OFF

Set the NOM attenuation function (p. 40 "Glossary") to ON or OFF.

This function relates to the Gate ON/OFF setting and Gate threshold setting that appear later.
The NOM attenuation cannot be set to ON for the stereo-linked input channel.

Setting Range	ON, OFF (default)
---------------	-------------------

- ON: Activates the NOM attenuation function.
- OFF: The NOM attenuation function does not work.

(A9) BASS and TREBLE settings (when the D-001T/R is used)

BASS 0 TREBLE 0

Rotate the Parameter setting knob to set gains.

Press the Right or Left shift key to select BASS or TREBLE, of which gain value that flashes can be adjusted.

Setting Range	–12 dB to +12 dB (default: 0 dB), 1 dB steps
---------------	--

(A10) Loudness compensation setting (when the D-001T/R is used)

LOUDNESS – OFF

Rotate the Parameter setting knob to set the loudness compensation function ON/OFF.
Setting ON boosts low frequencies.

Setting Range	ON, OFF (default)
---------------	-------------------

(A11) EQ ON/OFF, Band number, Gain, Q, and Center frequency settings (when the D-001T/R is used)

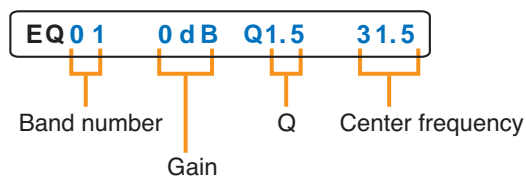

The indications on the right of "EQ" turn on and off as the Parameter setting knob is rotated. When the indication is displayed, EQ is ON and a band number, gain, Q, and center frequency are displayed in this order from left to right. Use the Parameter setting knob to change each parameter, and the Left and Right keys to move the setting items.

Setting Range	EQ	ON, OFF (default)
	EQ Band Number	01 to 10 (default: 01)
	Gain	-12 dB to +12 dB (default: 0 dB), 1 dB steps
	Q	0.3, 0.5, 0.7, 1, 1.5 (default), 2, 3, 5
	Center Frequency	20, 25, 31.5 (default), 40, 50, 63, 80, 100, 125, 160, 200, 250, 315, 400, 500, 630, 800, 1 k, 1.25 k, 1.6 k, 2 k, 2.5 k, 3.15 k, 4 k, 5 k, 6.3 k, 8 k, 10 k, 12.5 k, 16 k, 20 kHz

(A12) HPF and LPF settings (when the D-001T/R is used)



Rotate the Parameter setting knob to set the cut-off frequencies. Press the Right or Left shift key to select HPF or LPF, of which parameter that flashes can be adjusted.

Setting Range	HPF	OFF (default), 20, 25, 31.5, 40, 50, 63, 80, 100, 125, 160, 200, 250, 315, 400, 500, 630, 800, 1 k, 1.25 k, 1.6 k, 2 k, 2.5 k, 3.15 k, 4 k, 5 k, 6.3 k, 8 k, 10 k, 12.5 k, 16 k, 20 kHz
	LPF	

(A13) Compressor setting (when the D-001T/R is used)



Setting Range	OFF (default), 1, 2, 3, 4, 5
---------------	------------------------------

Use the compressor to prevent power amplifier overload or to produce more easily heard sound by averaging the audio level. The number shows the compressor's effectiveness level as shown in the table on the next page, which can be set by rotating the Parameter setting knob.

- DEPTH = 1 (Peak limiter)
Provides a peak limiter function that protects amplifiers and speakers against damage caused by an excessive signal input.
This level is suited to speech applications.
- DEPTH = 2 (Peak limiter)
Provides a peak limiter function that protects amplifiers and speakers against damage caused by an excessive signal input.
This level is suited to musical applications.
- DEPTH = 3 (Sonic normalizer)
Equalizes the sound volume of reproduced BGM among CDs or pieces of music by boosting small sounds and lowering big sounds, making the entire sound volume uniform.
This level is suited to BGM reproduction.
- DEPTH = 4 (Speech leveler)
Makes paging calls easier to hear by equalizing the difference in speech signal volume that may result from individual differences in speaker voice volumes or variations in speaker-to-microphone distances.
Since the volume is extensively corrected, the feedback margin narrows, making it liable to occurrences of feedback. Therefore, special care must be taken when installing microphones and speakers.
This level is suited to microphone speech applications.

• DEPTH = 5 (Speech leveler)

Makes paging calls easier to hear by equalizing the difference in speech signal volume that may result from individual differences in speaker voice volumes or variations in speaker-to-microphone distances.

This level 5 is more effective than level 4. Since the volume is extensively corrected, the feedback margin narrows, making it liable to occurrences of feedback. Therefore, special care must be taken when installing microphones and speakers.

This level is suited to microphone speech applications.

Parameter	DEPTH = 1	DEPTH = 2	DEPTH = 3	DEPTH = 4	DEPTH = 5
Threshold 1	-20 dB	-20 dB	-30 dB	-78 dB	-78 dB
Threshold 2	-10 dB	-10 dB	-25 dB	-30 dB	-30 dB
Ratio 1	1 : 1	1 : 1	1 : 1	1 : 2	1 : 2.6
Ratio 2	2 : 1	2 : 1	1.25 : 1	1.25 : 2	2.5 : 1
Ratio 3	20 : 1	20 : 1	5 : 1	8 : 2	20 : 1
Attack time constant	0.1 msec	0.1 msec	0.1 msec	0.1 msec	0.1 msec
Release time constant	100 msec	1 msec	5 msec	100 msec	100 msec
COMP. output level	0 dB	0 dB	0 dB	+12 dB	+24 dB

Note: For the compression characteristics diagram, refer to [p. 137](#).

(When Paging is set to ON)

(A14) Priority setting

PRIORITY 3

Set the priority levels for paging broadcasts.

Priority can be set to one of 3 levels, and Priority 1 is the highest.

Setting Range	1, 2, 3 (default)
---------------	-------------------

When the same priority level is set for two or more input channels, paging calls are made according to the FIFO, LIFO (default), or MIX setting, which can only be set using the supplied PC software.

(When Paging is set to ON)

(A15) Ducker depth setting (when the AN-001T is not used)

DUCKER-DEPTH OFF

Set how much the input signal for this channel should be attenuated when there is a paging input with higher priority than that of the currently selected input channel.

Setting Range	OFF (default), -50, -40, -30, -20, -10, 0 dB
---------------	--

The minus figures in dB represent amount to attenuate input signals. The larger the minus figures, the larger the amount of attenuation. Selecting "OFF" sets the attenuation to infinity, while selecting "0" sets to no attenuation, permitting all input signals to be mixed and output.

(A16) Paging group setting

PAGING01 IN1->OUT1

Sets the paging group, in which the paging broadcast routing from an input to output(s) is determined.

Setting Range	Paging group No.: 1 - 32 Input channel: 1 - 8 Output channel: 1 - 8 (two or more channels settable)
---------------	---

Note

Changing the parameter in this item during paging broadcast interrupts all paging calls being made through any channel.

(A17) Trigger setting
 (for the channel on which the module
 other than the ZP-001T is used)

PAGING TRIG C-IN

(A17) Trigger setting
 (for the channel on which the ZP-001T
 is used)

PAGING TRIG ZP

Set the trigger to initiate paging. Type of trigger differs depending on the module that uses the channel.

Setting Range	Modules except the ZP-001T, D-001T and D-001R: C-IN (default) D-001T, D-001R: C-IN (default), VOX, ZM ZP-001T: ZP (default)
---------------	---

- VOX: Voice Operated Switch
 Enables paging if the audio input signal exceeds a preset level. (When the D-001T or D-001R is used)
 When Trigger is set to VOX, be sure to also set the Gate function for the paging input channel to ON.
- C-IN: Enables paging while the control input terminal is closed.
- ZP: Enables paging using the ZP-001T. (When the ZP-001T is used)

(When the D-001T/R is used and the gate function is ON)

(A18) VOX threshold level setting

VOX - THRESHOLD -30

Set the input sensitivity to activate the gate function (p. 40 "Glossary").

Setting Range	-40 to -5 dB (default: -30 dB), 5 dB steps
---------------	--

(A19) Paging trigger control input terminal setting

PAGING TRIG NONE

Sets the control input terminal to be used for paging trigger.

Setting Range	NONE, CIN01 - 12
---------------	------------------

(A20) Paging interlock setting

PAGING SYNC ON

Sets whether or not to activate the control output synchronizing with paging initiation.

Setting Range	OFF (default), ON
---------------	-------------------

(A21) Paging-interlocked output terminal setting

SYNC OUT C-OUT 01 -

Sets the control output terminal to be activated when the paging-interlocked output is set to ON in the above item. Select one of 1 through 12 using the setting knob, and set the paging-interlocked output to ON or OFF using the output channel ON/OFF key.

When set to OFF

SYNC OUT C-OUT 01 -

When set to ON

SYNC OUT C-OUT 01*

Setting Range	1 - 4 (12: when C-001T is used) , - (OFF: default), * (ON)
---------------	--

(A22) Remote controller connection terminal or ID setting

ID = 1 -> **NONE**

When the remote controller to initiate paging is the ZM-9001 or ZM-9002, set its connected control input terminal on the amplifier's rear (REMT VOL1 or REMT VOL2 terminal: RMT1 or REMT2 on the VFD). When the ZM-9011, ZM-9013, or ZM-9014 is used, designate its unit ID number.

Setting Range	RMT1, RMT2 (when ZM-9001 or ZM-9002 is used) 1 - 16 (When ZM-9011, ZM-9013, or ZM-9014 is used)
---------------	--

(A23) Remote controller model number setting

ID = RMT 1->ZM - 9 0 0 1 SW1

Select the model number of paging initiating remote controller from the Zone manager or Remote controller of data communication type.

Setting Range	NONE, ZM-9001, ZM-9002 (when ZM-9001 or ZM-9002 Zone Manager is used) NONE, ZM-9011, ZM-9013, ZM-9014 (when ZM-9011, ZM-9013, or ZM-9014 Remote Control Panel is used)
---------------	---

(A24) Remote controller's paging button setting

ID = RMT 1->ZM - 9 0 0 1 SW1

Sets the button number to be used for paging initiation.

Setting Range	1 - 4 (when ZM-9002, ZM-9011, or ZM-9014 is used) 1 - 6 (when ZM-9011 is used) 1 - 8 (when ZM-9013 is used)
---------------	---

A busy signal is required when the ZM-9001 or ZM-9002 is used for paging initiation as shown below.

[Paging initiation and busy signal]

If external equipment is used for broadcasts, and when it provides a busy signal during broadcasts, paging is made as shown in the timing chart below.

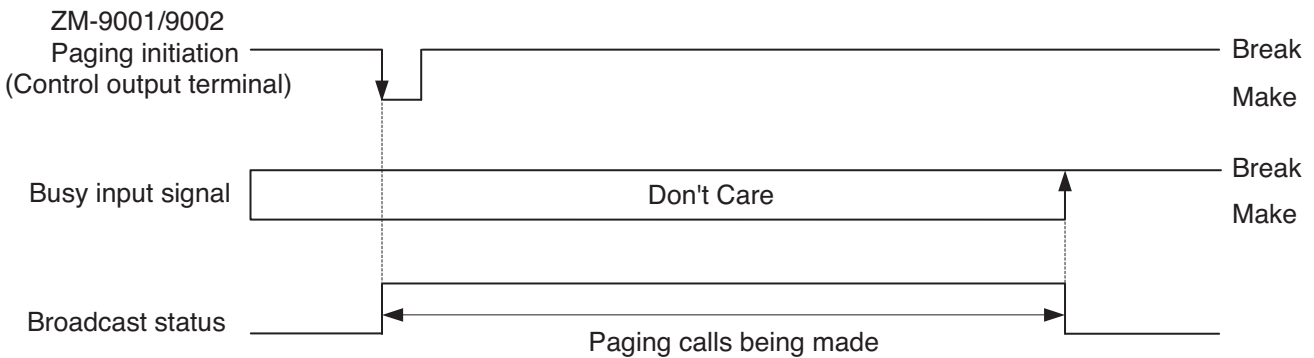

The trigger to initiate paging is to press the front-mounted button on the ZM-9001 or ZM-9002. (Regardless of whether the busy input is closed or open)

The trigger to terminate paging is the change of the busy input state from closed to open. (Regardless of whether the control output at the paging activation is closed or open.)

In this case of setting, the busy signal input terminal setting (below) follows after Remote controller's paging button setting.

BUSY - IN -> **C - IN 1**

Set the control input terminal to accept busy signals.

Note: It is not possible to set the same contact redundantly for each paging pattern.

Setting Range	1 - 4 1 - 12 (when C-001T is used)
---------------	---------------------------------------

(A25) Output assignment and level settings

(when the D-001T/R is not used and the paging is set to OFF)

IN1 -> OUT1 0

Set which output channel in what level an audio source at the currently selected input channel should be output to.

Select the output channel from Channel 1 to 8 (maximum) with the Left or Right shift key, and set the output level with the Parameter setting knob. By repeating this procedure, output level can be assigned to 2 or more output channels.

Pressing the output channel ON/OFF key alternately switches the level between "0 dB" and "-∞."

Setting Range	Output Channel	OUT1 – 2, Max. 8 when T-001Ts are used (default: OUT1)
	Assigned Output Level	0 dB (default) -∞, -70.0 dB to +10.0 dB, 1 dB steps

(A26) Pre-paging tone ON/OFF setting (when the ZP-001T is used)

PREPAGING- OFF

Set whether or not to sound a one-tone chime before paging.

Setting Range	ON, OFF (default)
---------------	-------------------

When set to OFF, the tone does not sound at the paging telephone, either.

(A27) Operation mode setting (when the ZP-001T is used)

MODE=> PAGING PORT

Select the method of activating paging.

Setting Range	PAGING PORT (default), RING SIGNAL
---------------	------------------------------------

- PAGING PORT: Paging is operated if a start signal (no-voltage make signal) is received from the paging port when the connection between the unit and PABX is established.
- RING SIGNAL: Paging is operated if an IR signal is received when the connection between the unit and PABX is established. The ZP-001T module functions as a telephone.

(A28) Priority setting (when the ZP-001T is used)

PRIORITY 2

Set priority level of the sound source set to the paging input.

Setting Range	1, 2 (default), 3
---------------	-------------------

Note

Changing the parameter in this item during paging broadcast interrupts all paging calls being made through any channel.

(A29) Paging duration time setting

PAGING TIME 30

Sets the paging duration time.

This setting prevents broadcasts from unintentional continuation due to erroneous operation in telephone paging made using the ZP-001T module.

Setting Range	30 sec (default), 10 min
---------------	--------------------------

(A30) Paging method setting

PAGING : MANUAL

Selects the paging method from MANUAL, AUTO, and GROUP as follows:

MANUAL: Directly select the OUTPUT for paging.

AUTO: One paging group can be set.

ZONEGROUP: Up to 8 paging groups can be set.

Setting Range	MANUAL, AUTO, ZONEGROUP
---------------	-------------------------

**(A31) Paging group selection
(when set to MANUAL)**

GRP 0 1 IN 1->MANU

**(A31) Paging group selection
(when set to AUTO)**

GRP 0 1 IN 1->OUT 1

Select the group to which outputs for telephone paging are assigned.

This group is saved into the amplifier as a paging group.

Setting Range	GRP01 - 32
---------------	------------

(A32) Paging output setting

PAGING : IN 1->OUT 1

Sets the paging outputs.

Select the output with the Parameter knob, then confirm it with the output ON/OFF key.

Setting Range	1 - 8
---------------	-------

(A33) Group selection key setting (when set to ZONEGROUP)

1 GRP 0 1 IN 1->OUT 1

Sets the telephone key to initiate telephone paging.

Setting Range	1 - 8
---------------	-------

(A34) Paging group selection (when set to ZONEGROUP)

1 GRP 0 1 IN 1->OUT 1

Select the group to which outputs for telephone paging are assigned.

Each group assigned to one of telephone keys 1 through 8 is saved into the amplifier as a paging group.

Setting Range	GRP01 - 32
---------------	------------

(A35) Paging output setting

1 GRP 0 1 IN 1->OUT 1

Sets the paging outputs.

Select the output with the Parameter knob, then confirm it with the output ON/OFF key.

Setting Range	1 - 8
---------------	-------

(A36) Input channel name setting

ANC 1 - _ _ _ _ _

The flashing portion is the cursor position for entering channel name characters. Select a character from the alphanumeric character list by rotating the Parameter setting knob, then move the cursor with the Right shift key. Entering a new name overwrites the existing name, if there is. To delete the character, select [_] (under-bar) with the Parameter setting knob. A space character cannot be entered. Up to 7 characters can be used to set the name. Even when an input channel name has been set, some setting screens display the channel number, not the set name. When an input channel is stereo-linked (p. 78-C1), the name entry screen only for the odd channel is displayed.

Setting Range	7 characters (default: IN1 – 8)
---------------	---------------------------------

(A37) ANC operation ON/OFF setting (when the AN-001T is used)

ANC 1 - ACTIVE

Set the ANC operation (p. 40, "Glossary") on or off.

Setting Range	ACTIVE, BYPASS (default)
---------------	--------------------------

- ACTIVE: Activates the ANC function.
- BYPASS: ANC function does not work.

(A38) Input Sensitivity setting (when the AN-001T is used and ANC operation is set to ACTIVE)

ANC - SENSITIVITY - 1 0

Select the input sensitivity from the following 9 levels depending on the input sources:

Setting Range	-60, -54, -48, -42, -36, -30, -24, -18, -10 dB (default)
---------------	--

(A39) Phantom power ON/OFF setting (when the AN-001T is used and ANC operation is set to ACTIVE)

ANC - PHANTOM OFF

Set the Phantom power to ON or OFF.

Setting Range	ON, OFF (default)
---------------	-------------------

- ON: Supplies the phantom power.
- OFF: Does not supply the phantom power.

(A40) ANC-activated output setting (when the AN-001T is used and ANC operation is set to ACTIVE)

ANC - APPLIES -> OUT 1

Set on which output channel the ANC function works.

Setting Range	OUT1 – 2, Max. 8 when T-001Ts are used (default: OUT1)
---------------	--

(A41) Monitor ON/OFF setting (when the AN-001T is used and ANC operation is set to ACTIVE)

MONITOR OUT - OFF

Set to ON or OFF the monitor function that permits the ambient noise input signal to be output.

Setting Range	ON, OFF (default)
---------------	-------------------

- ON: Outputs signals to be monitored.
- OFF: Does not output signals to be monitored.

**(A42) Monitor output channel selection
(when the AN-001T is used, the ANC operation is ACTIVE, and the Monitor function is ON)**

MONITOR OUT - OUT 1

Select the output channel on which signals to be monitored are output.

Setting Range	OUT1 - 2, Max. 8 when T-001Ts are used (default: OUT1)
---------------	--

(A43) Highest output level setting (when the AN-001T is used and ANC operation is set to ACTIVE)

MAXIMUM LEVEL 0

Set the upper limit of the ANC-activated output level.

Setting Range	-15, -12, -9, -6, -3, 0 (default) dB Note: Settable level is 3 dB or more above the lower limit (lowest output level).
---------------	--

(A44) Lowest output level setting (when the AN-001T is used and ANC operation is set to ACTIVE)

MINIMUM LEVEL -6

Set the lower limit of the ANC-activated output level.

Setting Range	-18, -15, -12, -9, -6 (default), -3 dB Note: Settable level is 3 dB or more below the upper limit (highest output level).
---------------	---

(A45) Sampling time setting (when the AN-001T is used and ANC operation is set to ACTIVE)

SAMPLE TIME 20

Set the required time to measure ambient noise. The ambient noise level is determined by being averaged over the set measuring time. When the measuring time is long, the output level changes slowly with the ambient level. However, the change in output level is not susceptible to a sudden change in ambient noise level.

Setting Range	10, 15, 20 (default), 30, 60, 120, 180, 300 sec
---------------	---

(A46) Gain ratio setting (when the AN-001T is used and ANC operation is set to ACTIVE)

GAIN , RATIO 3 : 3

Set the degree of change in the output sound level to that in ambient noise level, which is displayed as the ratio "ambient noise level : output level."

Setting Range 6:3, 5:3, 4:3, 3:3 (default), 3:4, 3:5, 3:6, 6:-3, 5:-3, 4:-3, 3:-3, 3:-4, 3:-5, 3:-6

When the ratio of output level to ambient noise level is great, the degree of change in output level becomes greater than that in ambient noise level.

The greater the amount of change in output level is, the faster the output level reaches the upper limit or lower limit, causing the sound volume not to change any more.

Contrary, when the ratio of output level to ambient noise level is small, the degree of change in output level becomes smaller than that in ambient noise level.

When the ratio of output level is positive, the output level increases as the ambient noise level increases.

When the ratio of output level is negative, the output level decreases as the ambient noise level increases.

For example, when the ratio "3 : 3" is selected, the output volume level increases by 3 dB as the ambient noise level increases by 3 dB.

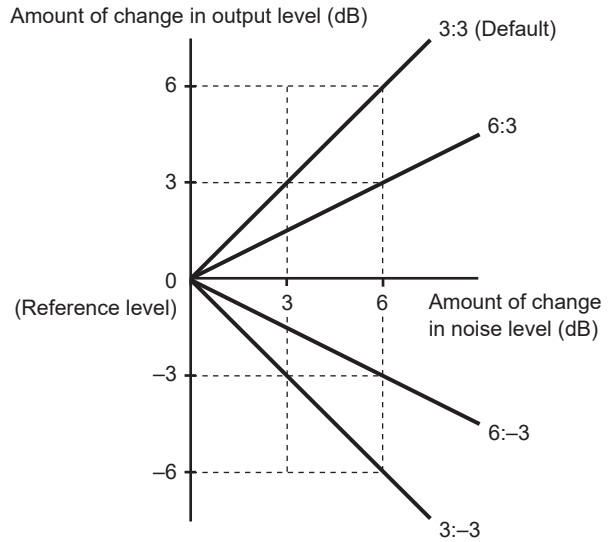

(A47) Reference level adjustment (when the AN-001T is used and ANC operation is set to ACTIVE)

ANC ADJ 0 SENS - 5 0

ANC adjustment value Reference level

Fine adjust the reference level which is a starting point for detecting the amount of change in ambient noise level.

Though the reference level is automatically determined according to the input sensitivity set on its setting screen, this adjustment screen allows the reference level to be manually adjusted under the actual condition that ambient noise is collected by a microphone.

Make the adjustment for the broadcast zone when it is quietest.

Adjust the on-screen ANC adjustment value with the Parameter setting knob so that the on-screen reference level becomes "0." Increase the ANC adjustment value when the reference level is higher than 0, and decrease when the reference level is lower than 0.

Setting Range -10 to +10 dB (default: 0 dB), 1 dB steps

Note

The reference level cannot be adjusted within the setting range if it is over +10 or below -10.

In this case, reset the input sensitivity (p. 57, p. 66-A38) to the value above the current level when the reference level is higher than 10, and below the current level when smaller than -10.

10.3. Output Setting Flow Chart

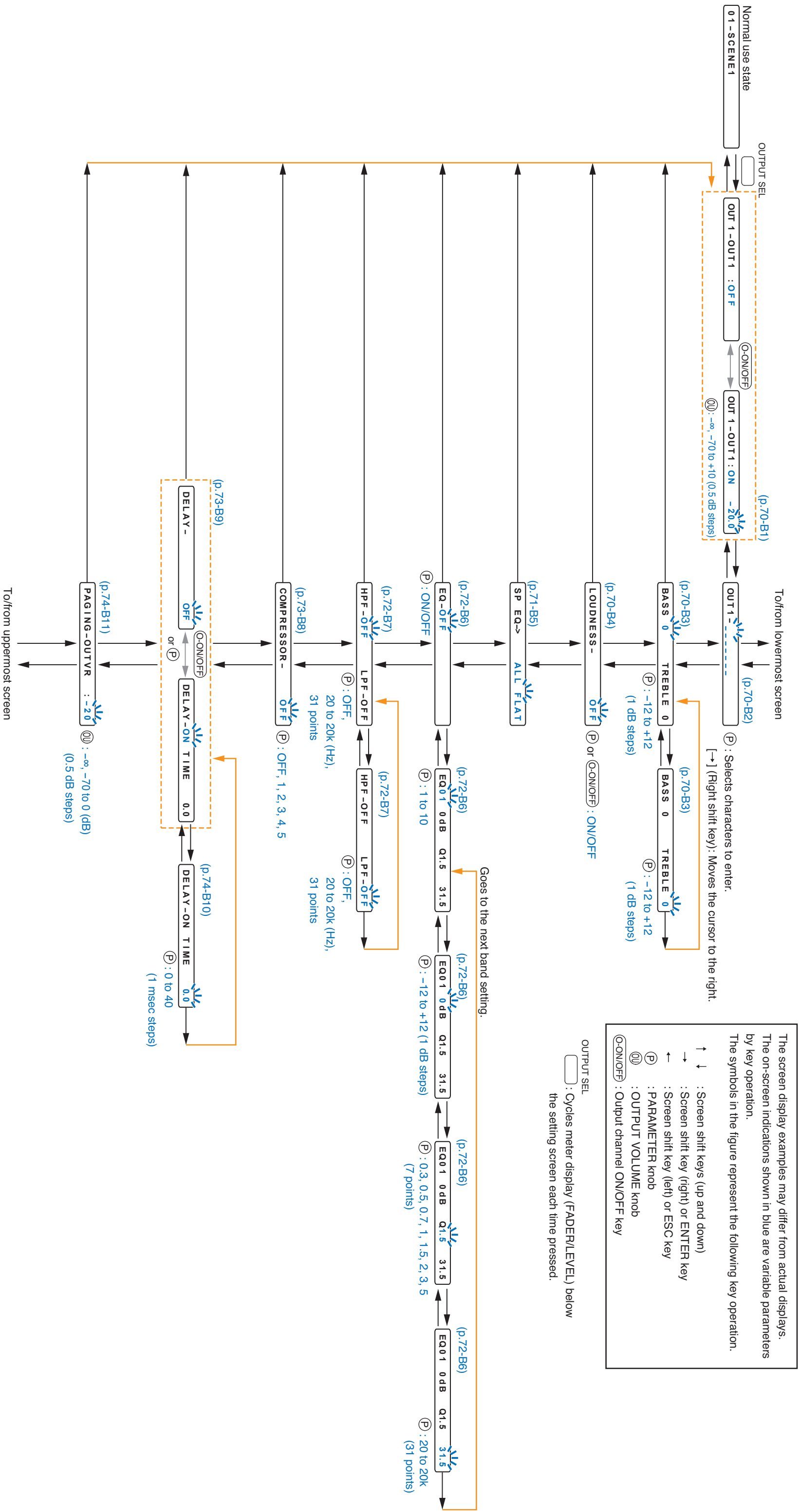

10.3.1. Output setting items

Unless otherwise specified, use the Parameter setting knob for each parameter selection.

(B1) Output gain setting

OUT 1 – OUT 1 : ON - 20.0

Select the output channel using the Output channel selection key.
 Confirm the selection by setting the Output channel ON/OFF key to ON.
 Set the output channel gain using the Output volume control.

Setting Range	Output Channel	OUT1 – 2, Max.8 when T-001Ts are used (default: OUT1)
	Channel Control	ON (default), OFF
	Channel Gain	$-\infty$, -70.0 dB to +10.0 dB (default: -20.0 dB), 0.5 dB steps

(B2) Output channel name setting

OUT 1 – _ _ _ _ _

The flashing portion is the cursor position for entering channel name characters.
 Select a character from the alphanumeric character list by rotating the Parameter setting knob, then move the cursor with the Right shift key.
 Entering a new name overwrites the existing name, if there is.
 To delete the character, select [_] (under-bar) with the Parameter setting knob. A space character cannot be entered.
 Up to 7 characters can be used to set the name.
 Even when an output channel name has been set, some setting screens display the channel number, not the set name.
 When the output channel is stereo-linked (p. 78-C1), the name entry screen only for the odd channel is displayed.

Setting Range	7 characters (default setting: OUT1 – 8)
---------------	--

(B3) BASS and TREBLE settings

BASS 0 TREBLE 0

Rotate the Parameter setting knob to set gains.
 Press the Right or Left shift key to select BASS or TREBLE, of which gain value that flashes can be adjusted.

Setting Range	-12 dB to +12 dB (default: 0 dB), 1 dB steps
---------------	--

(B4) Loudness compensation setting

LOUDNESS – OFF

Rotate the Parameter setting knob to set the loudness compensation function ON/OFF.
 Setting ON boosts low frequencies.

Setting Range	ON, OFF (default)
---------------	-------------------

(B5) Speaker parameter presetting

SP EQ-> ALL FLAT

Optimum equalization can be automatically set depending on the type of speaker to be used. Speaker models (with their parameters) cannot be selected until written into the amplifier using the separate PC software. Up to 10 kinds of speaker models among those listed below can be written into the amplifier. (For details, refer to the separate setting software instruction manual.) If this function is not used or the speaker to be used is not included in a speaker list, set "SP EQ" to ALL FLAT. When the speaker type is selected from the speaker list, the number of bands that can be set on the next EQ setting screen decreases by the number of bands to be used in the setting performed on this screen. The number of bands to be used differs depending on the type of speaker. To perform this setting, select the speaker model from the speaker list and press the Enter key to confirm.

Setting Range	ALL FLAT (default), F-122, F-122 LOWCUT, H-1, H-1 LOWCUT, H-2, H-2 LOWCUT, H-3, H-3 LOWCUT, HB-1, FB-100, SW FOR F-122 (subwoofer for F-122), SR-S4, HX-5, HX-5_E LOWCUT, FB-120, F-1522, F-2322, F-2352, F-2852, SR-H2S, SR-H2L, SR-H3S, SR-H3L, HS-120, HS-150, HS-1200, HS-1500, F-1000 LOWCUT, F-1300 LOWCUT, F-2000 LOWCUT
---------------	---

Note
Settings for the speaker models with LOWCUT indications provide parameters when these speakers are used in conjunction with subwoofers, presenting low-cut characteristics.

[Speaker EQ settings]

	ALL FLAT (Default)		
	GAIN (dB)	FREQ (Hz)	Q
EQ 01	0	31.5	1.5
EQ 02	0	63	1.5
EQ 03	0	125	1.5
EQ 04	0	250	1.5
EQ 05	0	500	1.5
EQ 06	0	1 k	1.5
EQ 07	0	2 k	1.5
EQ 08	0	5 k	1.5
EQ 09	0	8 k	1.5
EQ 10	0	16 k	1.5

Note
For each speaker's parameter, refer to p. 138, "Speaker preset parameter list."

(B6) EQ ON/OFF, Band number, Gain, Q, and Center frequency settings

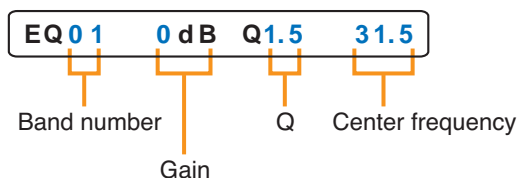

The indications on the right of "EQ" turn on and off as the Parameter setting knob is rotated. When the indication is displayed, EQ is ON and a band number, gain, Q, and center frequency are displayed in this order from left to right. Use the Parameter setting knob to change each parameter, and the Left and Right keys to move the setting items.

Setting Range	EQ	ON, OFF (default)
	EQ Band Number	01 to 10 (default: 01)
	Gain	-12 dB to +12 dB (default: 0 dB), 1 dB steps
	Q	0.3, 0.5, 0.7, 1, 1.5 (default), 2, 3, 5
	Center Frequency	20, 25, 31.5 (default), 40, 50, 63, 80, 100, 125, 160, 200, 250, 315, 400, 500, 630, 800, 1 k, 1.25 k, 1.6 k, 2 k, 2.5 k, 3.15 k, 4 k, 5 k, 6.3 k, 8 k, 10 k, 12.5 k, 16 k, 20 kHz

(B7) HPF and LPF settings



Rotate the Parameter setting knob to set the cut-off frequencies. Press the Right or Left shift key to select HPF or LPF, of which parameter that flashes can be adjusted.

Setting Range	HPF	OFF (default), 20, 25, 31.5, 40, 50, 63, 80, 100, 125, 160, 200, 250, 315, 400, 500, 630, 800, 1 k, 1.25 k, 1.6 k, 2 k, 2.5 k, 3.15 k, 4 k, 5 k, 6.3 k, 8 k, 10 k, 12.5 k, 16 k, 20 kHz
	LPF	

(B8) Compressor setting

COMPRESSOR – OFF

Setting Range	OFF (default), 1, 2, 3, 4, 5
---------------	------------------------------

Use the compressor to prevent power amplifier overload or to produce more easily heard sound by averaging the audio level. The number shows the compressor's effectiveness level as shown in the table below, which can be set by rotating the Parameter setting knob.

- DEPTH = 1 (Peak limiter)
Provides a peak limiter function that protects amplifiers and speakers against damage caused by an excessive signal input.
This level is suited to speech applications.
- DEPTH = 2 (Peak limiter)
Provides a peak limiter function that protects amplifiers and speakers against damage caused by an excessive signal input.
This level is suited to musical applications.
- DEPTH = 3 (Sonic normalizer)
Equalizes the sound volume of reproduced BGM among CDs or pieces of music by boosting small sounds and lowering big sounds, making the entire sound volume uniform.
This level is suited to BGM reproduction.
- DEPTH = 4 (Speech leveler)
Makes paging calls easier to hear by equalizing the difference in speech signal volume that may result from individual differences in speaker voice volumes or variations in speaker-to-microphone distances.
Since the volume is extensively corrected, the feedback margin narrows, making it liable to occurrences of feedback. Therefore, special care must be taken when installing microphones and speakers.
This level is suited to microphone speech applications.
- DEPTH = 5 (Speech leveler)
Makes paging calls easier to hear by equalizing the difference in speech signal volume that may result from individual differences in speaker voice volumes or variations in speaker-to-microphone distances.
This level 5 is more effective than level 4. Since the volume is extensively corrected, the feedback margin narrows, making it liable to occurrences of feedback. Therefore, special care must be taken when installing microphones and speakers.
This level is suited to microphone speech applications.

Parameter	DEPTH = 1	DEPTH = 2	DEPTH = 3	DEPTH = 4	DEPTH = 5
Threshold 1	-20 dB	-20 dB	-30 dB	-78 dB	-78 dB
Threshold 2	-10 dB	-10 dB	-25 dB	-30 dB	-30 dB
Ratio 1	1 : 1	1 : 1	1 : 1	1 : 2	1 : 2.6
Ratio 2	2 : 1	2 : 1	1.25 : 1	1.25 : 2	2.5 : 1
Ratio 3	20 : 1	20 : 1	5 : 1	8 : 2	20 : 1
Attack time constant	0.1 msec	0.1 msec	0.1 msec	0.1 msec	0.1 msec
Release time constant	100 msec	1 msec	5 msec	100 msec	100 msec
COMP. output level	0 dB	0 dB	0 dB	+12 dB	+24 dB

Note: For the compression characteristics diagram, refer to [p. 137](#).

(B9) Delay ON/OFF setting

DELAY – OFF

Set the delay function to ON or OFF.
When ON, the delay time setting follows.

Setting Range	ON, OFF (default)
---------------	-------------------

- ON: The delay function works.
- OFF: The delay function does not work.

(Only when the delay function is set to ON)

(B10) Delay time setting

DELAY-ON TIME 0.0

Set the delay time.

Setting Range	0 – 40 ms (default: 0), 1 ms steps Note Maximum 40 ms total of time for Output channels 1 and 2. When the T-001T is used, maximum 40 ms total of time for each pair of Output channels 3 and 4, 5 and 6, and 7 and 8.
---------------	---

Delay time can be adjusted to up to 40 ms in total for the amplifier's Output channels 1 and 2, and for the paired output channel when the T-001T is used.

For example, when the delay time for Output channel 1 is set to "30," set that for Output channel 2 to "10" or less. If the delay time for Output channel 2 is set to over "10," that for Output channel 1 is automatically adjusted so that the total delay time for both channels becomes 40.

(B11) Paging output volume setting

PAGING-OUTVR : 0

When the selected input channel is set for paging use, sets the output gain.

This set value is saved separately from that for scene memory, so that the paging output level is constant even when any scene is recalled.

Setting Range	$-\infty$, -70 to 0 dB (default: -20 dB), 0.5 dB steps
---------------	---

10.4. UTILITY Setting Flow Chart

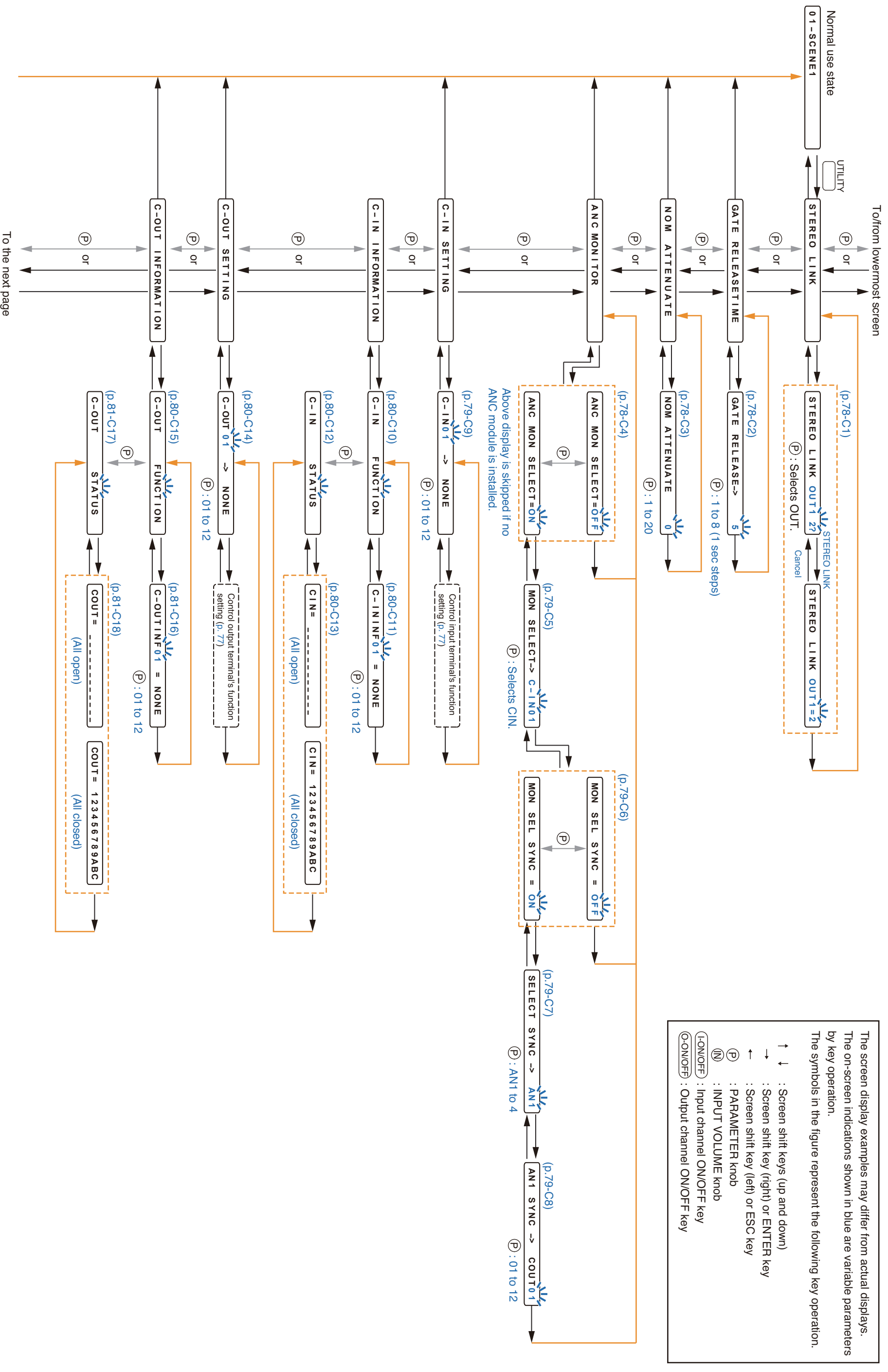

From the previous page

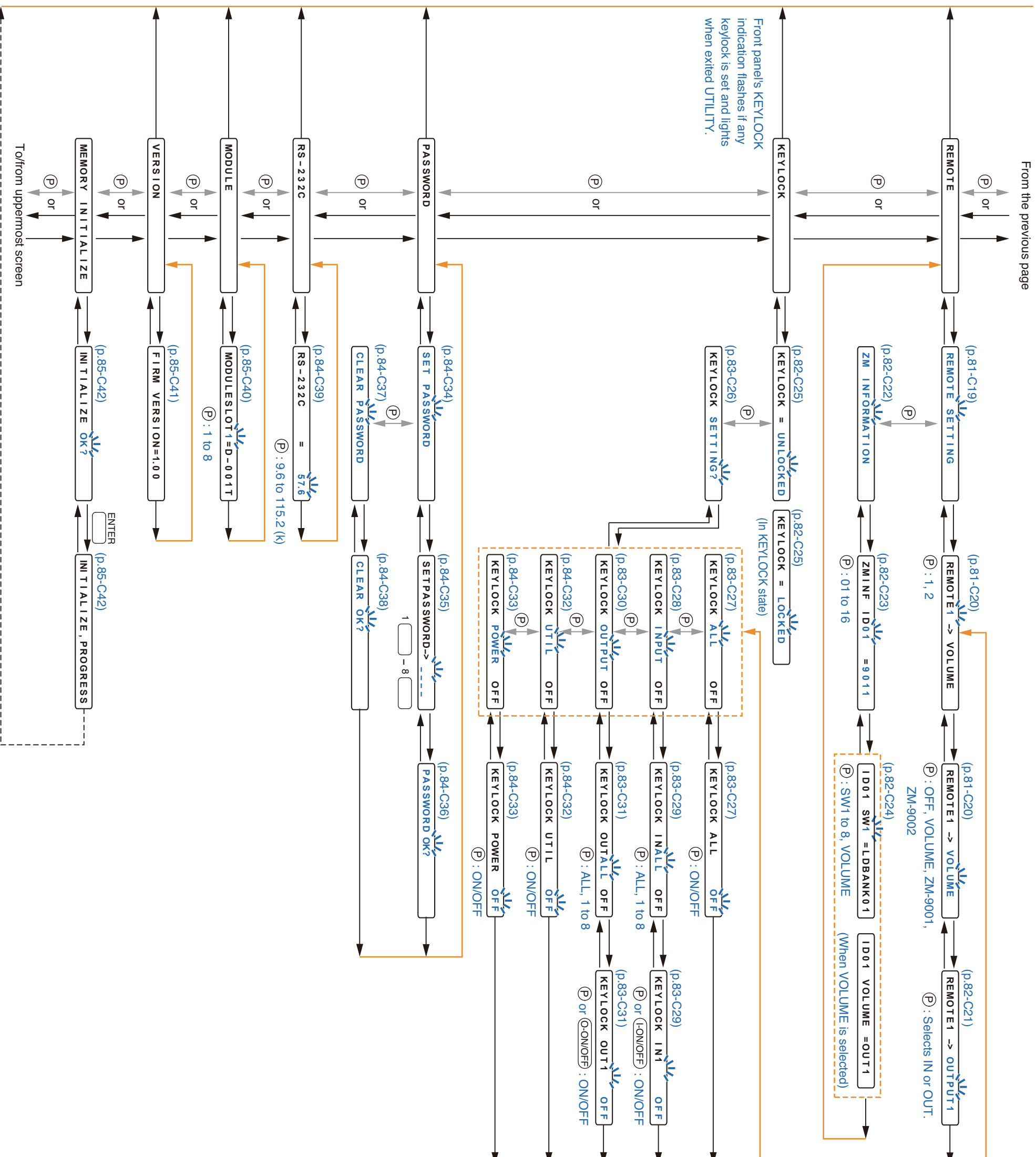

10.4.3. Utility setting items

Unless otherwise specified, use the Parameter setting knob for each parameter selection.

(C1) Stereo link setting

STEREO LINK OUT 1 = 2

Set a paired input or output channel as stereo input or stereo output so that both channels can be synchronously operated. Select a channel pair with the Parameter setting knob, and determine it with the Enter key. Pressing the Enter key again cancels this setting. By repeating this procedure, up to 8 channels (4 pairs) each for input and output can be set when the number of input and output channels is maximum. When the paired channel is stereo-linked, an equal mark "=" appears between both channel numbers. Parameter settings for the stereo-linked channels synchronize. Parameters that can be synchronized are as follows:

- Input channel: Channel gain, Channel ON/OFF, and D-001T's parameters (where Phantom power and NOM attenuation function are fixed to OFF)
- Output channel: Channel gain, Channel ON/OFF, Channel name, Bass, Treble, Loudness compensation, EQ, HPF, LPF, Compressor, Delay, and T-001T's parameters (where Phantom power and NOM attenuation function are fixed to OFF)

Setting Range	Default: No channel is stereo-linked. Note The ZP-001T channel cannot be stereo-linked. Up to 8 channels (4 pairs) each for input and output can be set as follows when the number of input and output channels is maximum: OUT 1 – 2, OUT 3 – 4, OUT 5 – 6, OUT 7 – 8, IN 1 – 2, IN 3 – 4, IN 5 – 6, and IN 7 – 8
---------------	---

(C2) GATE release time setting

GATE RELEASE-> 5

Sets the time (seconds) required for the muted signal to return to the original level after the GATE activating input signal decreases below the threshold level.

Setting Range	1 – 8 (default: 5)
---------------	--------------------

(C3) NOM attenuation setting

NOM ATTENUATE 0

Set the amount of NOM (Number of Open Microphones) attenuation. The NOM attenuation function automatically reduces an output gain to prevent the entire volume from being excessively raised due to open microphones. When the value to be set here is A and the number of open microphones is N, the attenuation gain is given by the following equation:

$$\text{Attenuation gain} = A \times \log_{10}N$$

This function is valid only for the D-001T's input channels having the NOM attenuation function.

Setting Range	0 – 20 (default: 0)
---------------	---------------------

(C4) ANC monitor switching ON/OFF setting

ANC MON SELECT = ON

If there are 2 or more ANC inputs, set whether or not ANC inputs to be monitored are switched.

Setting Range	OFF (default), ON
---------------	-------------------

(C5) Monitor switching control input terminal setting (When the ANC monitor switching is set to ON)

MON SELECT-> C-IN01

Select the control input terminal to switch the ANC inputs* to be monitored.
Selecting the terminal overwrites the previously set function on it if there is.

Setting Range	C-IN01 – 04, CIN01 – 12 when C-001T is used (default: C-IN01)
---------------	---

Each time the designated terminal is closed, the ANC inputs to be monitored are switched in numerical order from ANC input 1.

* ANC inputs are the input channels of AN-001T Ambient Noise Sensor Input module. One AN-001T module has 2 input channels. When 2 AN-001T modules are mounted, the AN-001T's inputs in the slot with smaller number correspond to ANC Input channels 1 and 2, and another's inputs in another slot to ANC Input channels 3 and 4.

(C6) Interlock output control setting (When the ANC monitor switching is set to ON)

MON SEL SYNC = ON

Perform ON/OFF setting for the function that closes the control output terminal in synchronization with the control input terminal closure of the set number.

Setting Range	OFF (default), ON
---------------	-------------------

**(C7) Monitored ANC input channel selection
(When the ANC monitor switching is set to ON, and the interlock output control to ON)**

SELECT SYNC -> AN1

Select the ANC input channel. Each channel for which the monitor function is set to ON can be selected.

Setting Range	ANC 1 – 4 (Only ANC input channels for which the monitor function is ON)
---------------	--

**(C8) Interlock output terminal setting
(When the ANC monitor switching is set to ON, and the interlock output control to ON)**

AN1 SYNC -> COUT01

Set the control output terminal which is closed in synchronization with switching to the monitored ANC input channel.
Assigning the function to this terminal overwrites the previously set function on it if there is.

Setting Range	COUT01 – 04, COUT01 – 12 when C-001T is used (default: COUT01)
---------------	--

(C9) Control input terminal number selection

C-IN01 -> NONE

Setting Range	C-IN01 – 04 (C-IN01 – 12 when C-001T is used), ZM-IN01 – 12* (default: C-IN01) * Selectable only when the Remote controller type (p. 81-C20) is set to ZM-9001 or ZM-9002.
---------------	---

Set the control input terminal number to be assigned to the control input function.
The screen indications ZM-IN01 – 06 or 01 – 04 correspond to the control buttons of the ZM-9001 or ZM-9002 connected to the 9000M2 Series amplifier's remote volume control terminal 1 (REMT VOL 1). The indications of ZM-IN with subsequent numbers correspond to ZM-9001's or ZM-9002's control buttons connected to the remote volume control terminal 2 (REMT VOL 2).
To set a terminal number, refer to p. 77 for the flow chart of the control input function setting.

(C10) Control input terminal setting information

C- IN FUNCTION

When FUNCTION is selected, functions assigned to the control input terminals are displayed on the screen.

(C11) Control input terminal function display

C- IN INF 01 = NONE

Displays the function assigned to the control input terminal.

The screen indications represent the following functions:

- NONE: No function is assigned.
- PG TRIG: Paging activation
- LOADSCENE: Scene memory recall
- VOLUP: Volume up
- VOLDOWN: Volume down
- CH ON: Channel ON
- CH MUTE: Channel mute
- EMG MUTE: Emergency mute activation (All output channel mute)
- POWER: Power ON

(C12) Control input terminal status information

C- IN STATUS

When STATUS is selected, current control input terminal statuses are displayed on the screen.

(C13) Control input terminal status display (when all are open)

C I N = _ _ _ _ _

(C13) Control input terminal status display (when all are closed)

C I N = 1 2 3 4 5 6 7 8 9 A B C

Status of all control input terminals can be confirmed on the screen, with the terminal Nos. 1 – 12 arranged in numerical order from left to right.

When closed, the terminal number is indicated by alpha-numerals. Alphabet A represents the terminal number 10, B represents 11, and C represents 12.

An open terminal is indicated by an underscore "_".

(C14) Control output terminal number selection

C- OUT 01 -> NONE

Setting Range	C-IN01 – 04, C-IN01 – 12 when C-001T is used
---------------	--

Set the control output terminal number to be assigned to the control output function.

To set a terminal number, refer to p. 77 for the flow chart of the control output function setting.

Note: The control output terminal having the function of CH MUTE (Channel mute), EMG MUTE (Emergency mute, or all output channel mute), or PG OUT (Paging activation) is represented as "NONE" on the screen.

(C15) Control output terminal setting information

C- OUT FUNCTION

When FUNCTION is selected, functions assigned to the control output terminals are displayed on the screen.

(C16) Control output terminal function display

C-OUT INF 01 = NONE

Displays the function assigned to the control output terminal.
The screen indications represent the following functions:

- NONE: No function is assigned.
- POWER: Power ON
- LD SCENE: Scene memory recall
- CH ON: Channel ON
- CH MUTE: Channel mute
- EMG MUTE: Emergency mute activation (All output channel mute)
- PG OUT: Paging activation

(C17) Control output terminal status information

C-OUT STATUS

When STATUS is selected, current control output terminal statuses are displayed on the screen.

(C18) Control output terminal status display (when all are open)

COUT = _ _ _ _ _

(C18) Control output terminal status display (when all are closed)

COUT = 1 2 3 4 5 6 7 8 9 ABC

Status of all control output terminals can be confirmed on the screen, with the terminal Nos. 1 – 12 arranged in numerical order from left to right.
When closed, the terminal number is indicated by alpha-numerals. Alphabet A represents the terminal number 10, B represents 11, and C represents 12.
An open terminal is indicated by an underscore "_".

(C19) Remote control input terminal setting

REMOTE SETTING

Sets functions assigned to the remote control terminals (REMT VOL1 and REMT VOL2).

(C20) Remote controller type setting

REMOTE 1 -> VOLUME

Set the type of remote controller connected to the remote control input terminals.
Use the Left and Right shift keys to move the setting items on the screen.

Setting Range	Remote Volume Terminal Number	REMOTE 1, REMOTE 2
	Controller type	OFF (default), VOLUME, ZM-9001, ZM-9002

- OFF: Select this setting when no remote controller is connected.
- VOLUME: Select this setting when a normal variable resistor or variable DC power supply unit is connected.
- ZM-9001: Select this setting when the ZM-9001 is connected. This setting adds 6 control inputs. These inputs are assigned the functions in the setting screen on [p. 85-C43](#).
- ZM-9002: Select this setting when the ZM-9002 is connected. This setting adds 4 control inputs and 1 remote volume control. These inputs are assigned the functions in the setting screens on [p. 85-C43](#).

(C21) Remote-controlled channel setting
(when the remote controller type is set to VOLUME or ZM-9002)

REMOTE 1 -> OUTPUT 1

Select the input or output channel of which volume you want to remotely control by using the control input terminals on the rear panel or ZM-9002's volume control.
 The REMOTE 1 on the screen represents the REMT VOL 1 of control input terminal, and the REMOTE 2 represents the REMT VOL 2.
 Use the Left and Right shift keys to move the setting items on the screen.

Setting Range	Remote Volume Terminal Number	REMOTE 1, REMOTE 2
	Remote-controlled channel	OFF, INPUT 1 – 8, OUTPUT 1 – 2, Max. OUTPUT 8 when T-001Ts are used (default for REMOTE 1: OUTPUT 1, REMOTE 2: OUTPUT 2)

(C22) Communication type remote controller setting information

ZM INFORMATION

Displays the setting of the ZM-9011/9012/9013/9014 Wall-mounted remote controller of data communication type.

Note: This setting is made only by the supplied PC software.

(C23) Communication type remote controller ID/model number information

ZMINF ID01 = 9011

Displays the connected remote controller and its ID number.

Note: This setting is made only by the supplied PC software.

(C24) Communication type remote controller function information

ID01 SW1 = LDBANK01

ID01 VOLUME = OUT1

Displays the functions assigned to the buttons and/or volume control on the remote controller.
 When the connected controller is ZM-9012 or ZM-9014 with a volume control, the output channel indicator of the channel on the VFD lights to indicate that channel is assigned to the volume control.
 The output channel selection indicator of the channel to be displayed by the level indicator flashes.

(C25) Lock status display

KEYLOCK = UNLOCKED

Setting Range	UNLOCKED (default), LOCKED
---------------	----------------------------

The above screen displays the current key lock status.
 When a key other than the Utility key is locked, "UNLOCKED" is indicated. If a locked key is pressed, the display changes to the password entry screen. To enter the key lock setting flow, press the Enter key.

(C26) Key lock setting

KEYLOCK SETTING?

Confirmation screen to enter the key lock setting.

Press the Enter key or Right Shift key to perform the key lock setting.

(C27) All-key lock ON/OFF

KEYLOCK ALL OFF

Selecting ON locks all keys located on the front panel.

If ON/OFF settings differ from key to key, the [- -] indication is displayed when this screen appears.

(C28) Input key lock ON/OFF

KEYLOCK INPUT OFF

Selection ON locks all Input channel selection keys, Input channel ON/OFF key, and Input volume control.

If ON/OFF settings differ from channel to channel, the [- -] indication is displayed when this screen appears.

(C29) Input channel selection key lock ON/OFF

KEYLOCK INALL OFF

Locks the Input channel selection key, Input channel ON/OFF key, and Input volume control for each input channel.

Select with the Parameter setting knob the input channel to be locked, and set the key lock function to ON with the Input channel ON/OFF key.

(C30) Output key lock ON/OFF

KEYLOCK OUTPUT OFF

Locks all Output channel selection keys, Output channel ON/OFF key, and Output volume control.

If ON/OFF settings differ from channel to channel, the [- -] indication is displayed when this screen appears.

(C31) Output channel selection key lock ON/OFF

KEYLOCK OUTALL OFF

Locks the Output channel selection key, Output channel ON/OFF key, and Output volume control for each Output channel.

Select with the Parameter setting knob the Output channel to be locked, and set the key lock function to ON with the Output channel ON/OFF key.

The Output channel selection key selects an output channel one by one only in numerical order starting from Channel 1. So, when the output channel selection key is locked at an output channel, the subsequent output channels cannot be used unless the locked key is unlocked at the channel by entering a password.

(C32) Setting key lock ON/OFF

KEYLOCK UTIL OFF

Selecting ON locks Utility key, Memory key, Enter key, Escape/Back key, and Parameter setting knob.

(C33) Power switch lock ON/OFF

KEYLOCK POWER OFF

Selection ON locks the Power switch.

Setting this function disables the power switch to be turned off when the unit's power is on. (Power can be turned on whenever the unit is off irrespective of the power switch lock ON/OFF status.)

To power off the unit, perform the remote control or turn the power switch off in the normal operation mode after setting the power switch lock function to OFF here and exiting the function setting mode.

(C34) Password setting

SET PASSWORD

Sets or deletes the password.

To set the password, press the Enter key at the password setting screen to proceed the setting.

To delete the set password, press the Enter key at the password deletion screen, and the confirmation screen is displayed.

(C37) Password deletion

CLEAR PASSWORD

(C35) Password setting

SET PASSWORD-> _ _ _ _

Passwords can be set only when the keys are not locked.

Use the Input channel selection key to set the password and use the Left and Right shift keys to move between characters. For password setting procedure, refer to [p. 91 "Password setting."](#)

(C36) Password setting confirmation

PASSWORD OK?

Confirmation screen to set the password.

Pressing the Enter key sets the password.

(C38) Password deletion confirmation

CLEAR OK?

Confirmation screen to delete the set password.

Pressing the Enter key deletes the password.

(C39) Communication speed (bps) setting

RS - 2 3 2 C = 57.6

Setting Range	9.6 k, 19.2 k, 38.4 k, 57.6 k (default), 115.2 k
---------------	--

(C40) Slot number selection and 900 series module classification setting

MODULESLOT 1 = D - 0 0 1 T

Setting Range	Slot Number	1 – 8 (default: 1)
	Module Classification	OTHERS (default), B-01, B-11, B-21, B-41, E-03, E-04, E-05, E-06, E-07, L-01, L-11, L-41, M-01, M-03, M-11, M-21, M-41, M-51, M-61, S-01, S-02, S-04, S-20S, T-01, T-02, T-12, U-01, U-03, U-11, U-12, U-13, U-14, U-21, U-43, U-61, V-01, ML-11T, NONE

Use the Left and Right shift keys to move the setting items on the screen.

For slots equipped with 9000 Series plug-in modules, their module model numbers are automatically displayed and cannot be changed. For slots equipped with 900 Series input modules, select their model numbers using the Parameter setting knob.

The settings performed here are merely displayed, and have no effect on the audio input and other settings. Setting the open slot to NONE extinguishes the indicators of the corresponding Input channel and its subsequent channels on the front panel. Besides, the channels do not appear on any setting screen.

(C41) Firmware version indication

F I R M V E R S I O N = 1 . 0 0

Displays the firmware version number.

(C42) Memory initialization

INITIALIZE OK?

Pressing the Enter key initializes all of the unit's current settings to the factory default setting.

(C42) Memory initialization

INITIALIZE , PROGRESS

(C43) Control input function setting

C - I N 0 1 -> N O N E

Setting Range	C-IN01 to 12: NONE (default), LOADSCENE (Scene memory recall), VOLUP (volume up), VOLDDOWN (volume down), CH ON (channel ON), CH MUTE (channel mute), EMG-MUTE (Cut-off by Emergency control), POWER (Power ON/OFF remote control), PG DISABLE (Paging disable)
	ZM-IN01 to 12: NONE (default), LOADSCENE, VOLUP, VOLDDOWN

Sets the functions to be assigned to the control input terminals or control buttons of the ZM-9001 or ZM-9002.

[When the function is set to LOADSCENE]

(C44)

(When the control input function is set to LOADSCENE)

C - I N 0 1 -> L O A D S C E N E

Closing the control input terminal recalls the settings saved in a Scene memory bank number.

Assigning a function to the control input terminal or ZM-9001/9002's control button overwrites the previously set function on it if there is.

(C45) Scene memory bank number selection

C - I N 0 1 - L O A D S C E N E 0 1

Select the bank number to recall.

Setting Range	01 – 32 (default: 01)
---------------	-----------------------

[When the function is set to VOLUP or VOLDDOWN]

(C46)
(When the control input function is set to VOLUP)

C - IN 0 1 -> VOLUP

(C47)
(When the control input function is set to VOLDDOWN)

C - IN 0 1 -> VOLDDOWN

Assign the volume-up or volume-down function to the control input.
Closing the control input terminal increases or decreases the volume of the set input or output channel.
Assigning a function to the control input terminal or ZM-9001/9002's control button overwrites the previously set function on it if there is.

(C48)
Input/Output channel number selection
(VOLUP)

C - IN 0 1 - VOLUP-> IN 1

(C49)
Input/Output channel number selection
(VOLDDOWN)

C - IN 0 1 - VOLDDOWN-> IN 1

Using the Input channel or Output channel selection key, select the channel number for which you want to change the volume.
One control input can change one input or output channel volume.
You can change the sound volume for a channel even with the channel off, but not adjust it while monitoring the sound.

Setting Range	IN1 - 8, OUT1 - 2, Max. OUT8 when T-001Ts are used (default: IN1)
---------------	---

(C50) Volume increasing level setting

C - IN 0 1 - VOLUP 0.5

(C51) Volume decreasing level setting

C - IN 0 1 - VOLDDOWN 0.5

Set the volume level (dB) to increase or decrease.

Setting Range	0.5 - 10.0 dB (default: 0.5)
---------------	------------------------------

[When the function is set to CH ON]

(C52)
(When the control input function is set to CH ON)

C - IN 0 1 -> CH ON

Assign the function to turn on the designated input or output channel to the control input terminal.
Closing the set control input terminal turns on the designated input or output channel.
Assigning a function to this terminal overwrites the previously set function on it if there is.

(C53) Input/Output channel number selection

C - IN 0 1 - CH ON-> IN 1

Select with the input or output channel selection key the input or output channel to turn ON.
One control input can turn on one input or output channel.

Setting Range	IN1 - 8, OUT1 - 2, Max. OUT8 when T-001Ts are used (default: IN1)
---------------	---

[When the function is set to CH MUTE]

(C54)

(When the control input function is set to CH MUTE)

C- I N 0 1 -> CH MUTE

Assign the function that mutes the input or output channel to the control input.

Closing the control input terminal mutes the set channel.

Assigning a function to this terminal overwrites the previously set function on it if there is.

(C55) Input/Output channel number selection

C- I N 0 1 - CH MUTE->I N 1

Using the Input channel or Output channel selection key, select the channel number to be muted.

One control input can mute one input or output channel.

Setting Range	IN1 – 8, OUT1 – 2, Max. OUT8 when T-001Ts are used (default: IN1)
---------------	---

(C56) Interlock output control setting

C- I N 0 1 -SYNC OFF

Perform ON/OFF setting for the function that closes the control output terminal in synchronization with the control input terminal closure of the set number.

Setting Range	ON, OFF (default)
---------------	-------------------

(When the interlock output control is set to ON)

(C57) Interlock output terminal setting

C- I N 0 1 - C - OUT 0 1

This screen is displayed only when the interlock output control is set to ON.

Set the control output terminal which is closed in synchronization with the control input of the set number.

Assigning a function to this terminal overwrites the previously set function on it if there is.

Setting Range	C-OUT01 – 04, C-OUT01 – 12 when C-001T is used (default: C-OUT01) Note: When the interlock output control ON/OFF setting is ON.
---------------	---

[When the function is set to EMG MUTE]

(C58)

(When the control input function is set to EMG MUTE)

C- I N 0 1 -> ENG MUTE

Assign the function that simultaneously mutes all output channels to the control input. Closing the control input terminal mutes all output channels.

This function is used to mute the output provided from the unit during emergency broadcast operation.

Assigning a function to this terminal overwrites the previously set function on it if there is.

(C59) Interlock output control setting

C- I N 0 1 -SYNC OFF

Perform ON/OFF setting for the function that closes the control output terminal in synchronization with the control input terminal closure of the set number.

Setting Range	ON, OFF (default)
---------------	-------------------

(When the interlock output control is set to ON)

(C60) Interlock output terminal setting

C- I N 0 1 - C - O U T 0 1

This screen is displayed only when the interlock output control setting is set to ON.
Set the control output terminal which is closed in synchronization with the control input of the set number.
Assigning a function to this terminal overwrites the previously set function on it if there is.

Setting Range	C-OUT01 – 04, C-OUT01 – 12 when C-001T is used (default: C-OUT01) Note: When the interlock output control ON/OFF setting is ON.
---------------	---

[When the function is set to POWER]

(C61)

(When the control input function is set to POWER)

C- I N 0 1 -> P O W E R

Assign the power ON or OFF function to the control input terminal.
Closing the set control input turns the power ON, and then opening it turns the power OFF.
Assigning a function to this terminal overwrites the previously set function on it if there is.

(C62) Paging prohibition setting

C- I N 0 1 ->P G D I S A B L E

Sets the control input to disable paging.

(C63) Paging prohibited output setting

C I N 0 1 - D I S A B L E->O U T 1

Sets the output to prohibit paging.
When the control input is closed during paging, paging to the set output channel is interrupted.

Setting Range	OUT1 - 8
---------------	----------

(C64) Control output function setting

C- O U T 0 1 -> N O N E

Select the function assigned to the control output terminal.

Setting Range	NONE (default), POWER (Power ON/OFF remote control), SCENE (Scene memory recall), CH ON (channel ON)
---------------	--

[When the function is set to POWER]

(C65)

(When the control output function is set to POWER)

C- O U T 0 1 -> P O W E R

Provides a Level output when the power is turned on.
Assigning a function to this terminal overwrites the previously set function on it if there is.

[When the function is set to SCENE]

(C66)

(When the control output function is set to SCENE)

C-OUT 01 -> LD SCENE

Provides a Level output when a Scene memory is recalled.

Assigning a function to this terminal overwrites the previously set function on it if there is.

(C67) Scene memory bank number selection

C-OUT 01 - LD SCENE 01

Select the Scene memory bank number that causes the selected control output terminal to provide a Level output when the Scene memory is recalled.

Setting Range	01 -32 (default: 01)
---------------	----------------------

[When the function is set to CH ON]

(C68)

(When the control output function is set to CH ON)

C-OUT 01 -> CH ON

Provides a Level output when the input or output channel becomes on.

Assigning a function to this terminal overwrites the previously set function on it if there is.

(C69) Input/Output channel number selection

C-OUT 01 - CH ON-> IN1

Select the input or output channel number that causes the selected control output terminal to provide a Level output when the channel becomes on.

Setting Range	IN1 – 8, OUT1 – 2, Max. OUT8 when T-001Ts are used (default: IN1)
---------------	---

10.5. Key Lock Function Setting

The key lock function prevents equipment malfunctions by disabling operation of each key.

10.5.1. Keys that can be locked

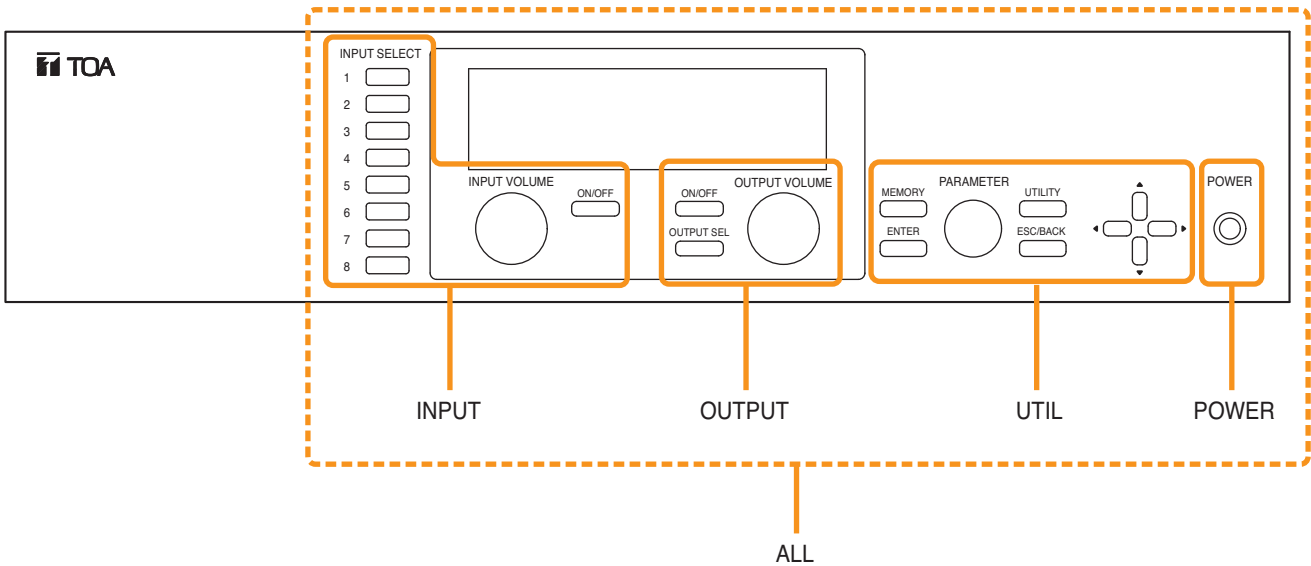

ALL: Locks all keys simultaneously.

INPUT: Locks the Input channel selection keys, Input volume control, and Input channel ON/OFF key. It is also possible to individually set whether or not to lock for each channel.

OUTPUT: Locks the Output channel selection key, Output volume control, and Output channel ON/OFF key. It is also possible to individually set whether or not to lock for each channel.

UTIL: Locks the Utility menu key, Memory key, Enter key, Escape/Back key, and Parameter setting knob.

POWER: Locks the Power switch.

10.5.2. Password setting

When using a password, set the password before performing lock setting for each key.

Step 1. Press the Utility key.
The Utility setting screen is displayed.

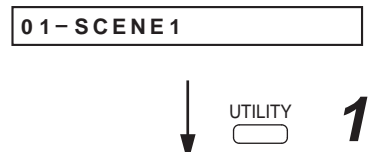

Step 2. Press the Down shift key until the password screen is displayed.

Note
No password is factory-preset.
(The [_ _ _ _] indication is displayed.)

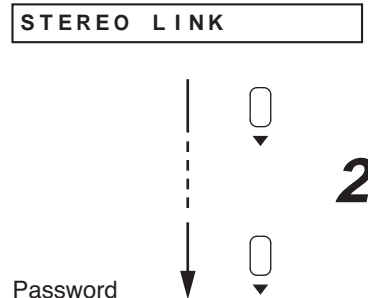

Step 3. Press the Right shift key twice.
The password entry screen is displayed.

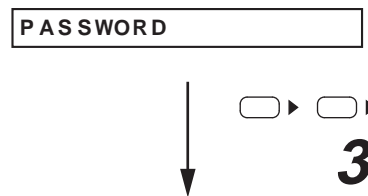

Step 4. Enter a password using the Input channel selection keys (1 – 8).
The position on the extreme left flashes first for character entry.
Entering a character changes the [] indication into [*].
Use up to 4 characters to set the password.

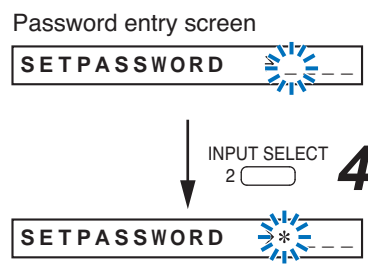

Step 5. Press the Right shift key after setting completion.
The confirmation screen is displayed.

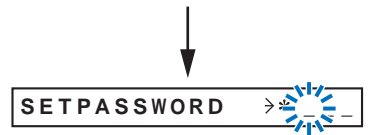

Step 6. Press the Right shift key.
The password setting is completed, and the screen returns to the password screen at Step 2.

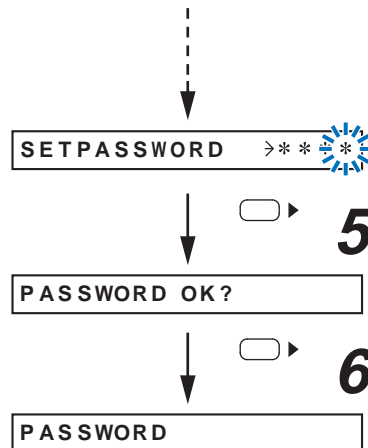

10.5.3. Key lock setting operation

Step 1. Press the Utility key.
The Utility setting screen is displayed.

Step 2. Press the Down shift key until the keylock screen is displayed.

Step 3. Press the Right shift key.
Lock status is displayed.

Step 4. Rotate the Parameter setting knob to display the "KEYLOCK SETTING ?" screen.

Step 5. Press the Right shift key.
The all-key lock ON/OFF setting screen is displayed.

Step 6. Set keys to be locked.

6-1. All-key lock setting
Press the Right shift key to display the "KEYLOCK ALL" ON/OFF screen, then set the function to ON with the Parameter setting knob.

6-2. Selected key(s) lock setting
Rotate the Parameter setting knob to display individual setting screen for each key, and perform the ON/OFF setting with the Right shift key.
The key lock for each input or output channel key can be set to ON or OFF by selecting it on the screen.

Note

The setting flow on the right is an example for locking the input channel 1.

Step 7. Press the Right shift key after setting completion.
The display returns to the all-key lock setting screen.

Step 8. Press the ESC/BACK key.

Step 9. Rotate the Parameter setting knob.

Step 10. Press the Left shift key.
The display returns to the normal use state screen, making the key lock setting valid.

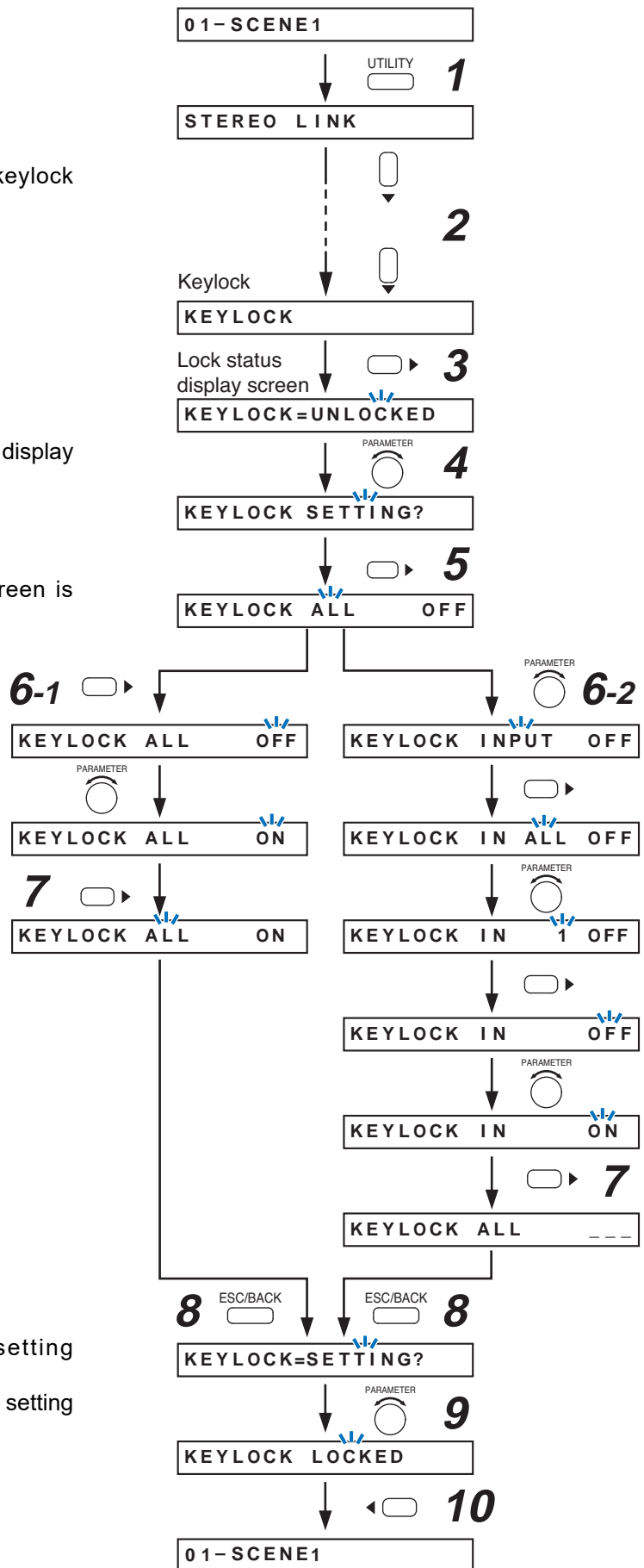

10.6. SCENE MEMORY Setting Flow Chart

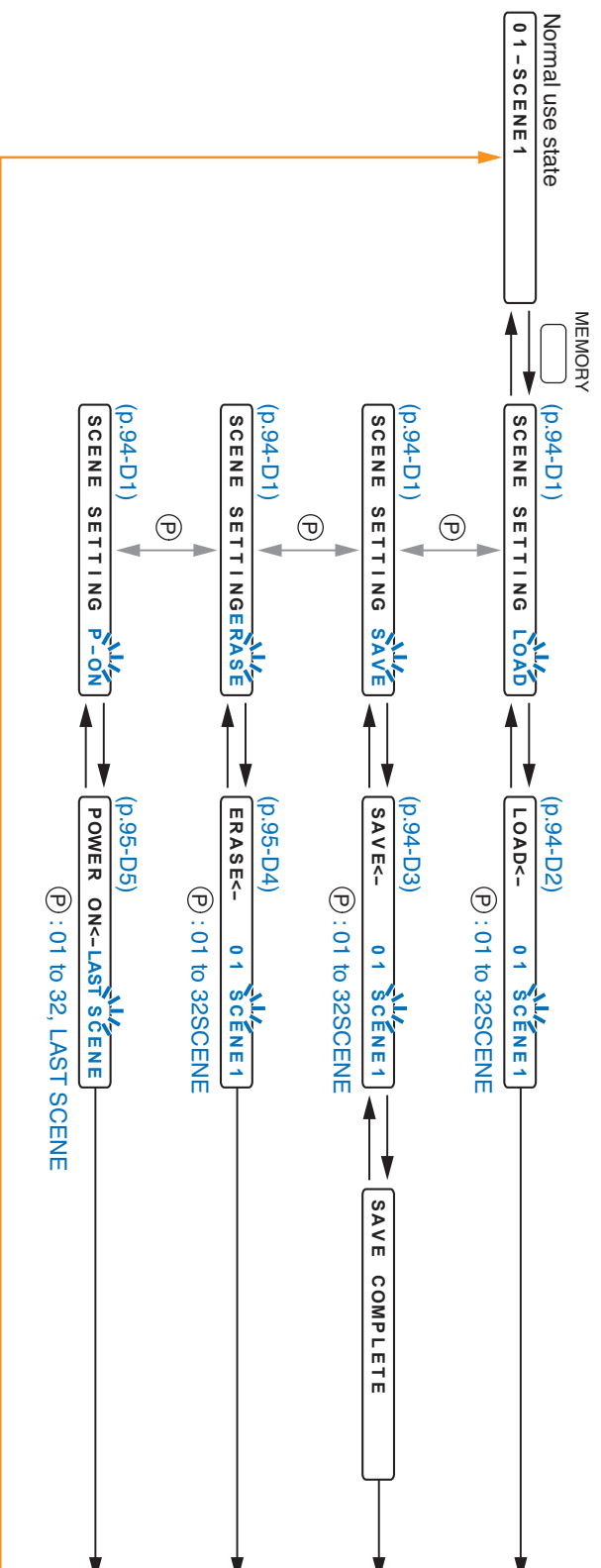

The screen display examples may differ from actual displays.
 The on-screen indications shown in blue are variable parameters by key operation.
 The symbols in the figure represent the following key operation.

- ↑ ↓ : Screen shift keys (up and down)
- : Screen shift key (right) or ENTER key
- ← : Screen shift key (left) or ESC key
- ⊕ : PARAMETER knob

10.6.1. Scene memory setting items

Unless otherwise specified, use the Parameter setting knob for each parameter selection.

(D1) Scene memory setting

SCENE SETTING LOAD

Set the Scene memory function.

Setting Range	LOAD (default), SAVE, ERASE, P-ON
---------------	-----------------------------------

- LOAD: Recalls the saved scene memory.
- SAVE: Saves the current settings as a Scene memory.
- ERASE: Erases the Scene memory.
- P-ON: Sets the Scene memory bank number to be recalled at power-on.

Select the function above and press the Enter key, and the corresponding screen is displayed.

(D2) Scene memory recall

LOAD<- 01 SCENE 1

Designate the Scene memory bank number to recall.

Setting Range	01 – 32 (default: 01)
---------------	-----------------------

Pressing the Enter key recalls the designated Scene memory.

After recall completion, the screen displays the Scene memory bank number and the set memory name.

Pressing the Memory key for over 2 seconds at the input or output setting screen displays the Scene memory setting screen.

To revert the display back to the input or output setting screen, press the Memory key again.

(D3) Scene memory save (when SAVE is set)

SAVE<- 01 SCENE 1

Designate the memory bank number to save the current settings to.

Setting Range	01 – 32 (default: 01)
---------------	-----------------------

Pressing the Enter key saves the current settings to the designated memory bank number.

To cancel save execution, press the Escape/Back key.

Parameters that can be saved into the Scene memory bank are as follows:

- Input channel parameter: Channel gain, Channel ON/OFF, Output channel assignment, and expansion modules' inner parameters*
- Output channel parameter: Channel gain, Channel ON/OFF, Bass, Treble, Loudness compensation, EQ, HPF, LPF, Compressor, Delay, and expansion modules' inner parameters*
- Paging zone: Paging zones set in the paging setting flow

* Setting items dedicated to the D-001T, ZP-001T, T-001T or AN-001T

Note

To retain the set parameters, be sure to save them in the Scene memory. Unless otherwise saved, all the set parameters are abandoned when the AC power supply is shut off or when the other scene is loaded.

(D4) Scene memory erasure (when ERASE is set)

ERASE<- 01 SCENE 1

Erase the saved Scene memory.

Setting Range	01 – 32 (default: 01)
---------------	-----------------------

Pressing the Enter key erases the Scene memory in the designated memory bank number.
To cancel erasure execution, press the Escape/Back key.
After erasure completion, each set parameter is restored to the factory default setting.

(D5) Scene memory bank number to be recalled at power on

POWER ON<- LAST SCENE

Designate either the Scene memory bank number to be automatically recalled at power-on, or "LASTSCENE."

Setting Range	LASTSCENE (default), 01 – 32
---------------	------------------------------

When LASTSCENE is selected, the Scene memory recalled last before power-off is automatically recalled when power is turned on. When the Scene memory bank number (one of 01 – 32) is selected, the Scene memory saved there is automatically recalled when power is turned on.

Note

To retain the set parameters, be sure to save them in the Scene memory. Unless otherwise saved, all the set parameters are abandoned when the AC power supply is shut off or when the other scene is loaded.

11. HOW TO STORE OR ERASE SCENE MEMORY

A "Scene" defines the unit of broadcast pattern.

Up to 32 patterns can be stored as Scene memory in the Scene memory bank, which can then be recalled.

11.1. Recalling Scene Memory

Step 1. Press the Memory key to display the Scene memory setting screen.

01 - SCENE1



SCENESETTING LOAD

Step 2. Press the Right shift key to display the Scene memory recall screen.



LOAD < 01 SCENE1

Step 3. Select with the Parameter setting knob the Scene memory bank number to be recalled.



LOAD < 03 MORNING

Step 4. Press the Right shift key.
After recall completion, the Scene memory bank number and memory name are displayed.



03 - MORNING

11.2. Storing Scene Memory

- Step 1.** Hold down the Memory key.
The Scene memory setting screen is displayed.
- Step 2.** Rotate the Parameter setting knob to display "SAVE"
indication.
- Step 3.** Press the Right shift key to display the Scene memory
save screen.
- Step 4.** Select with the Parameter setting knob the Scene
memory bank number (01 – 32) to be stored.
- Step 5.** Press the Right shift key to store the current settings to
the designated Memory bank number.
The "SAVE COMPLETE" screen is displayed.
- Step 6.** Press the Right shift key,
The display returns to the normal use state.

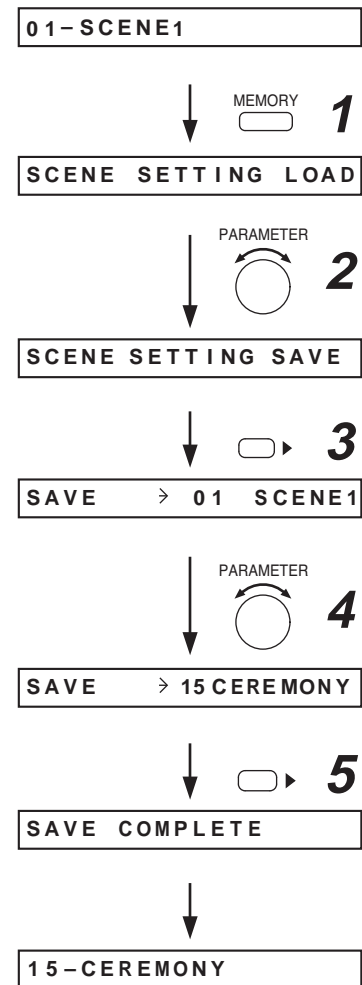

11.3. Erasing Scene Memory

- Step 1.** Hold down the Memory key.
The Scene memory setting screen is displayed.
- Step 2.** Rotate the Parameter setting knob to display "ERASE" indication.
- Step 3.** Press the Right shift key to display the Scene memory erasure screen.
- Step 4.** Select with the Parameter setting knob the Scene memory bank number (01 – 32) to be erased.
- Step 5.** Press the Right shift key to erase the setting data stored in the designated memory bank number.
After erasure completion, the display returns to the normal use state.

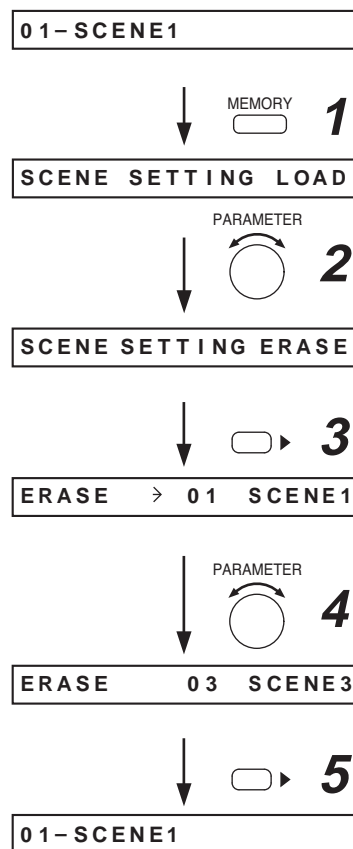

11.4. Setting the Scene Memory to be Recalled at Power-On

Step 1. Hold down the Memory key.
The Scene memory setting screen is displayed.

Step 2. Rotate the Parameter setting knob to display "P-ON" indication.

Step 3. Press the Right shift key to display the setting screen for the Scene memory to be recalled at Power-On.

Step 4. Select with the Parameter setting knob the Scene memory bank number (01 – 32) or LASTSCENE to be read at power-on.

Notes

- When LASTSCENE is selected, the Scene memory recalled last before power-off is automatically recalled when power is turned on.
- To retain the set parameters, be sure to save them in the Scene memory. Unless otherwise saved, all the set parameters are abandoned when the AC power supply is shut off or when the other scene is loaded.

Step 5. Press the Right shift key to perform setting that the designated Scene memory bank number is read at power-on.
The display returns to the normal use state.

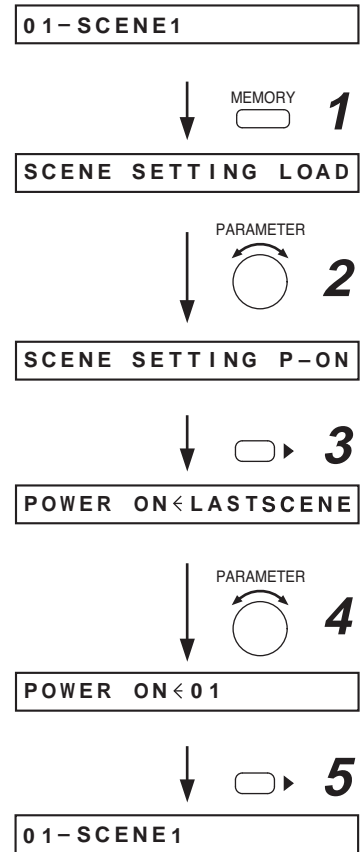

12. RESTORING FACTORY DEFAULT SETTING

Follow the procedures below to return all settings to default values while using the unit in the matrix mode. Details of the default values are shown on [the next page, "Default Setting Table."](#)

Step 1. Press the Utility key to display the utility setting screen.

01 - SCENE1

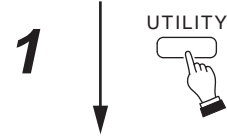

STEREO LINK

Step 2. Press the Up or Down shift key until the "MEMORY INITIALIZE" indication is displayed.

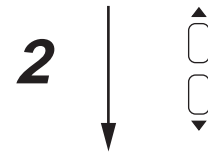

MEMORY INITIALIZE

Step 3. Press the Right shift key to display the memory initialization screen "INITIALIZE OK?" indication.



INITIALIZE OK?

Step 4. When "INITIALIZE OK?" is displayed, press the Enter key.

To cancel initialization, press the Left shift key twice to return to the screen at Step 2.

After initialization completion, the display returns to the normal use state.

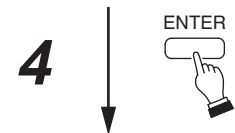

INITIALIZE,PROGRESS

Normal use state
01 - SCENE1

12.1. Default Setting Table

12.1.1. Items regarding system settings

(1) Utility settings

Setting Item	Default
Stereo Link	No channel is stereo-linked.
NOM Attenuation	0
Control Input Terminal Number	01
Control Input Terminal Function Display	NONE
Control Input Terminal Status Display	_____ (All terminals are open.)
Control Output Terminal Number	01
Control Output Terminal Function Display	NONE
Control Output Terminal Status Display	_____ (All terminals are open.)
Remote Controller Type	OFF
Remote-Controlled Channel	REMOTE1 terminal for OUTPUT1 control, REMOTE2 terminal for OUTPUT2 control (when the remote controller type is set to VOLUME or ZM-9002)
ANC Monitor Switching ON/OFF	OFF
ANC Monitor Switching Control Input Terminal	C-IN01 (When ANC monitor switching is ON)
ANC Monitor Switching Interlock Output Control	OFF (When ANC monitor switching is ON)
ANC Monitor Switching Interlock Output Terminal	C-OUT01 (When the interlock output control is ON)
Lock Status	UNLOCKED
Password	_____ (No password)
GATE Release Time	5
RS-232C Communication Speed	57.6 k
Slot Number	1
Module Classification	OTHERS

• Trigger: C-IN

Control Input Terminal	C-IN01
Interlock Output Control	OFF
Interlock Output Terminal	C-OUT01 (When Interlock output control is ON)

• Trigger: VOX

Paging Prohibition	OFF
Paging Prohibited Channel	OUT1 (When Paging prohibition is ON)
Paging Prohibited Control Input Terminal	C-IN01 (When Paging prohibition is ON)

• Trigger: ZP

Paging Prohibition	OFF
Paging Prohibited Channel	OUT1 (When Paging prohibition is ON)
Paging Prohibited Control Input Terminal	C-IN01 (When Paging prohibition is ON)

[Control input function setting]

Control Input Function	NONE
------------------------	------

• Control input function: LOADSCENE

Scene Memory Bank Number	01
--------------------------	----

• Control input function: VOLUP

Input/Output Channel Number	IN1
Volume Increasing Level	0.5 dB

• Control input function: VOLDOWN

Input/Output Channel Number	IN1
Volume Decreasing Level	0.5 dB

• Control input function: CH ON

Input/Output Channel Number	IN1
-----------------------------	-----

• Control input function: CH MUTE

Input/Output Channel Number	IN1
Interlock Output Control	OFF
Interlock Output Terminal	C-OUT01 (When Interlock output control is ON)

• Control input function: EMG-MUTE

Input/Output Channel Number	OFF
Interlock Output Control	C-OUT01 (When Interlock output control is ON)

• Control input function: PG DISABLE

Paging Prohibition	OFF
Paging Prohibited Channel	OUT1 (When Paging prohibition is ON)
Paging Prohibited Control Input Terminal	C-IN01 (When Paging prohibition is ON)

[Control output function setting]

Control Output Function	NONE
-------------------------	------

• Control output function: LD SCENE

Scene Memory Bank Number	01
--------------------------	----

• Control output function: CH ON

Input/Output Channel Number	IN1
-----------------------------	-----

(2) Memory settings

Setting Item	Default
Scene Memory Recall	01
Scene Memory Setting	SAVE

[Scene memory: SAVE]

Memory Bank Number	01
Scene Memory Name	SCENE1

[Scene memory: ERASE]

Memory Bank Number	01
--------------------	----

[Scene memory: P-ON]

Scene Memory Bank Number To Be Recalled at Power-On	LASTSCENE
---	-----------

12.1.2. Items regarding Scene settings

(1) Input settings

Setting Item	Default
Input channel Selection	IN1
Channel Control	ON
Channel Gain	0.0 dB
Channel Name	(IN1 – 8)

[Settings when the D-001T/R is used]

Phantom Power ON/OFF	OFF
Input Sensitivity	-10 dB
NOM Attenuation ON/OFF	OFF
BASS/TREBLE	0 dB
Loudness Compensation	OFF
EQ	OFF
EQ Band Number	01 (When EQ = ON and EQ band number = 01)
Gain	0 dB (When EQ = ON and EQ band number = 01)
Q	1.5 (When EQ = ON and EQ band number = 01)
Center Frequency	31.5 Hz (When EQ = ON and EQ band number = 01)
HPF	OFF
LPF	OFF
Compressor	OFF
Gate ON/OFF	OFF
Gate Threshold Level	-30 dB (When the gate function is ON)

[Settings when the ZP-001T is used]

Pre-paging Tone	OFF
Operation Mode	PAGING PORT

[Settings when the AN-001T is used]

ANC Operation ON/OFF	BYPASS
Input Sensitivity	-10 dB
Phantom Power	OFF
ANC-Activated Output	OUT1
ANC monitoring function	OFF
ANC monitor output destination	OUT1 (When the monitor ON/OFF setting is ON)
Lowest Output Level	-6 dB
Highest Output Level	0 dB
Sampling Time	20 sec
Gain Ratio	3:3
Reference Level	0 dB

[Settings when the AN-001T is not used]

Assigned Output Level	0 dB (for all the assigned output channels)
-----------------------	---

(2) Output settings

Output Channel Selection	OUT1
Channel Control	ON
Channel Gain	-20.0 dB
Channel Name	(OUT 1 – 8)
BASS/TREBLE	0 dB
Loudness Compensation	OFF
Speaker Parameter Presetting	ALL FLAT
EQ	OFF
EQ Band Number	01 (When EQ = ON and EQ band number = 01)
Gain	0 dB (When EQ = ON and EQ band number = 01)
Q	1.5 (When EQ = ON and EQ band number = 01)
Center Frequency	31.5 Hz (When EQ = ON and EQ band number = 01)
HPF	OFF
LPF	OFF
Compressor	OFF
Delay ON/OFF	OFF
Delay Time	0 (When DELAY = ON)
Paging output volume	-20 dB

12.1.3. Items regarding paging settings

(1) Input settings

Setting Item	Default
Paging ON/OFF	OFF

[Paging: ON]

Paging Input Channel	IN1
Trigger	D-001T: VOX ZP-001T: ZP
VOX threshold	-30 dB (When trigger is set to ON)
Paging Zone	1
Output Channel	OUT1

[Settings when the ZP-001T is used]

Paging Duration Time	30 sec
Paging Method	MANUAL

[Settings when the AN-001T is not used]

Setting Item	Default
Paging Priority	ZP-001T: PRIORITY 2 Modules except the ZP-001T: PRIORITY 1 (When paging function is ON)
Ducker Attenuation Level	OFF (When the ducker function is ON)

13. MODULE INSTALLATION

Important Be sure to detach the power cord when inserting or removing any module.

13.1. Module Combination

The unit is designed to provide an up to 8-input/8-output configuration in combination with its optional modules.

Inputs are configured by only using the modules. (No input terminals are located on the rear panel.)

For outputs, 2 output channels are provided on the rear panel and can be expanded by adding modules.

There are 4 control inputs and 4 control outputs on the rear panel, which can be expanded to a maximum of 12 inputs and 12 outputs with the additional use of 1 module.

900 Series input modules can also be used together with 9000 Series modules.

9000 series modules		No. of inputs	Maximum mountable No.
Model No.	Module function		
D-001T	2-channel Mic/Line input	2	4
D-001R	2-channel Mic/Line input	2	4
ZP-001T	Zone paging input	1	1
T-001T	2-channel output	—	3
C-001T	Remote control	—	1
AN-001T	2-channel ambient noise sensor input	2	2
RC-001T	Remote controller interface	—	1

900 series modules	1	8
--------------------	---	---

13.2. Channel Numbers and Terminal Numbers

- Input channel numbers 1, 2, 3... begin with the input(s) of the module inserted into Slot No. 1.
- Output channels 1 and 2 correspond to the unit's rear panel-mounted preamplifier output terminals 1 and 2, respectively. When output modules are added, the output channel numbers are 3, 4, 5....beginning with the output of the module inserted into Slot 5.
- Control input and output terminal numbers correspond to control input and output terminals 1 – 4 on the unit's rear panel. When a C-001T module is added, the additional terminal numbers are from 5 to 12.

13.3. Module Installation

The unit's rear panel-mounted module slot numbers are 1 – 8 from right to left as viewed from the rear.

There are rules for module installation. Follow the procedures below to mount the modules.

Notes

- Avoid touching parts and terminals on the module's circuit board when inserting or removing the module.
- Mount the module in the right place and certainly secure it with screws.

Step 1. Insert the D-001T or D-001R module into the slots, starting in order from Slot 1 without leaving slots open in between.

Note

Only Slots 1 – 4 can be used for the D-001T and D-001R modules. The main unit recognizes the D-001R as the D-001T.

8	7	6	5	4	3	2	Slot 1
				←			D-001T/R

Step 2. Insert the AN-001T module into the slots in order without leaving slots open in between.

Notes

- Up to 8 audio inputs including AN-001T's inputs can be used per amplifier.
- The mounting slots of the AN-001T and D-001T/R may be changed between them.

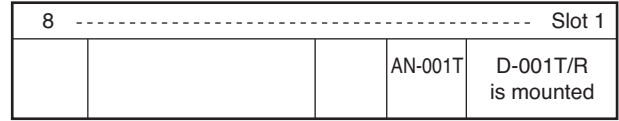

(Example when no D-001T/R is mounted)



Step 3. Insert the T-001T module into the slots, starting in order from Slot 5 without leaving slots open in between.

Note

Only Slots 5 – 7 can be used for the T-001T module.

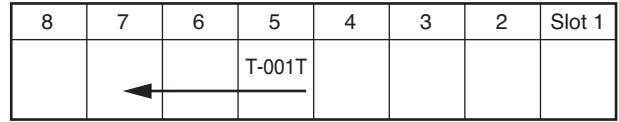

Step 4. Insert the ZP-001T module(s) into the slots in order without leaving slots open in between.

Note

Start the insertion from Slot No. 1 when neither D-001T/R nor AN-001T module is used.

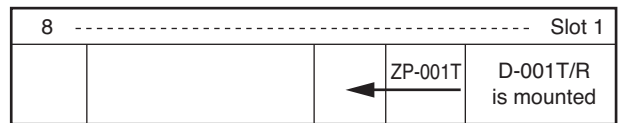

(Example when neither D-001T/R nor AN-001T is mounted)

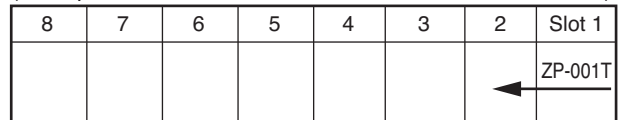

Step 5. Insert the 900 Series input modules.

Notes

- When Slot No. 1 is occupied with the D-001T/R or AN-001T, Slot No. 8 is not used for the 900 Series module. Likewise, when Slot No. 2 is occupied, Slot No. 7 is not used; when Slot No. 3 is occupied, Slot No. 6 is not used; and when Slot No. 4 is occupied, Slot No. 5 is not used.
- Insert the 900 Series input modules in order without leaving slots open in between.
- Use the open slots in increasing slot number order even if the T-001T module is mounted in an intermediate position.
- Insert modules into the slots, starting in order from Slot No. 1 when not mounting the D-001T/R, AN-001T, and ZP-001T.

(Example when the T-001T is mounted in an intermediate position)

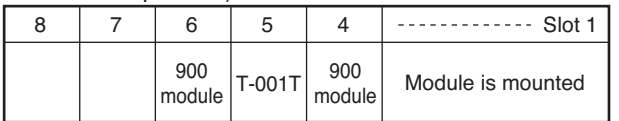

(Example when neither D-001T/R, AN-001T, nor ZP-001T is mounted)

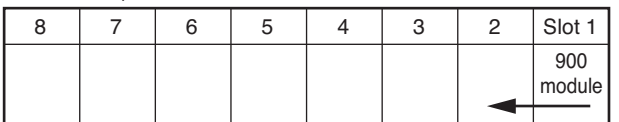

Step 6. Insert the RC-001T module in the open slot with the lowest slot number.



Step 7. Insert the C-001T module in the open slot with the lowest slot number.

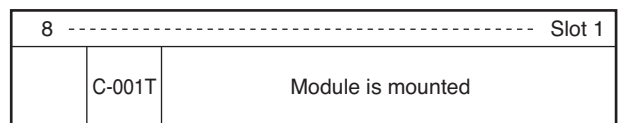

Step 8. Attach the blank panels supplied with the unit onto open slots.

Note

If modules are not correctly installed, an error indication is displayed on the VFD screen when the power is turned on. In such cases, check the above procedures again and reinsert the modules.

(Example for an error indication)



13.4. Module Installation Examples

[Example of audio 8 IN/8 OUT and control 12 IN/12 OUT configuration]

8	7	6	5	4	3	2	1	Slot No.
C-001T Control 8 inputs 8 outputs	T-001T Audio 2 outputs	T-001T Audio 2 outputs	T-001T Audio 2 outputs	D-001T/R Audio 2 inputs	D-001T/R Audio 2 inputs	D-001T/R Audio 2 inputs	D-001T/R Audio 2 inputs	

[Example of audio 5 IN/4 OUT, control 4 IN/4 OUT, and ambient noise sensor 2 IN configuration]

8	7	6	5	4	3	2	1
Open slot (Attach the blank panel)	Open slot (Attach the blank panel)	900 series module Audio 1 input	T-001T Audio 2 outputs	900 series module Audio 1 input	900 series module Audio 1 input	AN-001T Ambient noise sensor 2 inputs	D-001T/R Audio 2 inputs

[Example of audio 2 IN/4 OUT, control 4 IN/4 OUT, and ambient noise sensor 2 IN configuration
(Remote control module included)]

8	7	6	5	4	3	2	1
Open slot (Attach the blank panel)	RC-001T Control input/output	Open slot (Attach the blank panel)	T-001T Audio 2 outputs	Open slot (Attach the blank panel)	900 series module Audio 1 input	ZP-001T Audio 1 input	AN-001T Ambient noise sensor 2 inputs

14. CONNECTIONS(EXAMPLE FOR CP-9500M2-EB)

14.1. Control I/O Terminal Connections

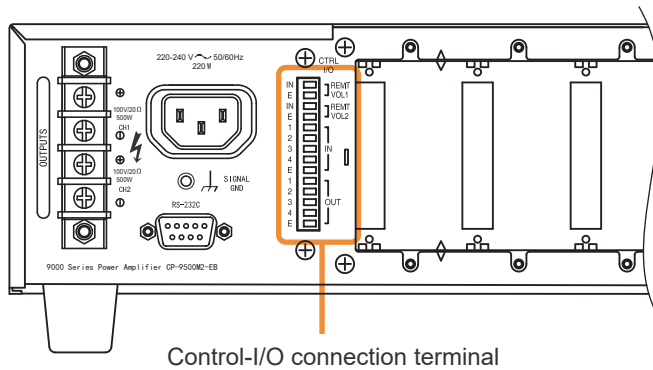

[Remote volume control terminals 1, 2 (REMT VOL 1, REMT VOL 2)]

Volume of the input or output channels can be remotely adjusted by connecting a variable resistor or variable DC power supply unit. (The REMT VOL 1 terminal is factory-preset to output 1, and the REMT VOL 2 to output 2.)

Connect a 10 k Ω (linear taper) variable resistor or input the DC voltage of 0 to +10 V as shown below.

The larger the variable resistor resistance, the larger the volume is, and the smaller its resistance, the smaller the volume is.

Connecting the ZM-9001 Zone Manager adds 6 control inputs and allows the equipped 6 control buttons to perform the functions assigned for input's or output's channel volume up/down, or Scene memory recall.

Connecting the ZM-9002 Zone Manager adds 1 volume control and 4 control inputs. Volume of the input or output channels can be remotely adjusted with the volume control, and the 4 control buttons can be assigned the same functions as those of the ZM-9001.

Note

To avoid interference due to noise, use shielded cables.

[Control input terminals 1 – 4 (IN 1 – 4)]

Connect switch contacts, etc. to these terminals.

Open voltage is 3.3 V, and the short-circuit current is 1 mA or less.

[Control output terminals 1 – 4 (OUT 1 – 4)]

Use these terminals to activate LEDs, relays, and other external equipment.

Maximum operating current is 50 mA, and the maximum applicable voltage is +27 V.

14.1.1. When a variable resistor or variable DC power supply unit is connected

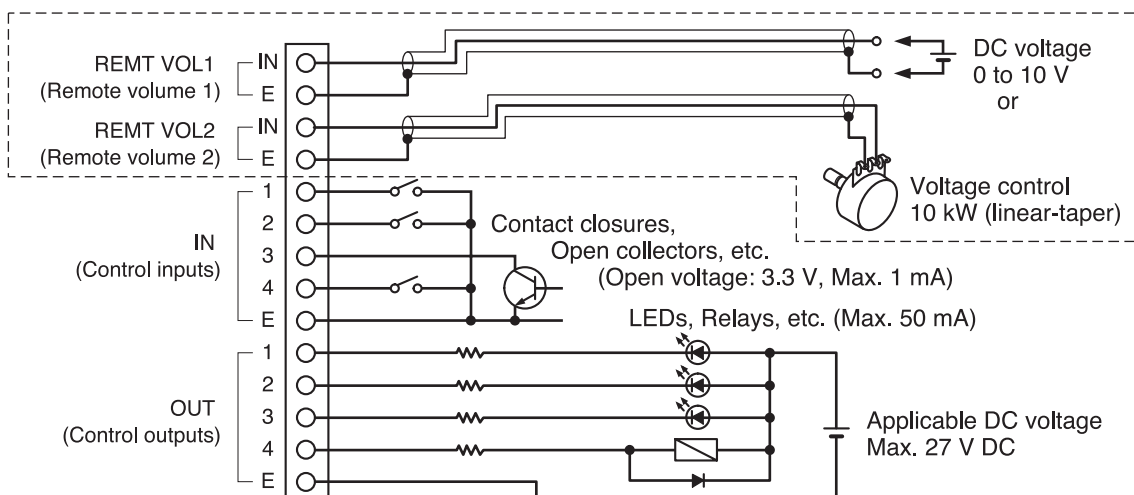

14.1.2. When the ZM-9001 or ZM-9002 is connected

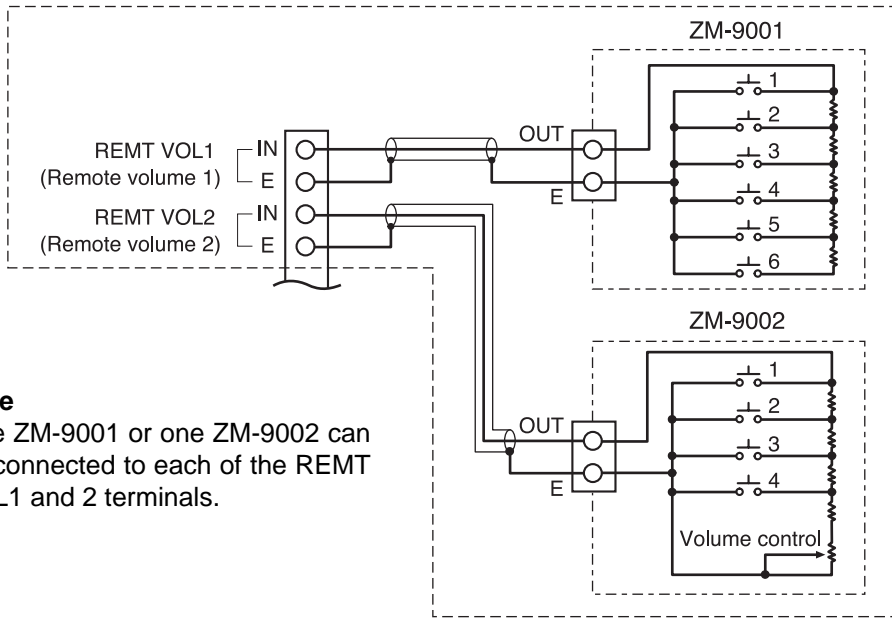

Note
One ZM-9001 or one ZM-9002 can be connected to each of the REMT VOL1 and 2 terminals.

14.1.3. When the ZM-9003 is connected

Output terminal Nos. 1 – 4 of the ZM-9003 are internally connected to the interlocking switches and Nos. 5 and 6 to the momentary switches. Connect these terminals to the Control input terminals of the main unit or C-001T depending on applications.

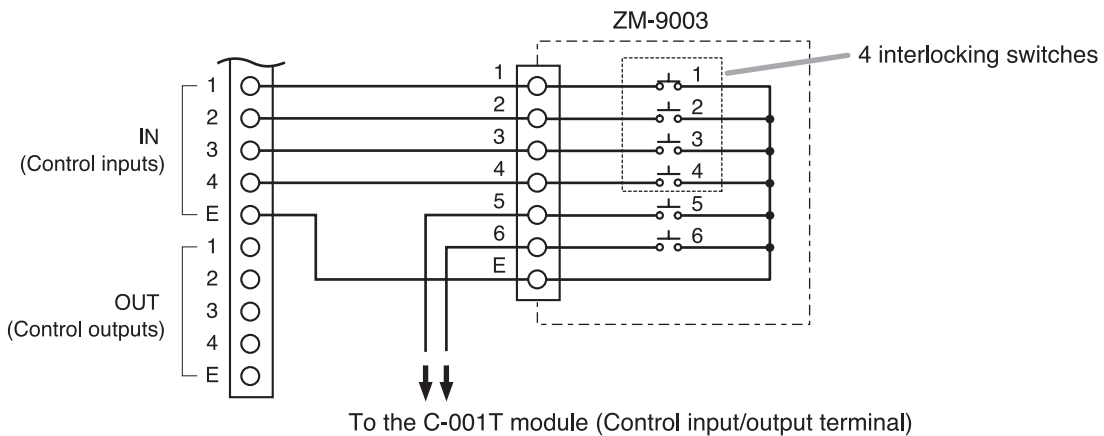

14.1.4. When the SS-9001 is connected

The control input terminals of SS-9001 are polarized non-voltage contact inputs. When the control output terminals of 9000 series are closed, the corresponding internal relays of the SS-9001 are activated. Make necessary connections depending on applications.

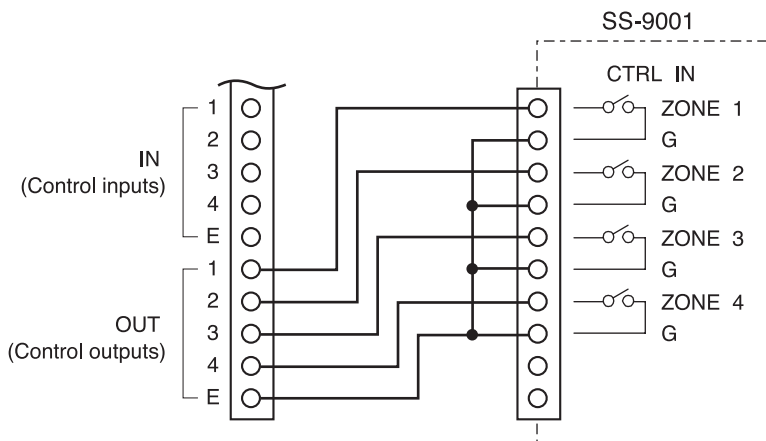

14.1.5. Operation by control input

[Pulse trigger]

Use this method to activate operations for which no definite end can be defined, such as "VOL UP/DOWN" (Volume Up/Down), "LOADSCENE" (Scene memory recall), and "CH ON." Minimum pulse width is 100 ms.

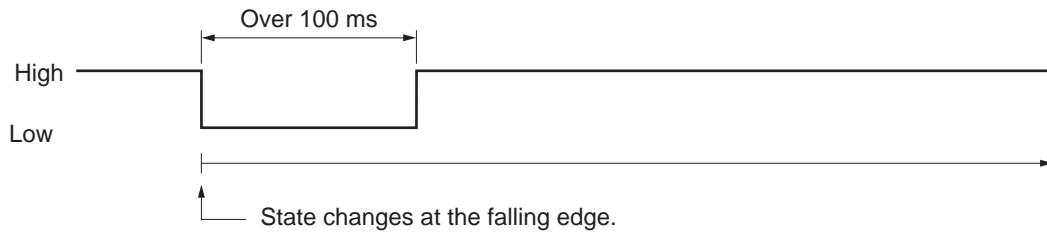

[Level trigger]

Use this method to activate "CH MUTE" (Channel mute), "POWER" (Power ON/OFF remote function), "EMG-MUTE" (Cut-off by emergency control), paging broadcasts, and other operations of which start and end must be defined.

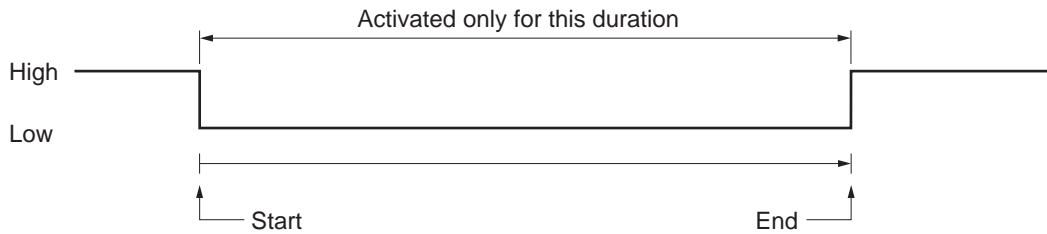

For "CH MUTE," "POWER," and "EMG-MUTE" functions, if operated at the front panel (EMG-MUTE does not accept this access from the front panel) or if other control input to which the same function is assigned is fed, their states are changed by subsequent panel operations or control input activations. The following example shows the change in operation when POWER (Power ON/OFF remote function) is assigned to Control inputs 1 and 2;

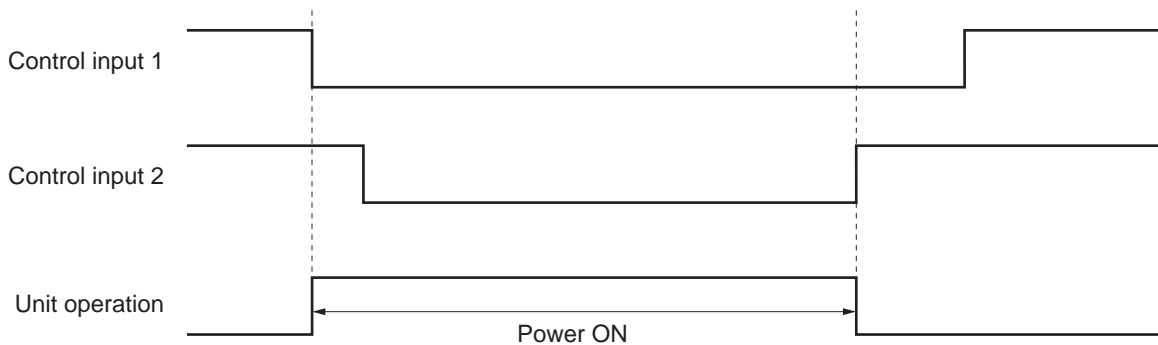

Control input 1 will still keep the power ON after Control input 2 turns the power OFF, however the unit's power is OFF.

14.2. Speaker Output Terminal Connections

Both CH 1 and CH 2 outputs are provided on the 4P speaker terminal.
Connect the speaker to the speaker output terminals.

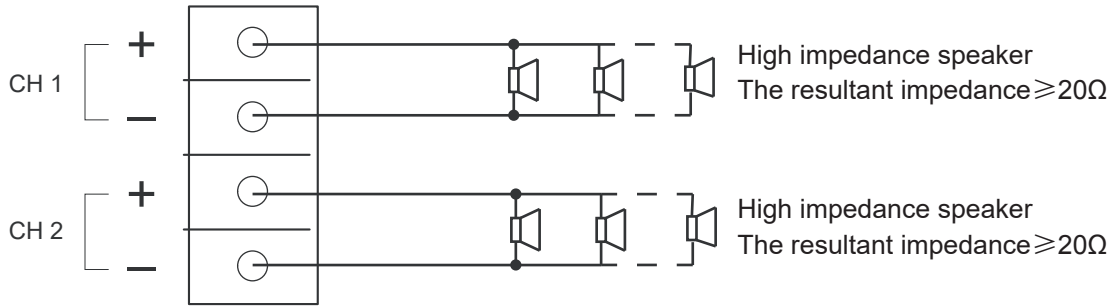

14.3. C-001T Module Connections

14.3.1. Control input terminal

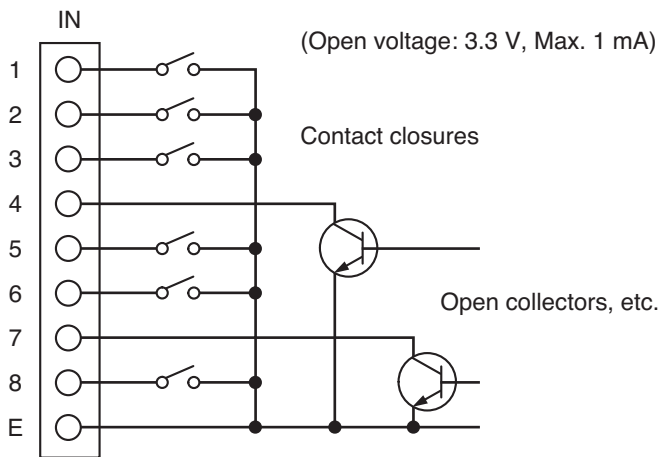

For operation by means of the control inputs, refer to p. 111 "Operation by control input."

14.3.2. Control output terminal

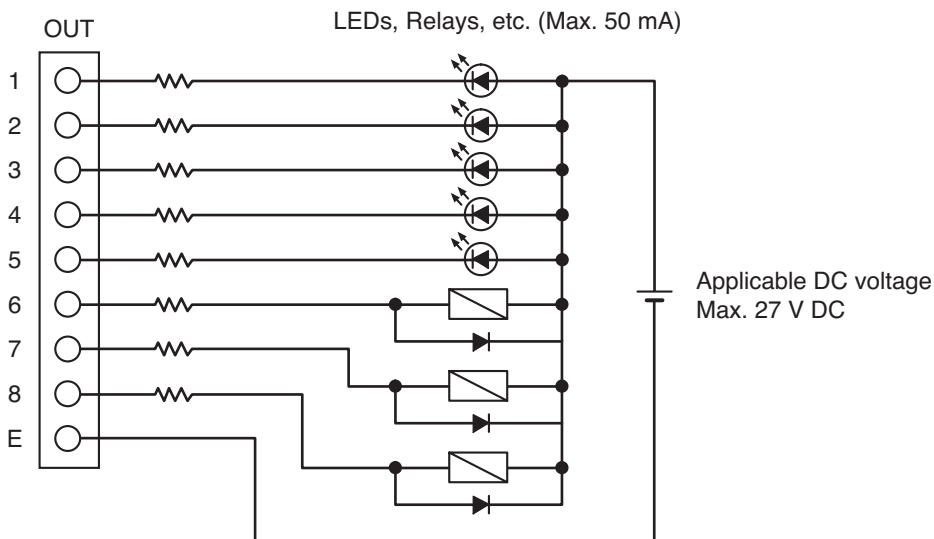

14.3.3. Connecting the ZM-9003

Output terminal Nos. 1 – 4 of the ZM-9003 are internally connected to the interlocking switches and Nos. 5 and 6 to the momentary switches.

Connect these terminals to the Control input terminals of the main unit or C-001T depending on applications.

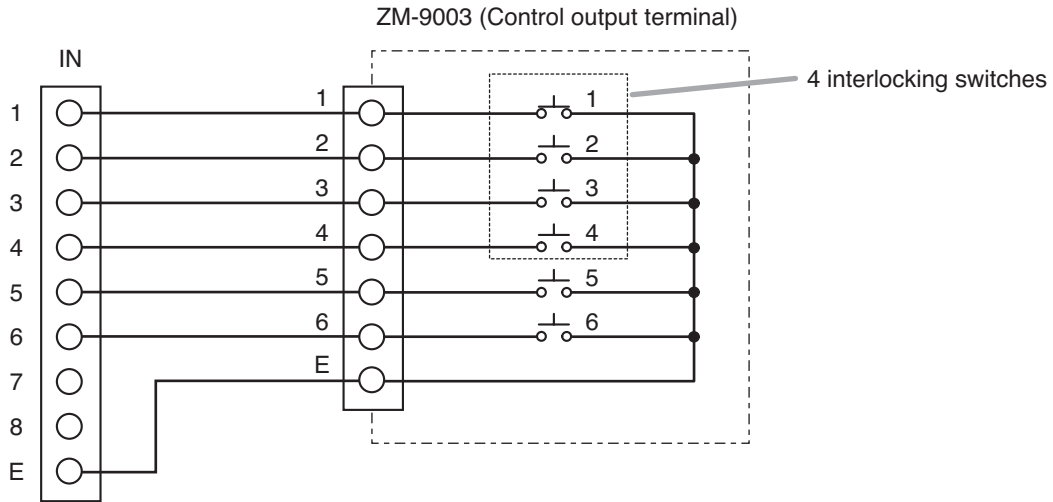

14.3.4. Connecting the SS-9001

The control input terminals of SS-9001 are polarized non-voltage contact inputs.

When the control output terminals of C-001T are closed, the corresponding internal relays of the SS-9001 are activated.

Make necessary connections depending on applications.

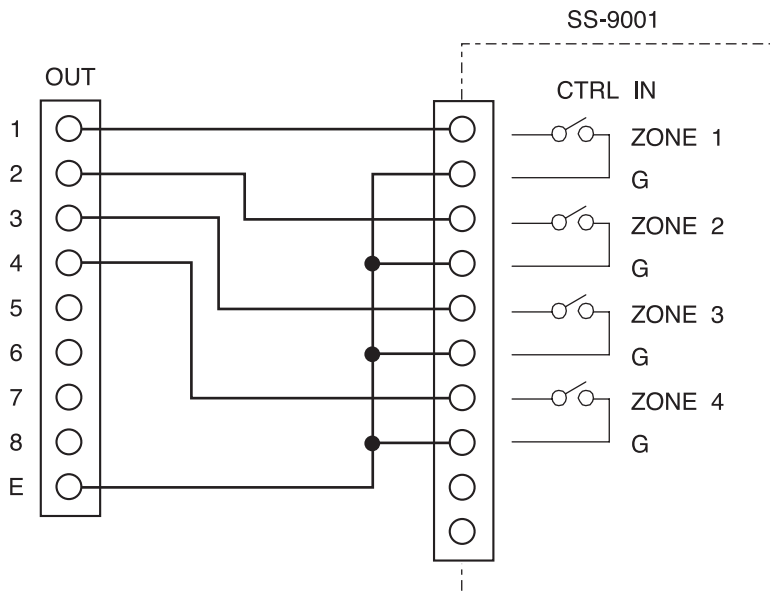

14.4. RC-001T Module Connection

14.4.1. Connection method

To connect the RC-001T Remote Control Module to the Remote control panels such as ZM-9011, ZM-9012, ZM-9013, or ZM-9014, connect the same DATA BUS terminals and the same 24 V DC terminals of the both units.

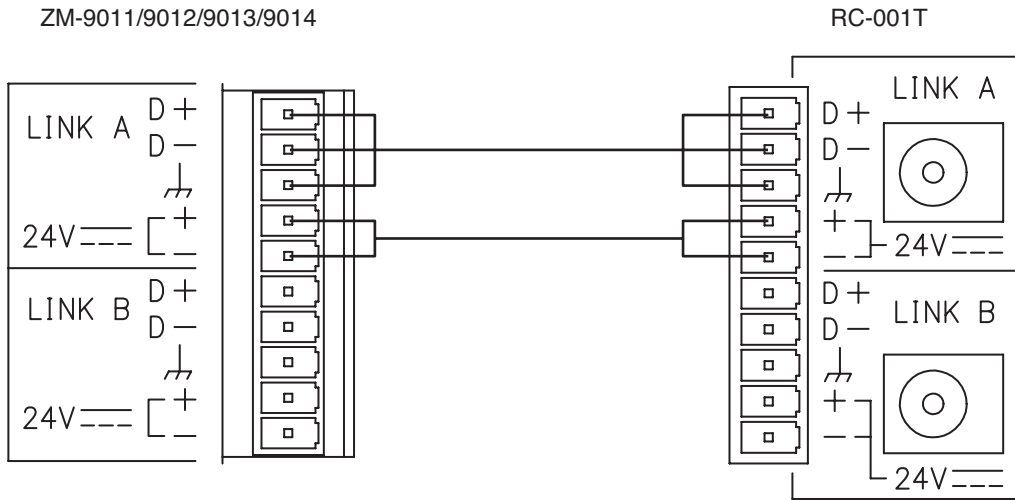

Connect the AC adapter to the RC-001T to supply the power to the Remote control panel.

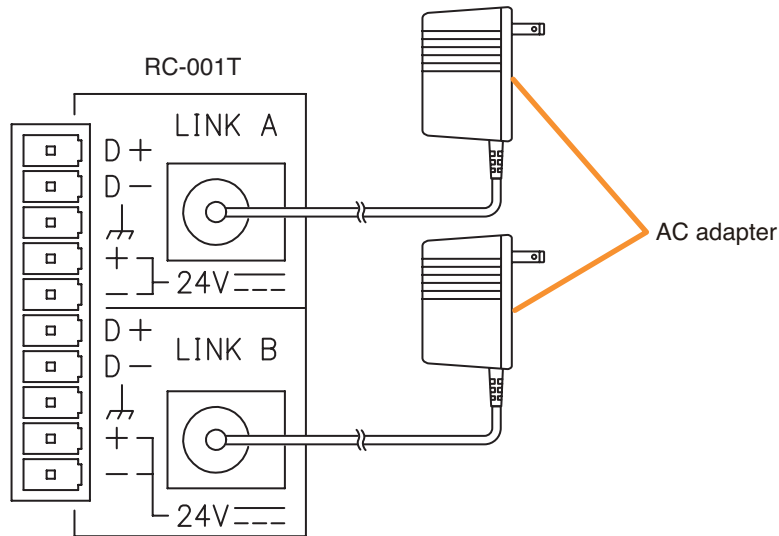

A single AC adapter is required for each BUS channel.

A single AC adapter can supply power up to 8 Remote control panels per channel.

Up to 16 Remote control panels can be connected to the RC-001T. In this case, 2 AC adapters are required to supply power to 8 units on each channel.

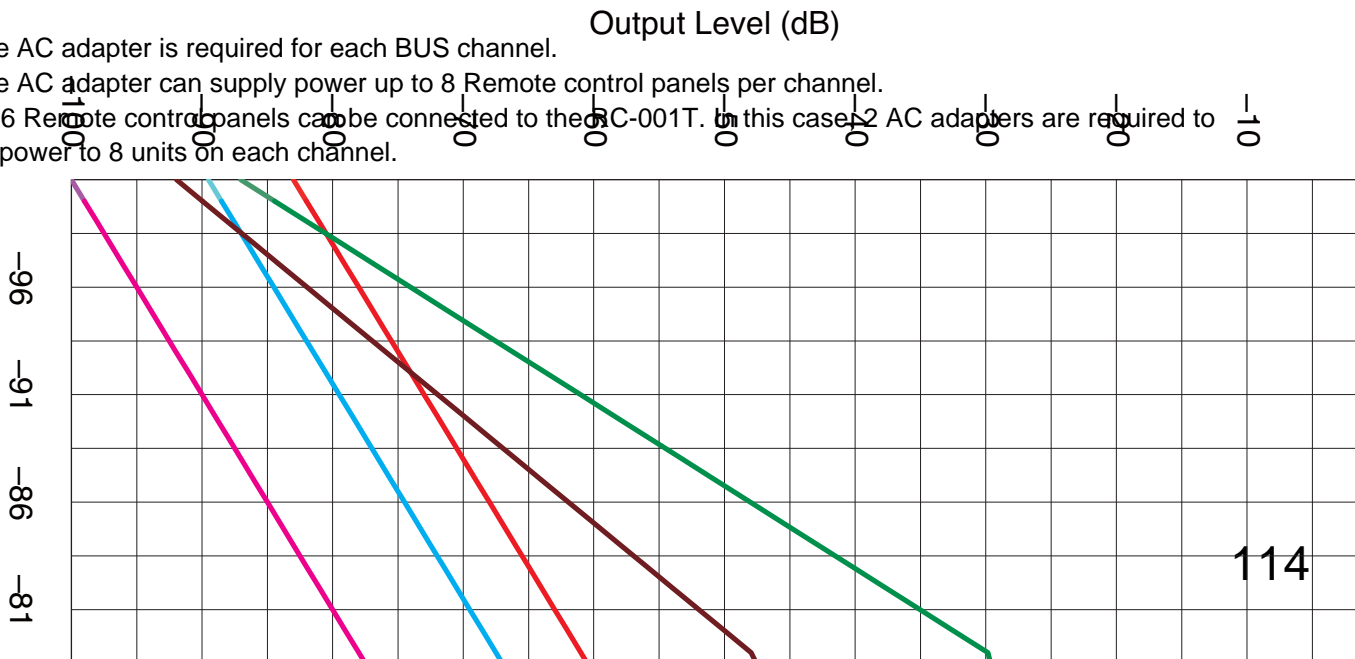

14.4.2. Cable distance

Cable distance between the RC-001T and Remote control panels (ZM-9011/9012/9013/9014), and the number of connected Remote control panels differ depending on the connection method as shown below.

[Star connection configuration]

The maximum cable distance between the RC-001T and each Remote control panel is 800 m (875 yd) in total.

Example: Up to 16 panels can be connected when the total cable distance is within 800 m (875 yd).

(When one Remote control panel is connected)

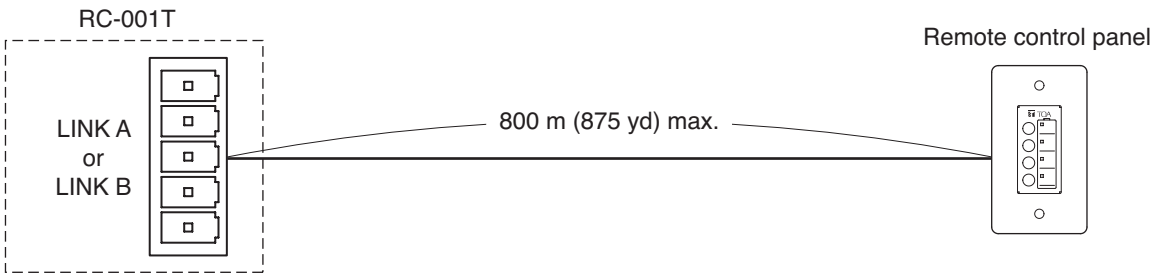

(When 16 Remote control panels are connected)

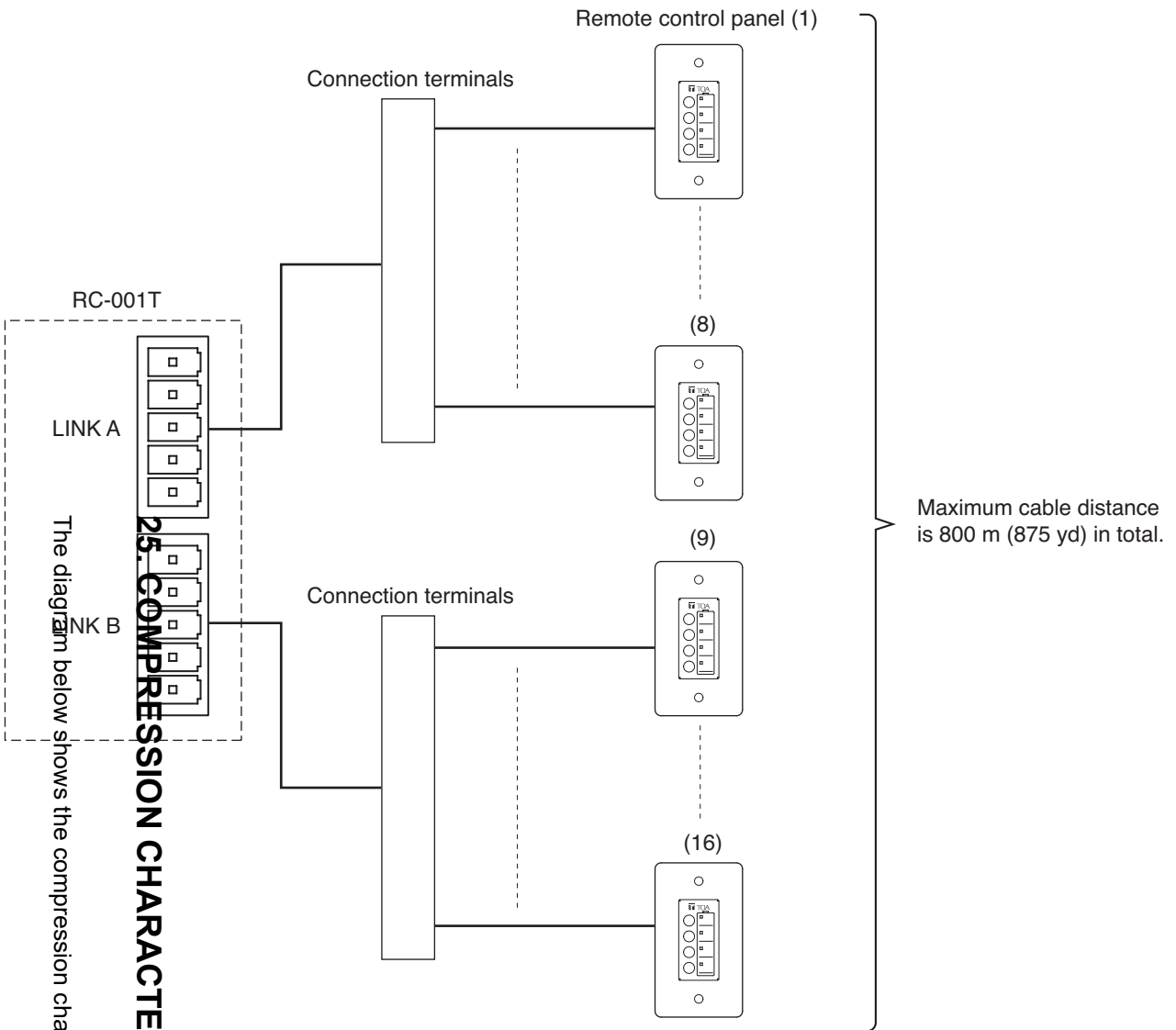

25. COMPRESSION CHARACTERISTICS
 The diagram below shows the compression characteristics on

[Daisy-chain connection configuration]

The number of connected Remote control panels differs depending on the cable distance.

When 16 panels are connected, the maximum cable distance for each LINK A and LINK B is 200 m (220 yd).

Example 1: When each cable for LINK A and LINK B is extended up to 200 m or 220 yd (400 m or 440 yd in total), 16 panels can be connected irrespective of the distance between RC-001T and panels, and between panels.

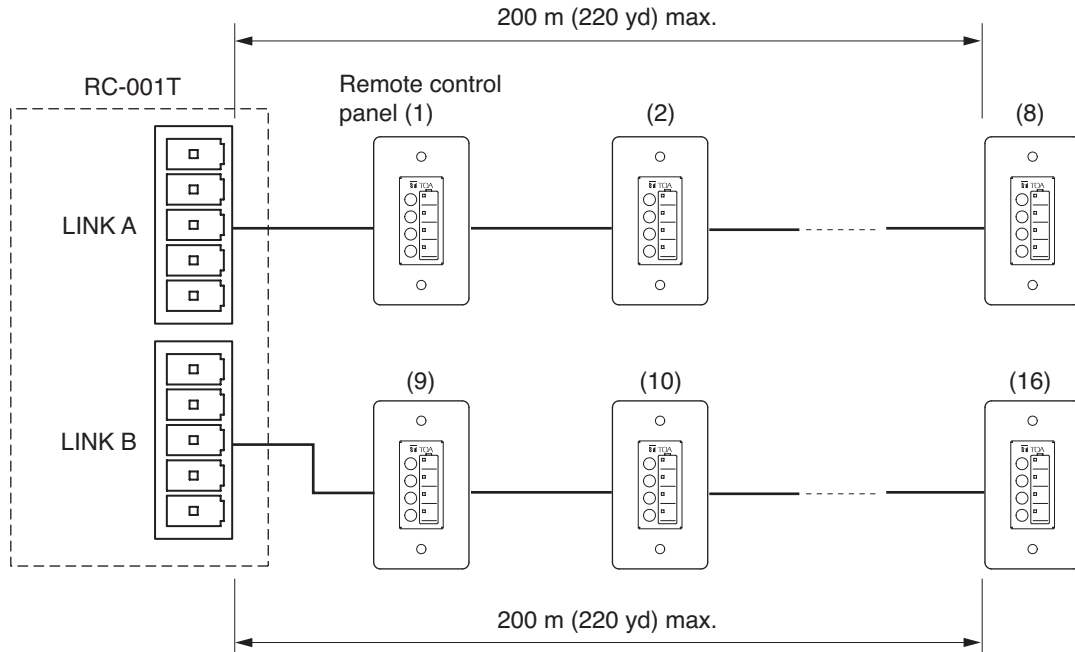

Example 2: When each cable for LINK A and LINK B is extended up to 300 m or 330 yd (600 m or 660 yd in total), 14 panels can be connected irrespective of the distance between RC-001T and panels, and between panels.

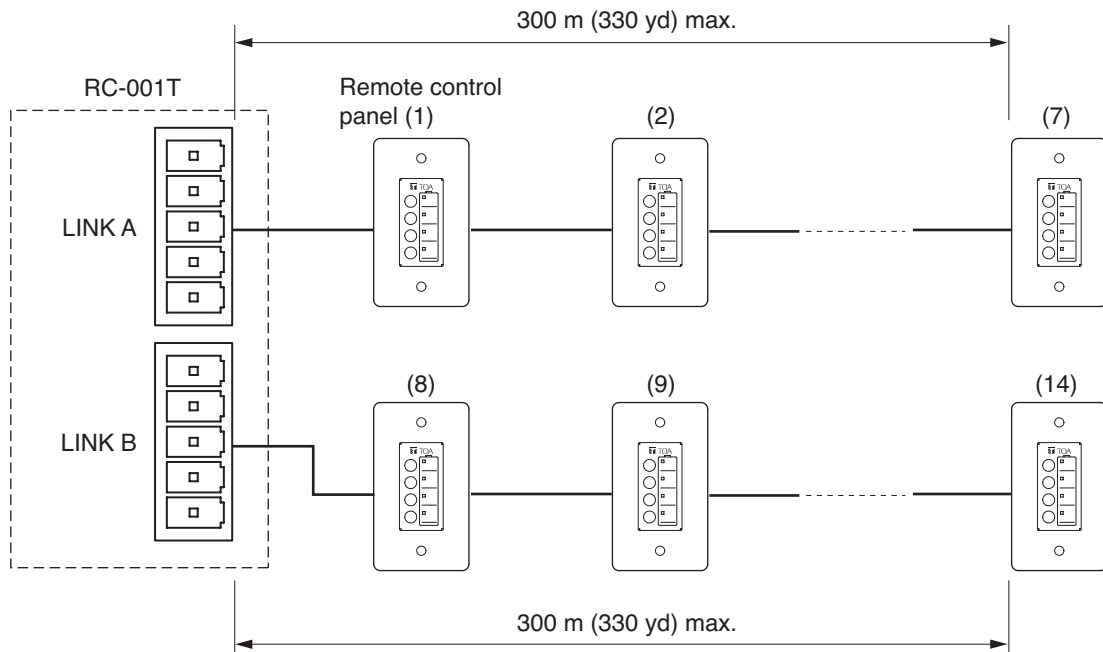

Example 3: When each cable for LINK A and LINK B is extended up to 400 m or 440 yd (800 m or 875 yd in total), 12 panels can be connected irrespective of the distance between RC-001T and panels, and between panels.

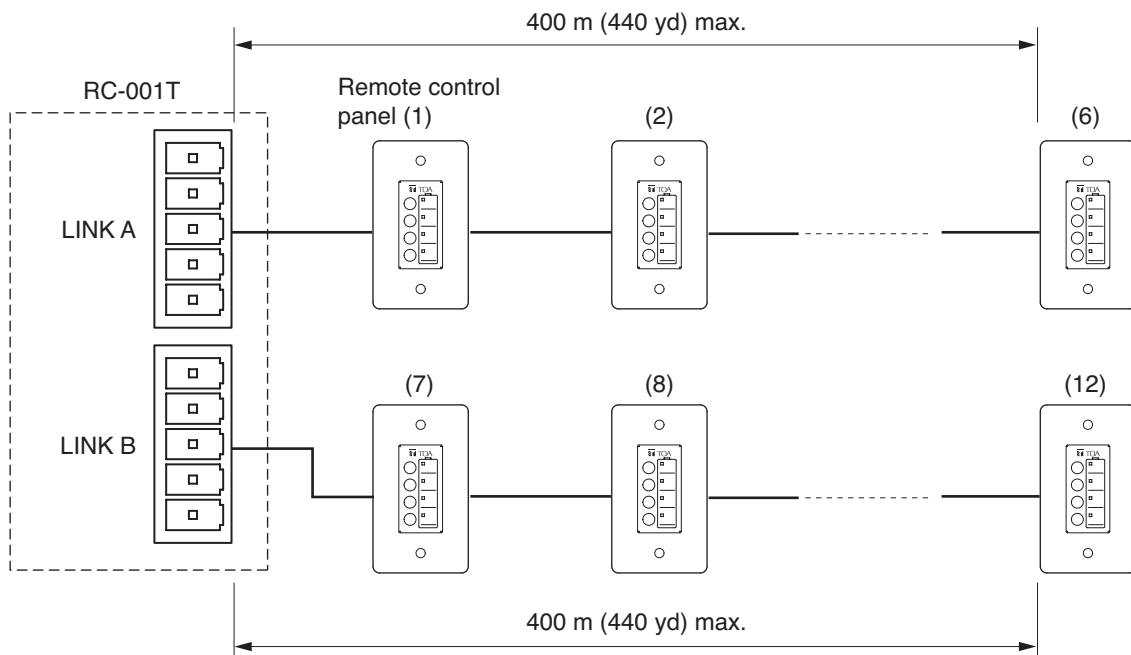

Notes

- In the daisy-chain connection, the cable distance for each LINK A and LINK B should be within 400 m (440 yd).
If extended beyond 400 m (440 yd), the Remote control panels may not operate.
- Do not mix the star connection with daisy-chain connection. Mixing both connection configurations may cause the Remote control panels to malfunction.

14.5. RS-232C Connector Connection

Use the straight cable when connecting a PC to the unit's RS-232C connector (9P, female).

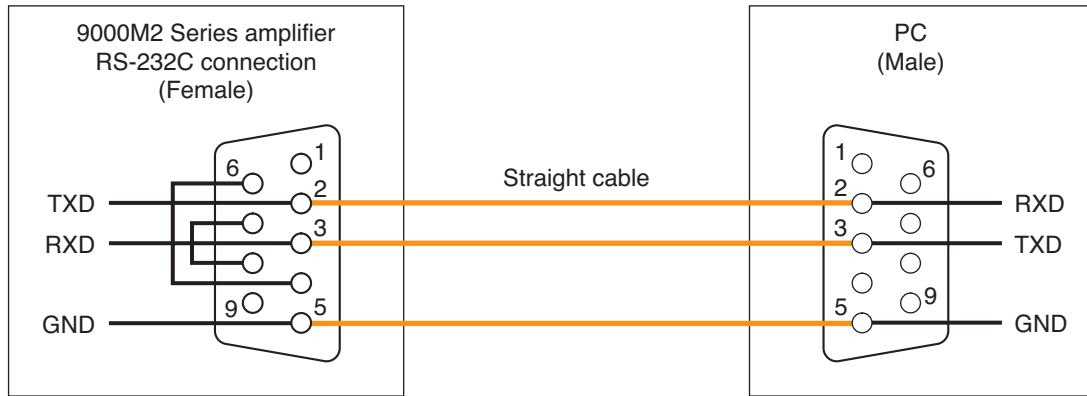

14.6. AN-001T and AN-9001 Connections

The AN-001T and AN-9001 are connected as illustrated below and used to control the speaker sound volume in a room or such closed space.

Note

Keep the AN-9001 as distant as possible from a sound source (speaker, water supply pipe, or air conditioning).
 If installed close to a sound source, the AN-9001 could sense it as ambient noise to control the speaker sound volume.

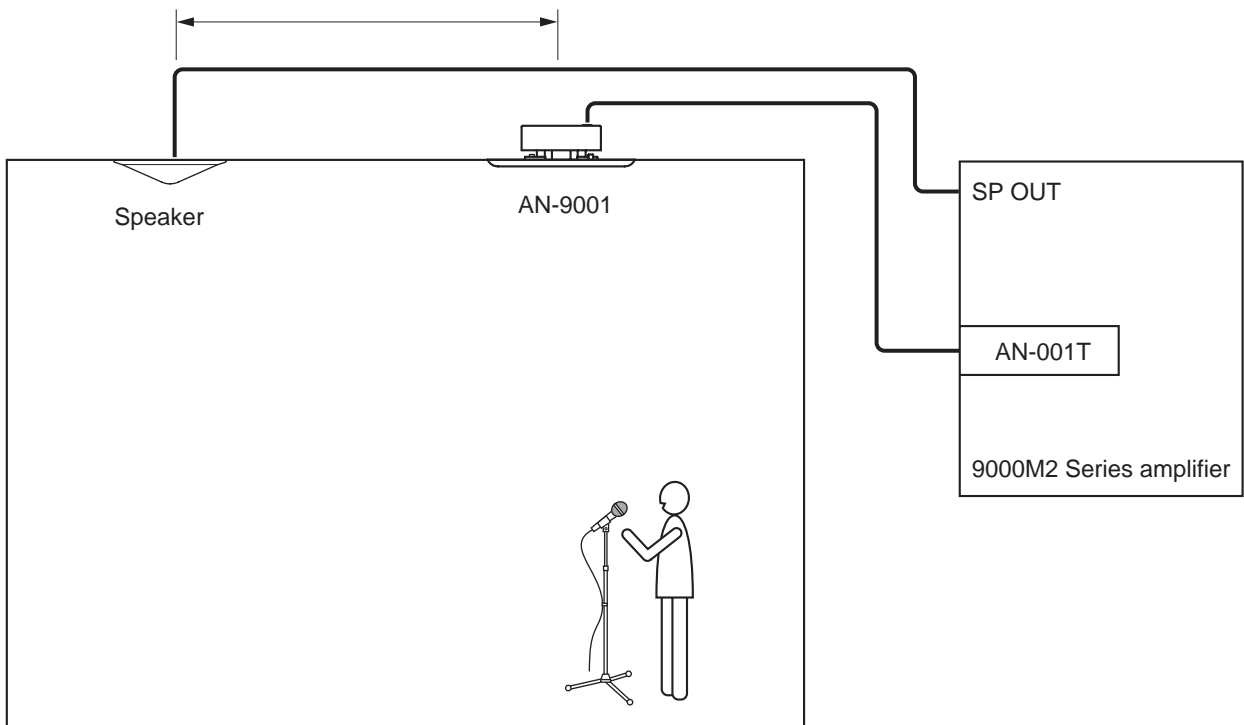

14.7. Power Source Connections to the SS-9001

14.7.1. When using a 24 V DC power source

Connect a 24V DC power source to the SS-9001's DC input terminal pins.

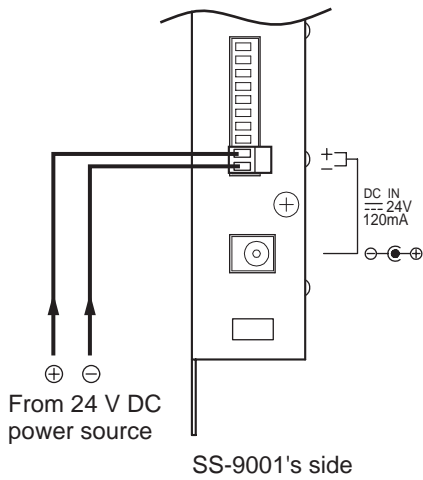

Notes

- The DC power supply unit should be capable of supplying 200 mA or more.
- The DC power fed to this terminal should be from 21.6 to 26.4 V. If the input voltage exceeds this range, the SS-9001 may malfunction or fail.

14.7.2. When using the optional AC adapter

Connect the optional AD-246 AC Adapter to the SS-9001's DC input terminal. Pinch the adapter cord with the cord clamp to securely fix the cord.

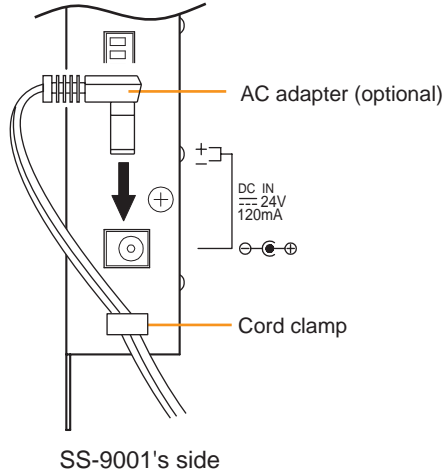

14.8. Removable Terminal Plug Connection

Be sure to use the supplied removable terminal plugs for connections to the removable terminal blocks.

Cautions

- Be sure to use shielded cables for audio signal lines and for the ZM-9001/9002/9011/9012/9013/9014 control lines.
- Avoid soldering stranded or shielded cable, as contact resistance may increase when the cable is tightened and the solder is crushed, possibly resulting in an excessive rise in joint temperatures.

Cable end treatment

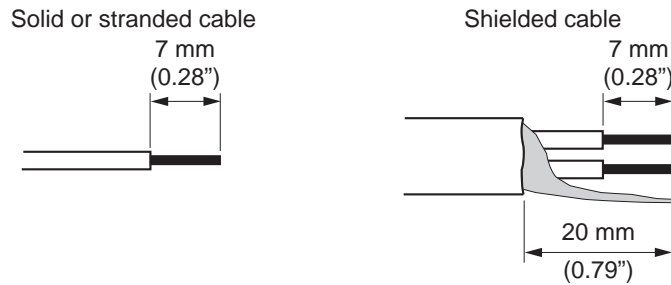

Connector connection

Step 1. Loosen the terminal screw, then insert the cable.

Step 2. Retighten the terminal screw. (Pull on the cable to ensure it is securely connected.)

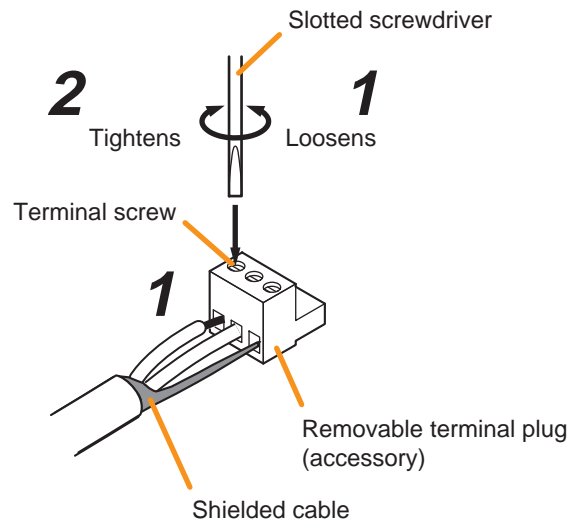

Tip

Recommended slotted screwdriver type: Screwdriver with 3 mm (0.12") blade width

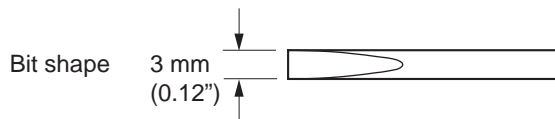

15. RACK MOUNTING BRACKET ATTACHMENT

Use the supplied rack mounting bracket when mounting the unit in an equipment rack.

Step 1. Remove four M4 x 8 screws on the sides.
The removed screws are no longer used.

Step 2. Attach the rack mounting bracket to the unit using the supplied four M4 x 16 bracket mounting screws.

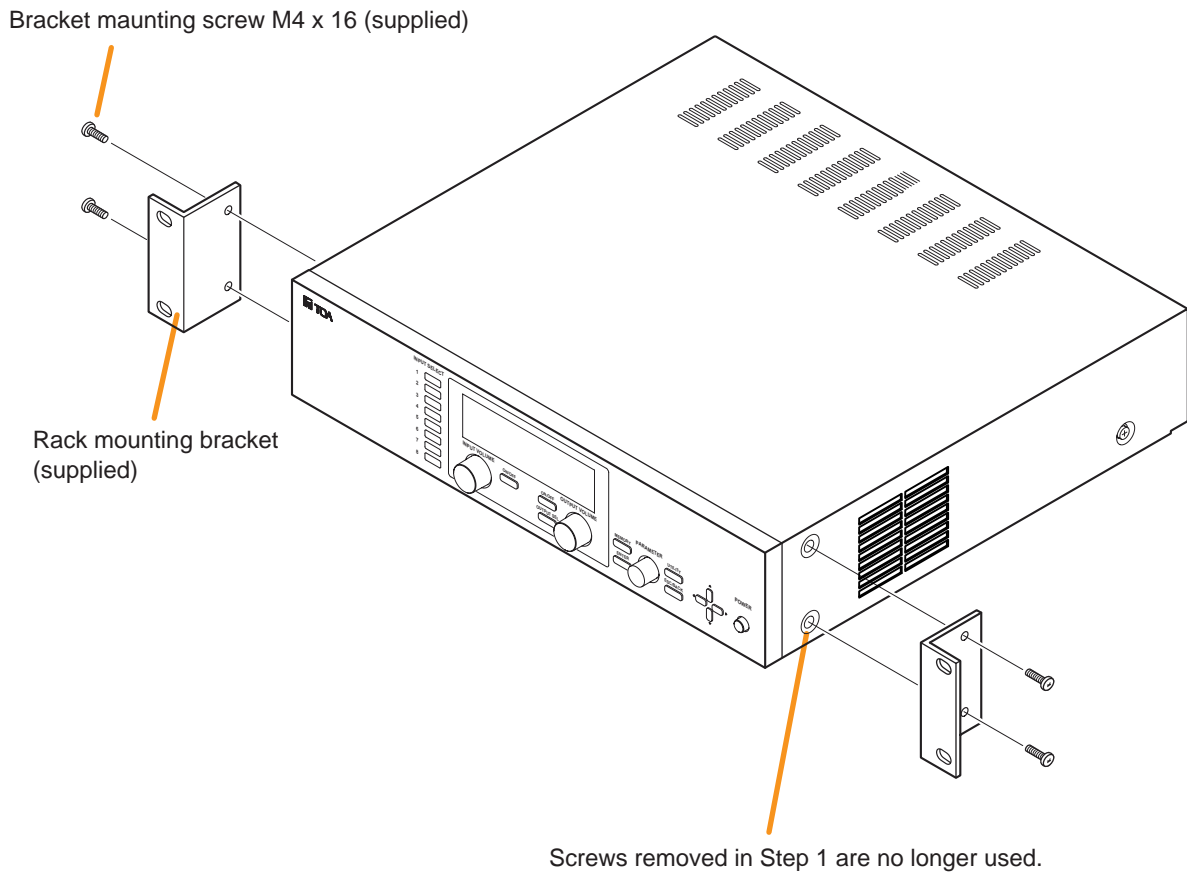

Notes

- Remove 4 plastic feet on the bottom surface when mounting the unit in a rack.
- Rack mounting screws are not supplied with the unit. Use the screws that are appropriate for the rack.
- Install the unit at a well-ventilated place, and be sure to mount a 1U or more size perforated panel above and below the unit to prevent the unit's internal temperature rise.

16. CLEANING THE FILTER

Step 1. Turn off this unit's Power switch.

Step 2. Remove two M3 x 8 screws on the ventilation panel.

Step 3. Remove the ventilation panel as shown in the figure.

Step 4. Detach the filter inside the ventilation panel.

Step 5. Clear the filter of dust.

Step 6. Replace the filter and ventilation panel.

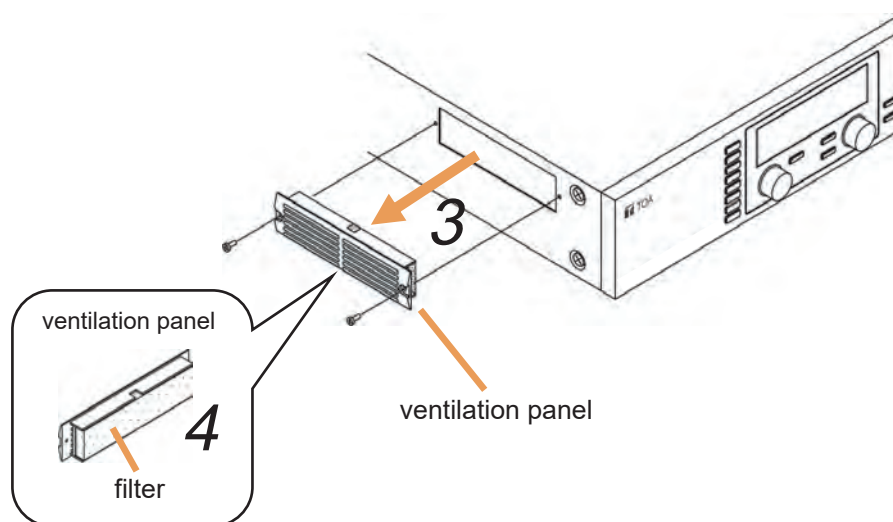

17. AN-9001 INSTALLATION

Step 1. Install a 1-gang electrical box in a wall or ceiling.

Step 2. Mount the AN-9001's Main unit to the installed electrical box.
Use the 2 screws (No.6-32UNC x 30) supplied with the AN-9001.

Note

The AN-9001 comes with 2 types of machine screws: No.6-32UNC x 30 (unified threads) and M4 x 30 (metric threads). Be sure to use correct ones.

Step 3. Let both detents on the panel's rear into the detent insertion openings of the Main unit.

Tips

For detent insertion, refer to the following points:

(A) Align 2 triangular marks on the panel with the extended line connecting between Main unit's mounting screws.

(B) Align the panel's center hole with the Main unit's microphone.

Step 4. Rotate the panel clockwise.

The panel locks into place by rotating it about 20° in the "Lock" direction.

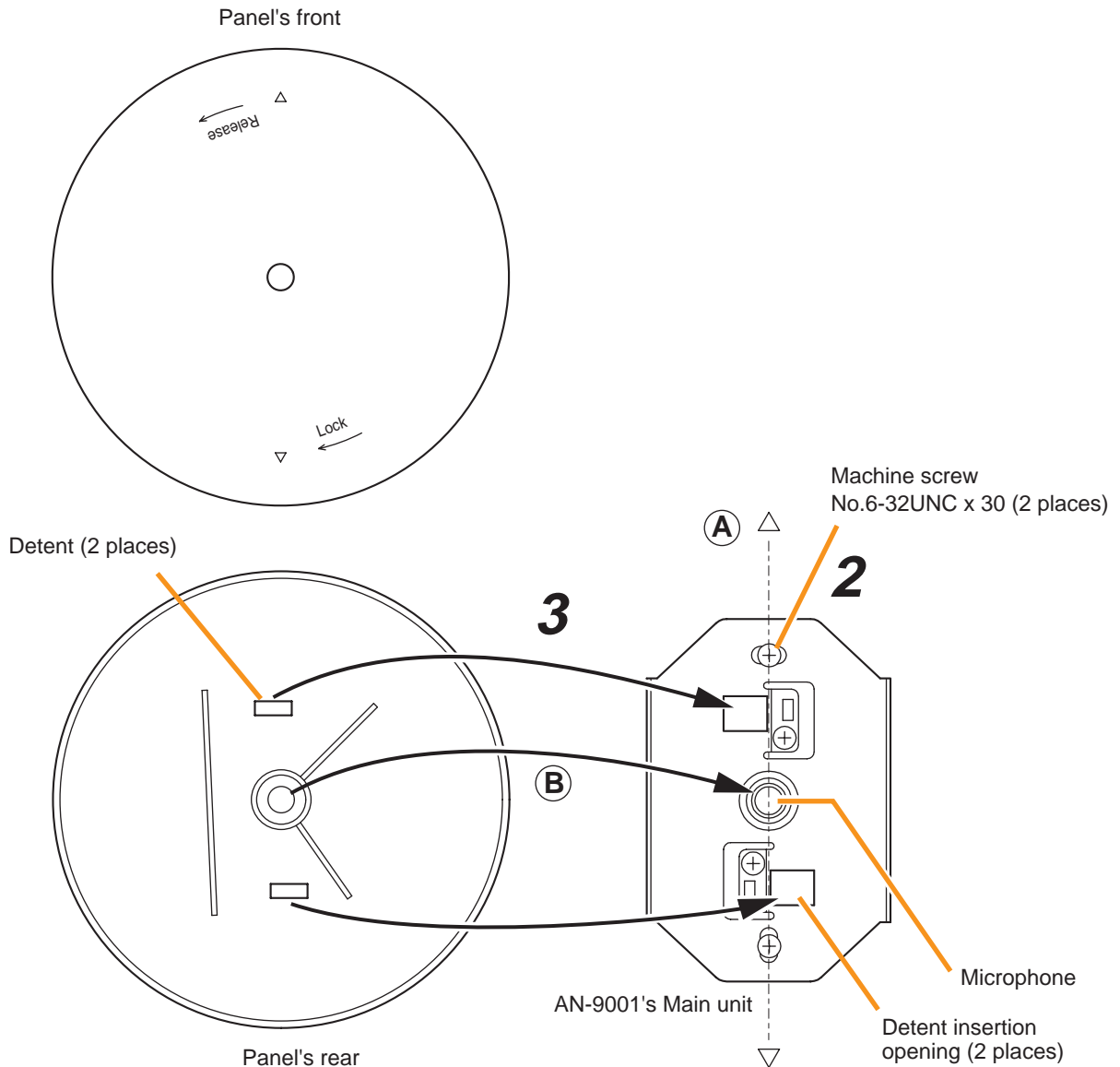

18. DIMENSIONAL DIAGRAMS

18.1. AN-9001

Unit: mm (in)

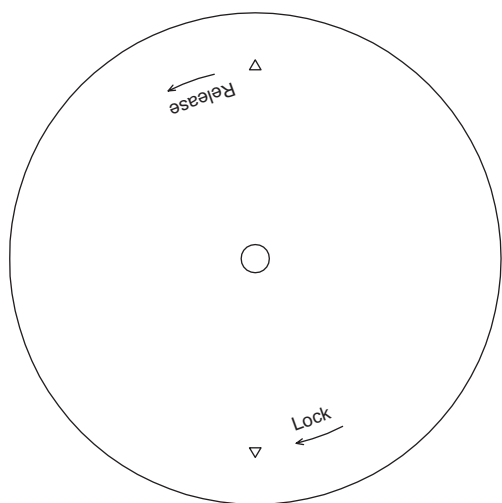

[Front]

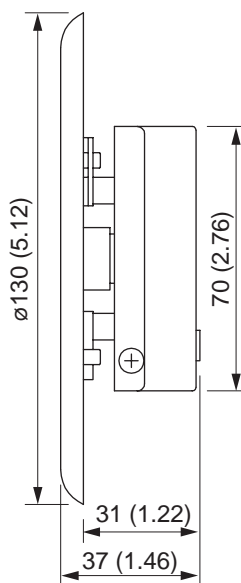

[Side]

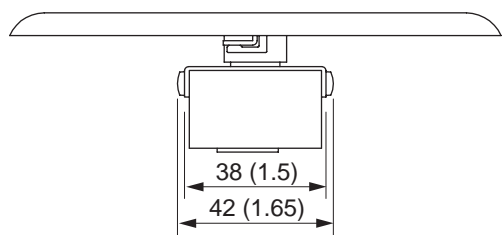

[Bottom]

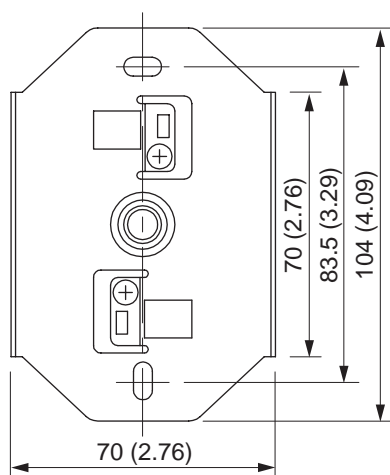

[Front view of Main unit]

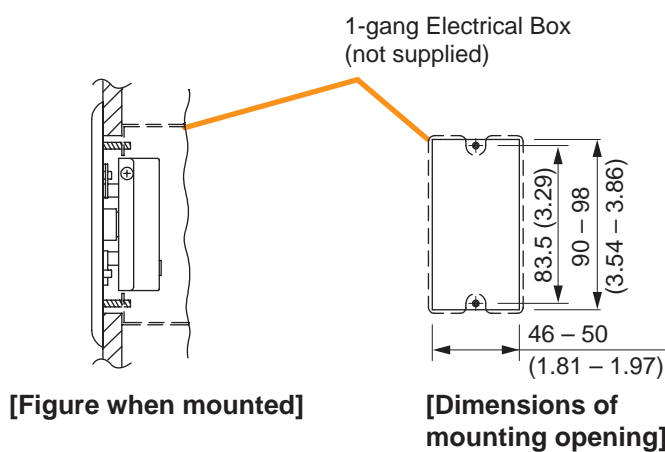

[Figure when mounted]

[Dimensions of mounting opening]

18.2. ZM-9001

Unit: mm (in)

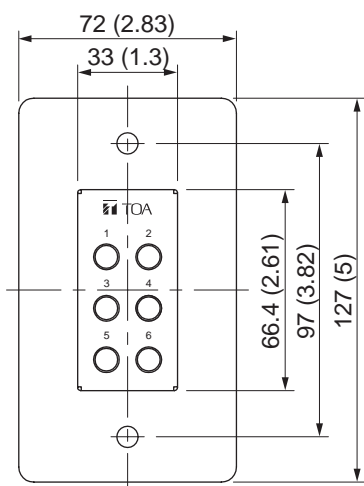

[Front]

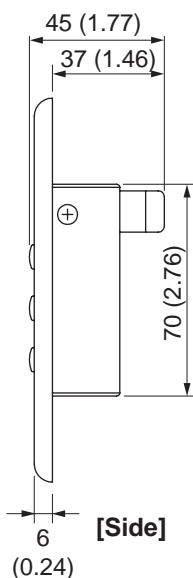

[Side]

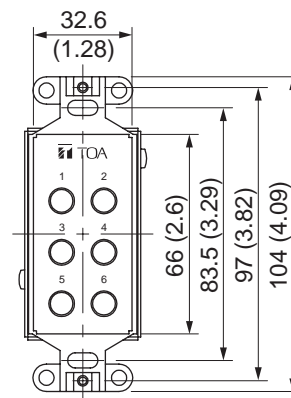

[Front View without panel]

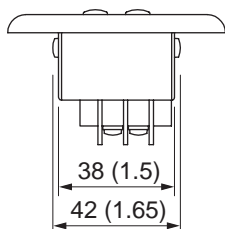

[Bottom]

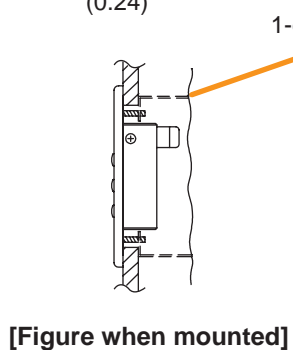

1-gang electrical box (not supplied)

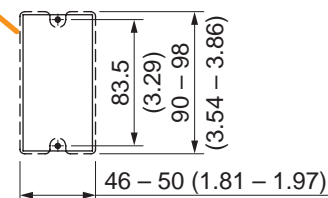

[Dimensions of mounting opening]

18.3. ZM-9002

Unit: mm (in)

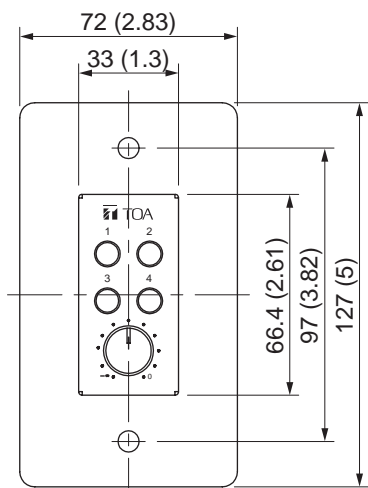

[Front]

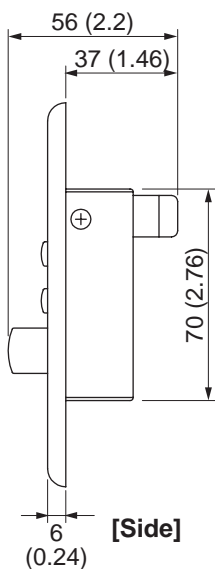

[Side]

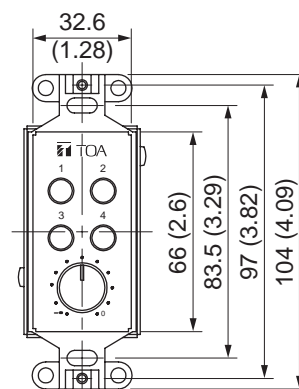

[Front View without panel]

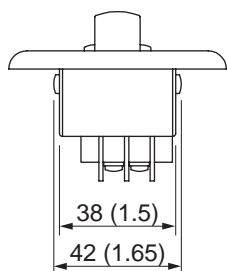

[Bottom]

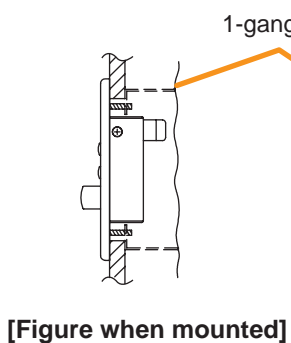

1-gang electrical box (not supplied)

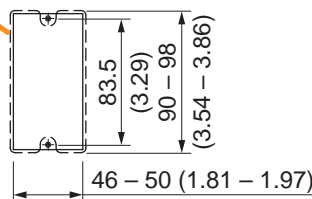

[Dimensions of mounting opening]

18.4. ZM-9003

Unit: mm (in)

[Front]

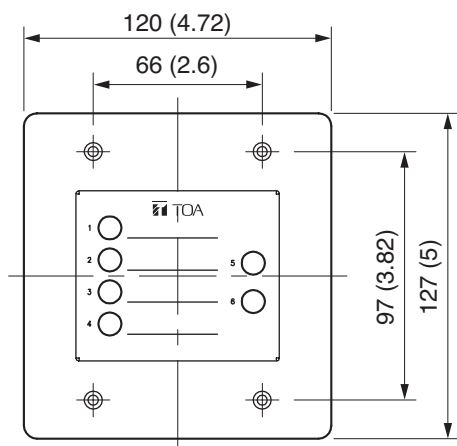

[Side]

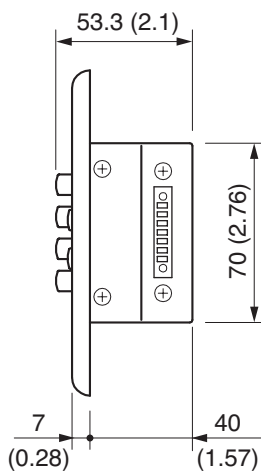

[Rear]

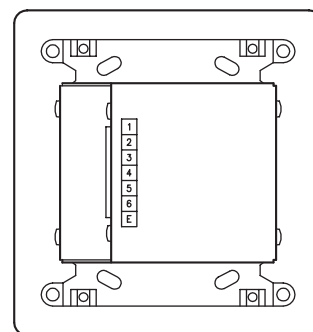

[Bottom]

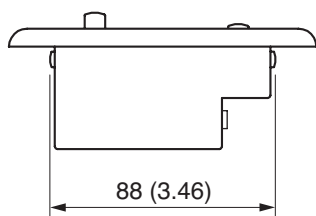

[Figure when mounted]

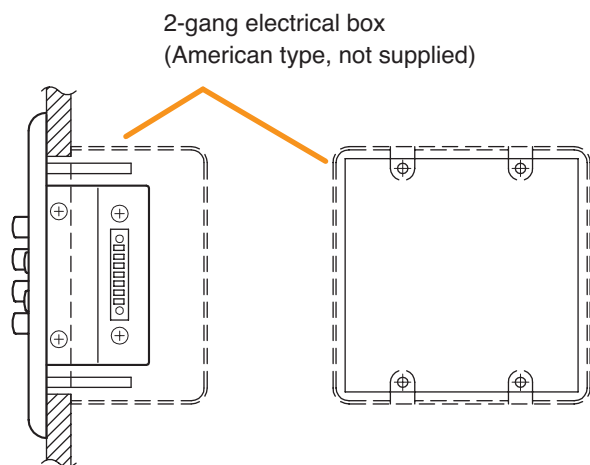

[Front view without panel]

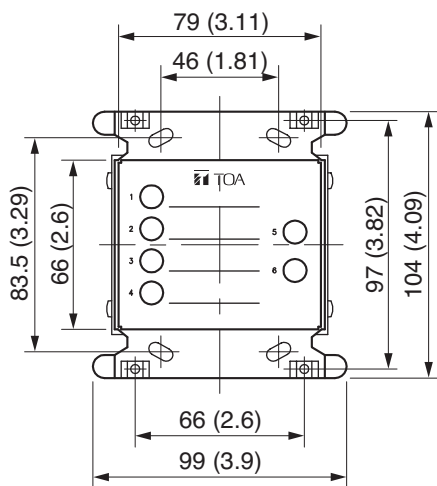

18.5. ZM-9011

Unit: mm (in)

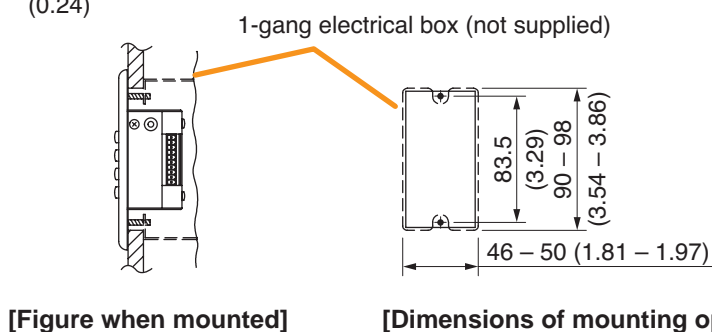
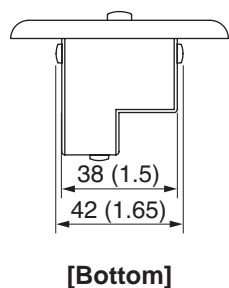
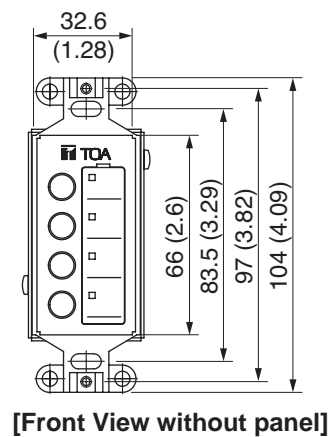
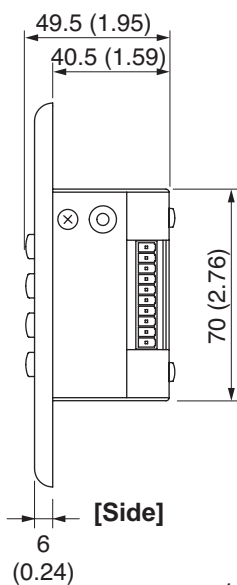
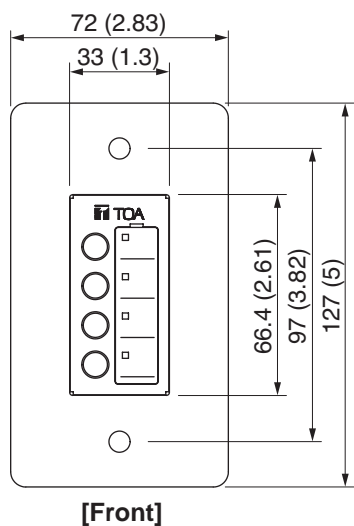

18.6. ZM-9012

Unit: mm (in)

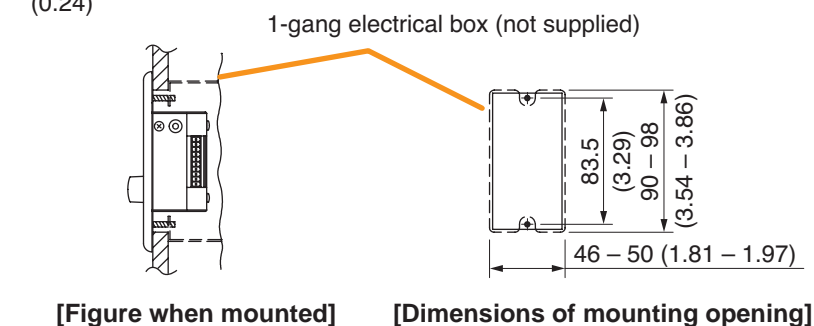
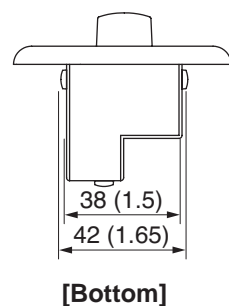
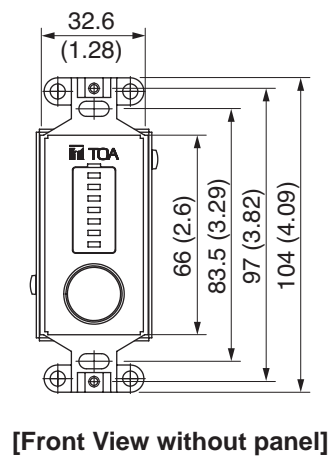
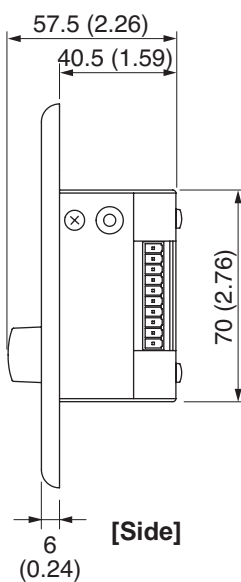
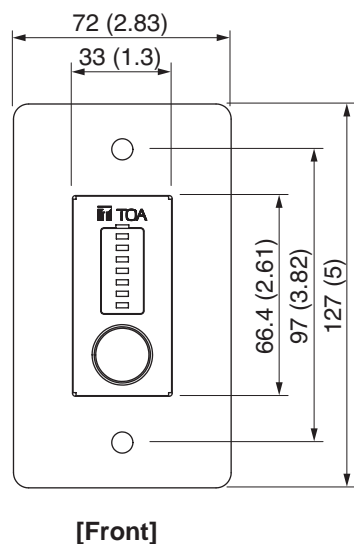

18.7. ZM-9013

Unit: mm (in)

[Front]

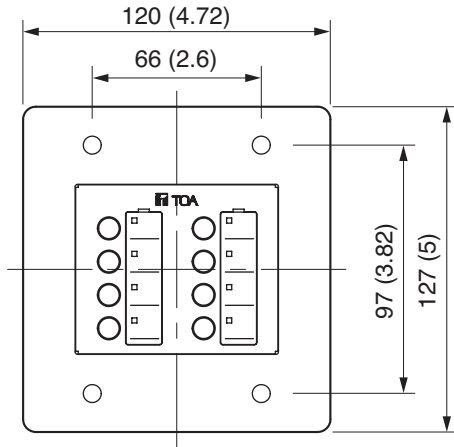

[Side]

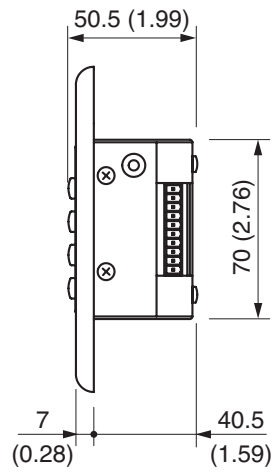

[Rear]

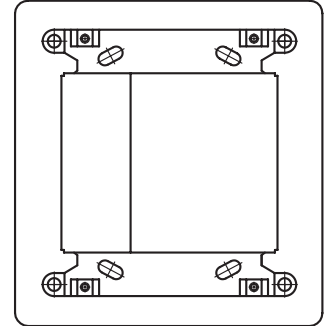

[Bottom]

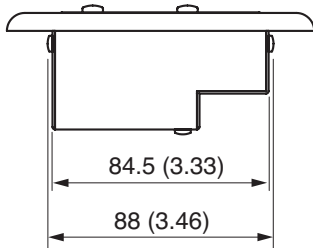

[Figure when mounted]

2-gang electrical box
(American type, not supplied)

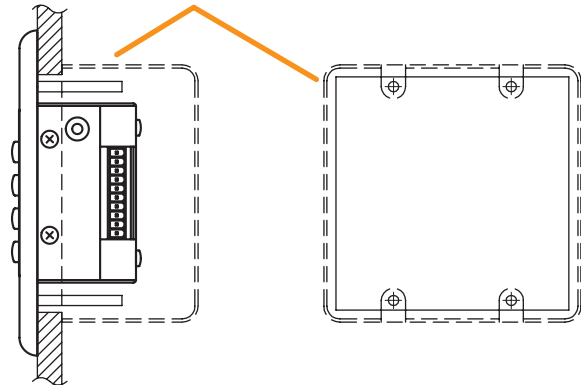

[Front view without panel]

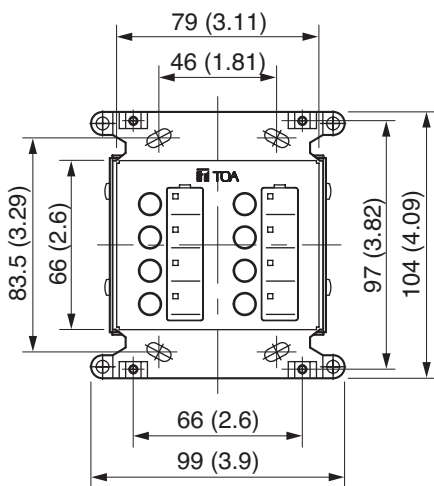

18.8. ZM-9014

Unit: mm (in)

[Front]

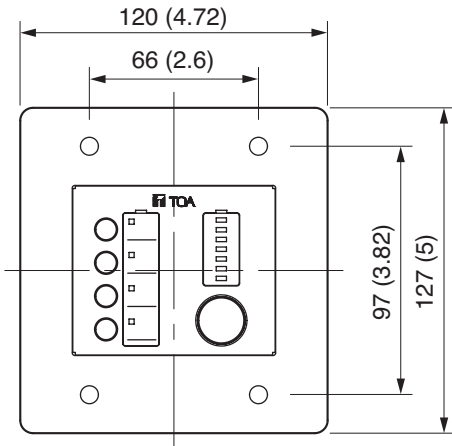

[Side]

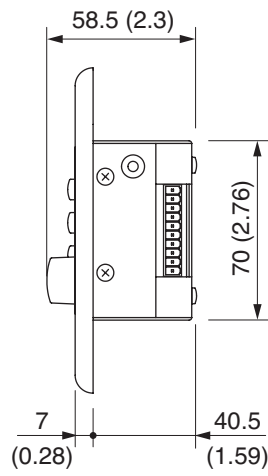

[Rear]

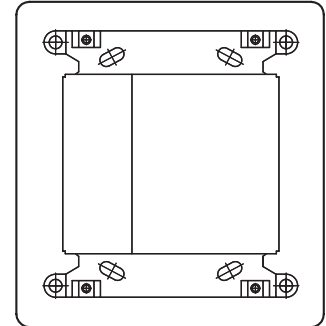

[Bottom]

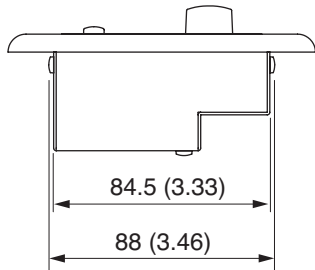

[Figure when mounted]

2-gang electrical box
(American type, not supplied)

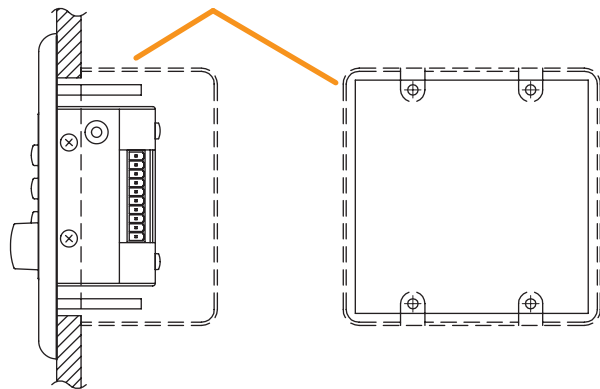

[Front view without panel]

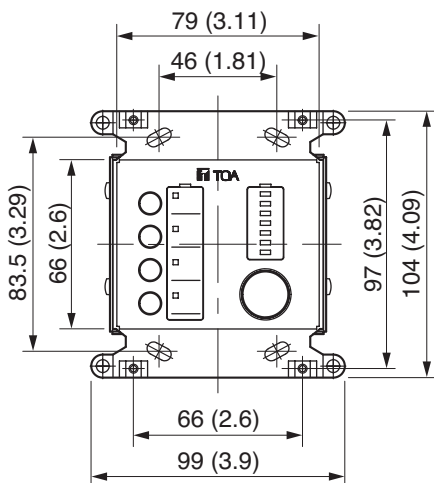

18.9. SS-9001

Unit: mm (in)

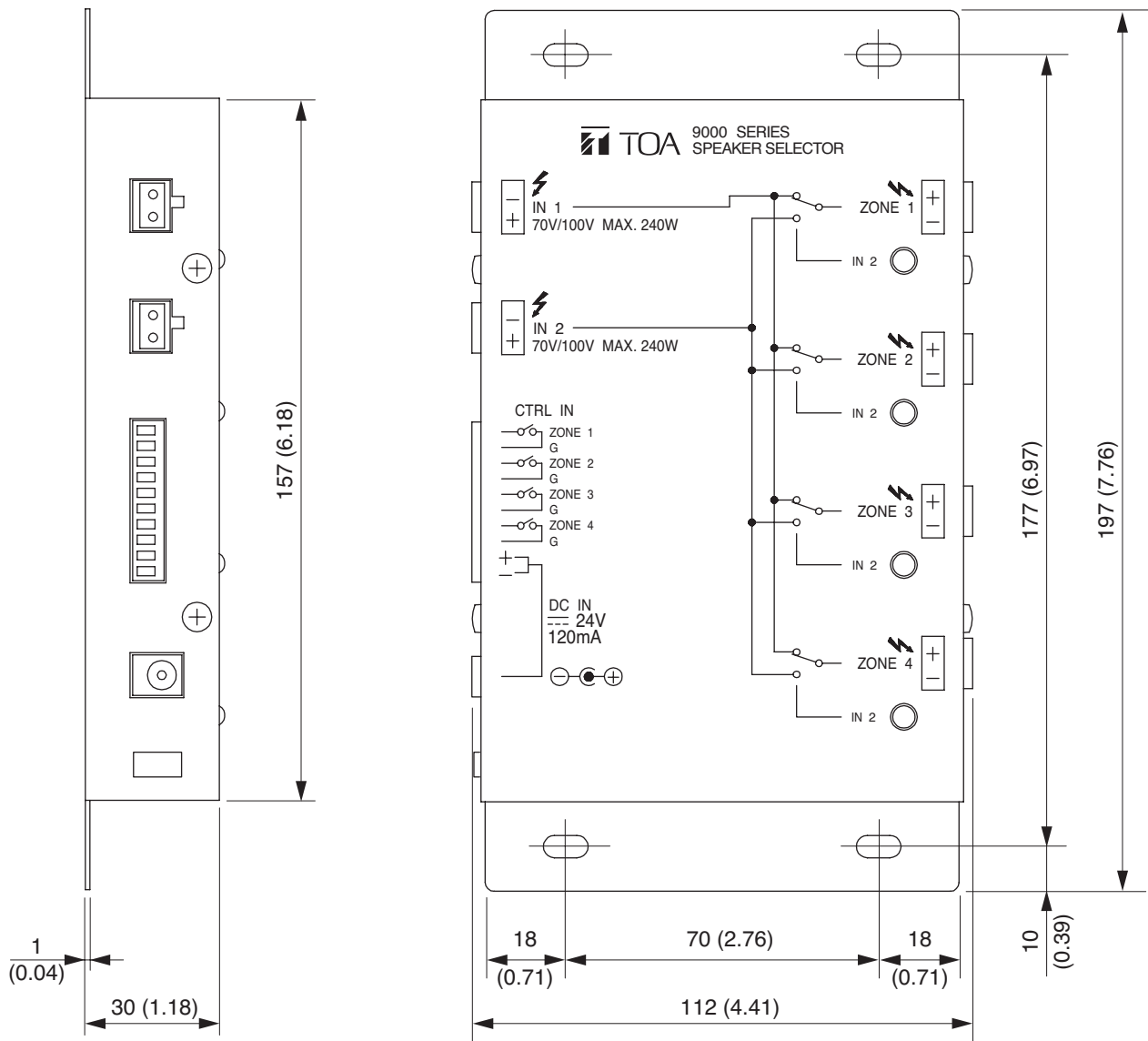

19. OUTLINE OF THE ATTACHED SOFTWARE

The supplied CD-ROM contains the 9000M2 series Setting Software.
This Software is a program used to create setting data and to update a firmware.

[PC system requirement]

The Software runs on Windows XP version above. Ensure that your PC meets the following requirements. The Software will not run properly on non-compliant computers.

- Serial port: RS-232C or use USB-RS-232C conversion cable
- Drive media: CD-ROM

Note: Windows is a trademark of Microsoft Corporation.

Refer to the Setting software manual on how to use the Setting software.

The latest firmware version of the M-9000M2 is made available on the TOA product data download site (<http://www.toa-products.com/international/>). The communication speed is fixed regardless of the setting during firmware update.

20. ERROR INDICATIONS

Error indications	Possible cause and Remedy
MODULE SLOT#No. ERROR	<p>A module is inserted into a wrong slot. Check to confirm that each module is inserted into a correct slot, and correctly reinsert the module inserted into the wrong slot. (Refer to p. 106 "MODULE INSTALLATION.")</p>
DC PROTECT (OUTPUT #No.)	<p>There may be overload or excessive signal input. Check input and output signal levels and gain settings, then adjust them as necessary. If the indicator remains lit, consult your TOA dealer.</p>
THERMAL PROTECT	<p>(1) The unit is heated to a high temperature. Check that the unit is properly installed and Fan functioning. (Refer to p. 11 "INSTALLATION PRECAUTIONS.")</p> <p>(2) Overcurrent due to overload. Remove overload.</p> <p>(3) Short circuit. Check speakers and lines for short circuit.</p> <p>Disconnect the AC cord from the unit, and allow the unit to cool for a while. The unit automatically resumes operation when its inner temperature decreases. If this happens frequently, contact your TOA dealer.</p>
INITIALIZE MEMORY?	<p>Module-to-Slot configuration was changed or a module was damaged. Perform any of the following operations:</p> <p>(1) Press the Enter key. The set parameter in question is reset to the default setting.</p> <p>(2) Press the Memory key. The unit continues to start up. After start-up is completed, back up the set parameters using the supplied software, then confirm the setting in question to correct.</p> <p>(3) Press the Escape/Back key. "MODULE SLOT#No. ERROR" appears indicating the error slot. Reinsert the correct module into the slot.</p>
The Fault indicator lights.	<p>A communication error between the unit and module occurred. Disconnect the AC power supply, then reconnect it. If the indicator remains lit, this may indicate a unit failure. Consult your TOA dealer.</p>
The Fault indicator flashes.	<p>A setting error occurs and a part of or entire data are initialized. The indicator goes off by pressing the arrow key, Input selection key, or Output selection key. Reconfirm the set data.</p>
The Fault indicator continues to flash.	<p>A communication error between the RC-001T Remote and Remote control panel occurred. Check the cables and remote control panel's setting.</p>

21. TROUBLESHOOTING

Symptom	Possible Cause	Remedy
Noise generated.	Module mounting screw not securely tightened.	If this screw is loose, noise may be produced. Ensure that the screw is tightened.
Excessive noise.	Incorrect module input sensitivity setting.	The unit is designed to digitize audio signals with an AD converter and vary the input level with a digital volume control. Therefore, noise increases if the input or output volume control is set to a level higher than 0 dB while the AD converter input is kept low.
Sound distorted.	Incorrect module input sensitivity setting.	The unit is designed to digitize audio signals with an AD converter and vary the input level with a digital volume control. Therefore, when an extremely large input is fed into the AD converter, the voice remains distorted even if the volume is decreased.
Phantom power not supplied.	D-001T module mounting screw not securely tightened. (D-001R cannot supply phantom power irrespective of its ON/OFF setting.)	If this screw is loose, phantom power is not supplied. Ensure that the module mounting screw is tightened.
	Phantom power set to OFF in D-001T module input setting. (D-001R cannot supply phantom power irrespective of its ON/OFF setting.)	If phantom power is set to OFF in D-001T module input setting, phantom power is not supplied. Set phantom power to ON in the input setting.
Condenser microphone does not operate correctly.	Condenser microphone of the type powered by over +24 V is used.	The D-001T module's phantom power supplies +24 V. If using a condenser microphone powered by over +24 V, separately prepare phantom power supply equipment recommended by the equipment manufacturer.
Amplifier malfunctioned (does not operated as intended.)	Incorrect item or parameter setting.	Check the related setting items and set contents.
Only a part of the settings does not work correctly.	Incorrect type of module selected or module inserted into incorrect slot.	Check the related setting items and set contents.
Zone manger and Remote control panel do not work.	Incorrect type of Zone manager or Remote control panel selected or incorrect ID set.	Check the related setting items and set contents.
	A higher-priority broadcast in progress.	A higher-priority broadcast being made when the indicator of the paging activation function-assigned SW flashing.

22. BLOCK DIAGRAM

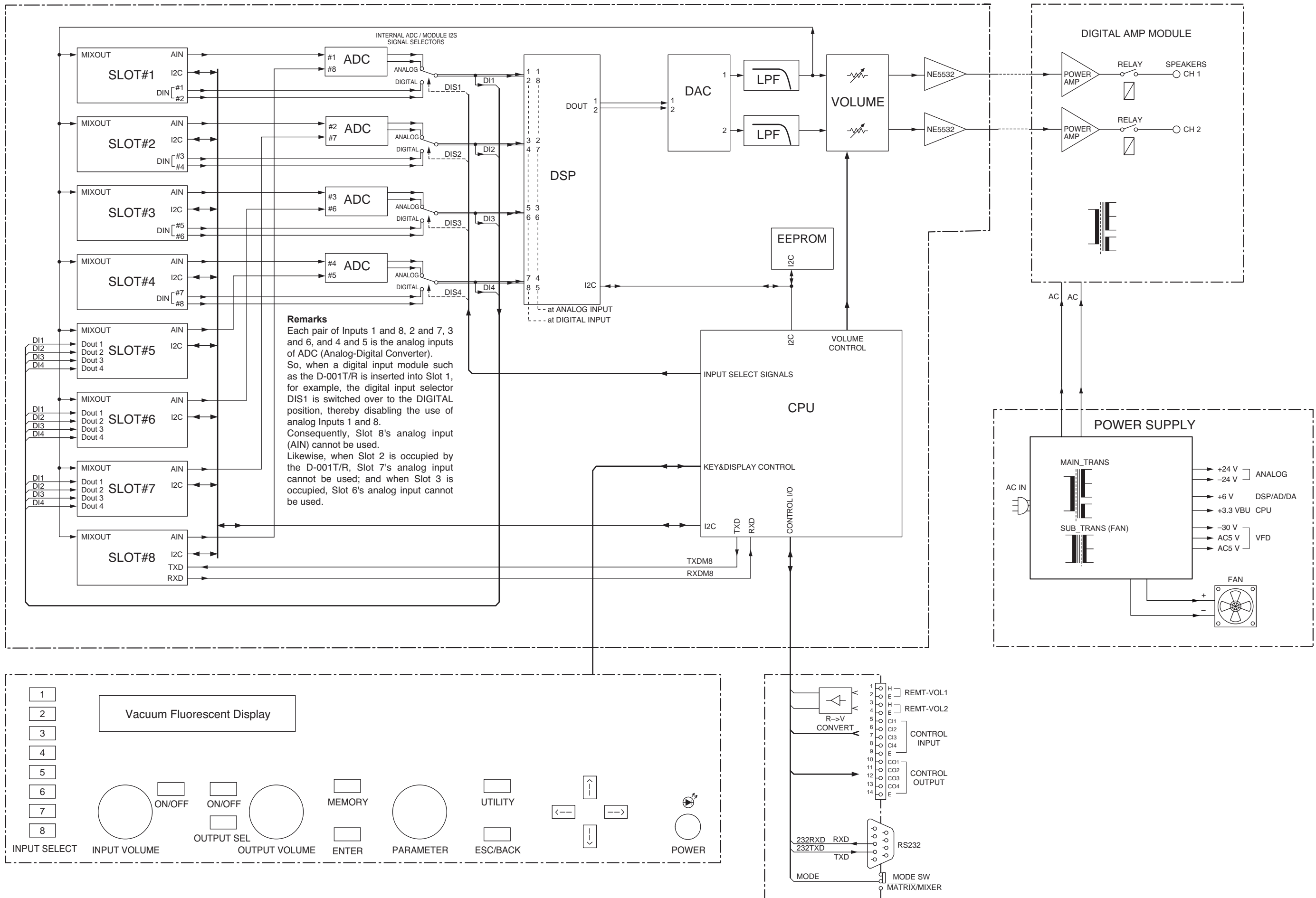

23. SIGNAL FLOW DIAGRAM

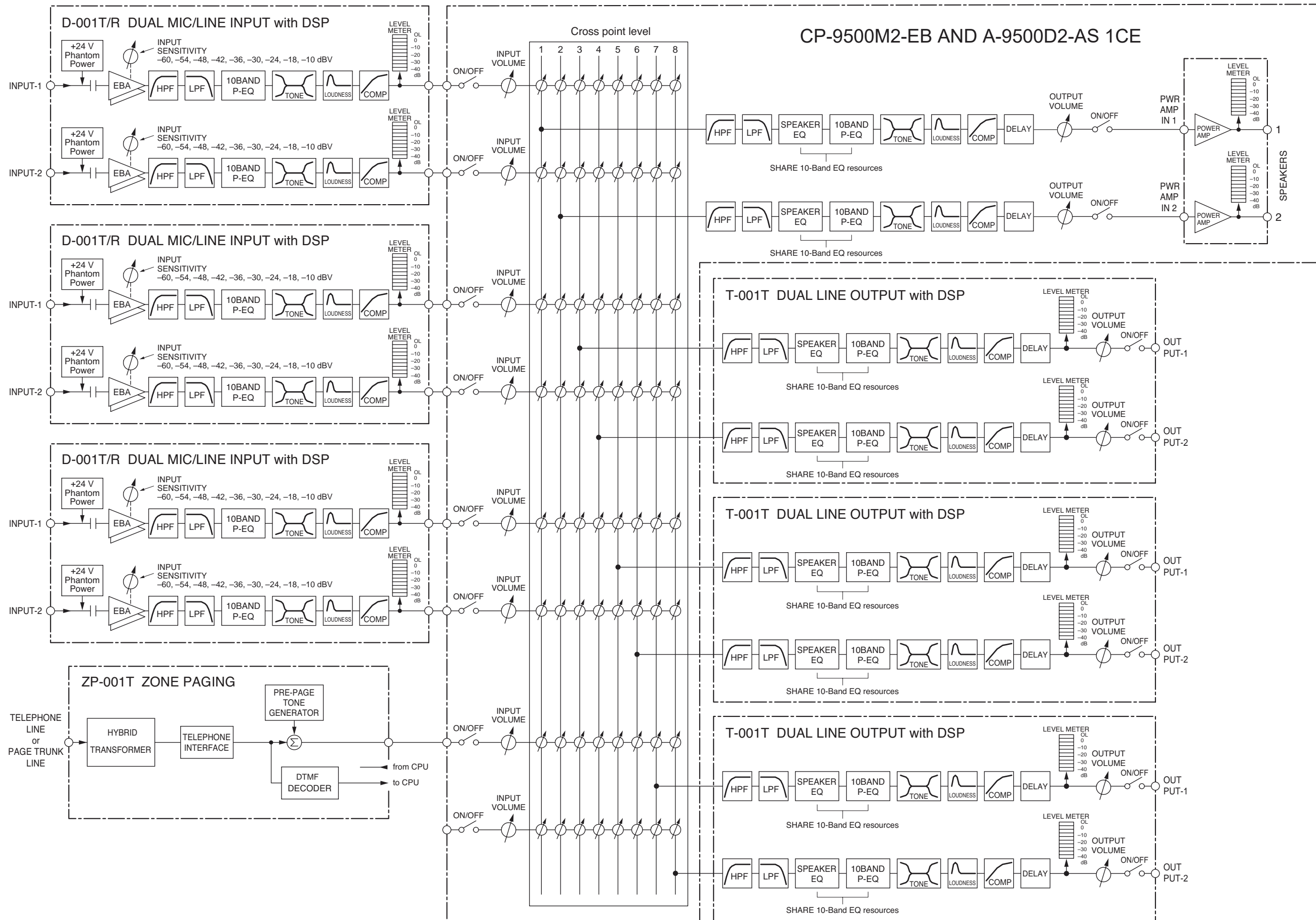

24. LEVEL DIAGRAM

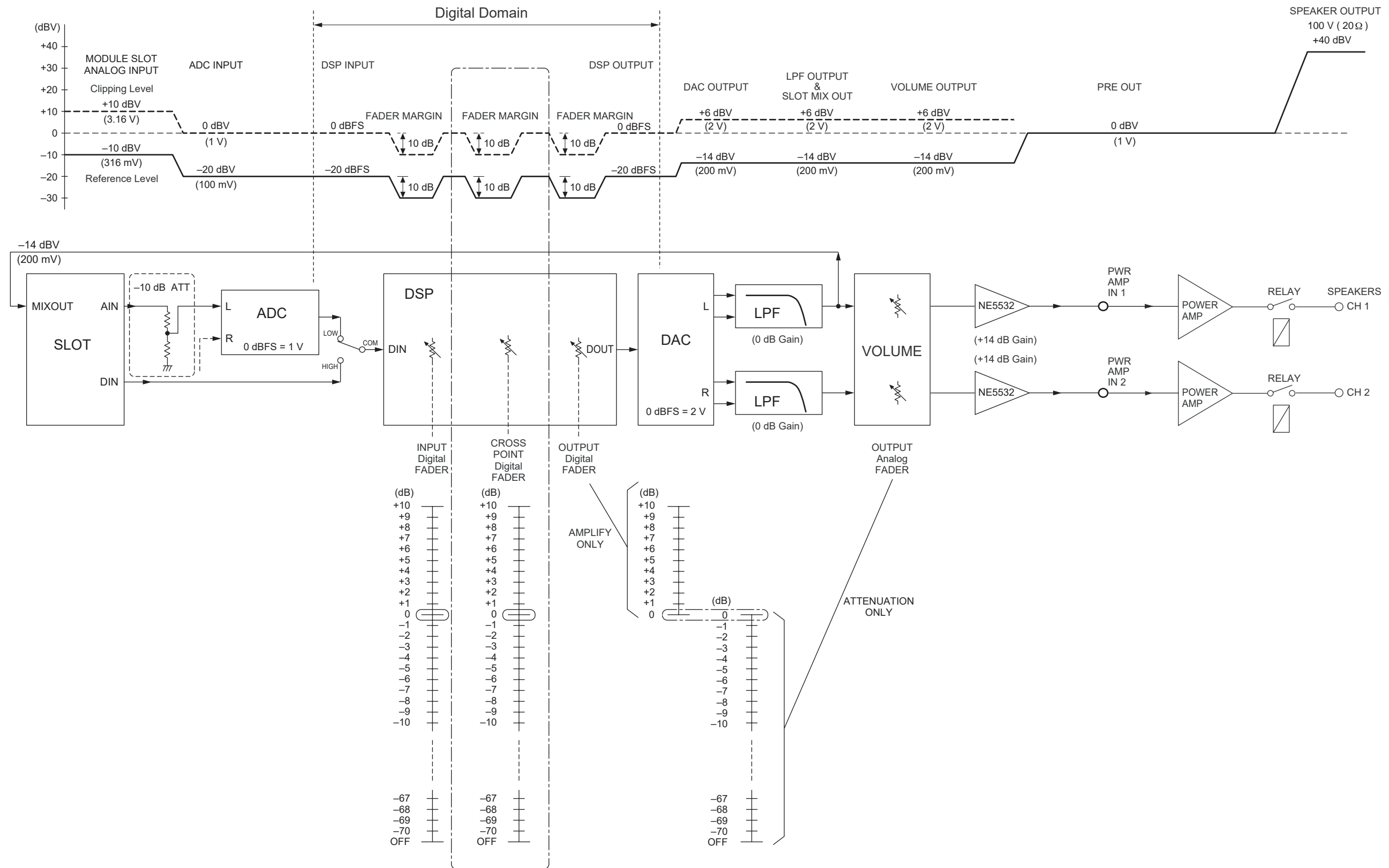

25. COMPRESSOR CHARACTERISTICS DIAGRAM

LINK A
LINK B
The diagram below shows the compression characteristics on p. 60-A13 or p. 73-B8.

COMPRESSOR

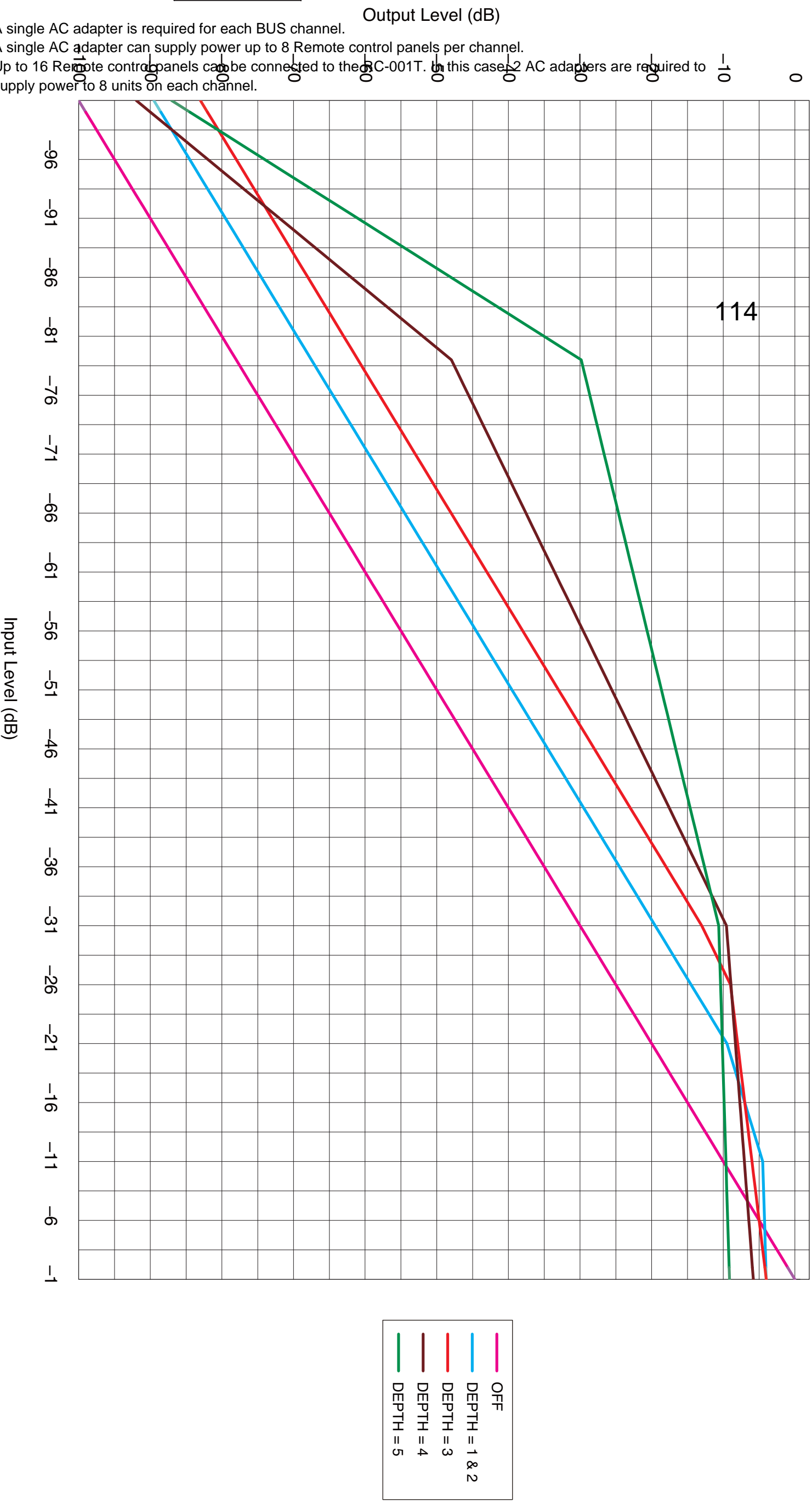

26. SPEAKER PRESET PARAMETER LIST

Described here are parameters that can be used for the speaker parameter presetting screen (p. 69 and 71). Depending on the speaker models such as F-1000, F-1300, F-2000, and SR-T5, "ALL FLAT" parameter is recommended to be set as general use. However, set EQ parameters according to the installation environment.

*1 Combination of specified speaker and subwoofer

	F-122			F-122 LOWCUT*1		
	GAIN (dB)	FREQ (Hz)	Q	GAIN (dB)	FREQ (Hz)	Q
EQ 01	HPF	37.5	0.5	HPF	45	0.5
EQ 02	HPF	37.5	0.7	HPF	45	0.7
EQ 03	+11.5	85	2.871	+6.5	80	1.414
EQ 04	-2.5	212	0.667	-4.5	180	0.667
EQ 05	-8	900	2.871	-8	900	2.871
EQ 06	+8	10 k	0.267	+8	11.2 k	0.267
EQ 07	LPF	20 k	0.7	LPF	20 k	0.7
EQ 08	Settable EQ bands in the EQ setting screen			Settable EQ bands in the EQ setting screen		
EQ 09						
EQ 10						

	H-1			H-1 LOWCUT*1		
	GAIN (dB)	FREQ (Hz)	Q	GAIN (dB)	FREQ (Hz)	Q
EQ 01	HPF	118	0.707	HPF	118	0.707
EQ 02	+10	125	1.8	+4	125	1.8
EQ 03	-6.5	220	1.414	-6.5	220	1.414
EQ 04	+1.5	5 k	0.305	+1.5	5 k	0.305
EQ 05	LPF	15.8 k	0.5	LPF	15.8 k	0.5
EQ 06	Settable EQ bands in the EQ setting screen			Settable EQ bands in the EQ setting screen		
EQ 07						
EQ 08						
EQ 09						
EQ 10						

	H-2			H-2 LOWCUT*1		
	GAIN (dB)	FREQ (Hz)	Q	GAIN (dB)	FREQ (Hz)	Q
EQ 01	HPF	63	0.707	HPF	63	0.707
EQ 02	+10	100	1.871	+2.5	100	1.871
EQ 03	-5	200	1.414	-5	200	1.414
EQ 04	+1.5	5 k	0.305	+1.5	5 k	0.305
EQ 05	LPF	15.8 k	0.5	LPF	15.8 k	0.5
EQ 06	Settable EQ bands in the EQ setting screen			Settable EQ bands in the EQ setting screen		
EQ 07						
EQ 08						
EQ 09						
EQ 10						

	H-3			H-3 LOWCUT*1		
	GAIN (dB)	FREQ (Hz)	Q	GAIN (dB)	FREQ (Hz)	Q
EQ 01	HPF	63	0.707	HPF	63	0.707
EQ 02	+9	100	2.871	+5	100	2.871
EQ 03	-8	220	2.871	-8	220	2.871
EQ 04	+5	500	2.871	+5	500	2.871
EQ 05	+1.5	5 k	0.305	+1.5	5 k	0.305
EQ 06	Settable EQ bands in the EQ setting screen			Settable EQ bands in the EQ setting screen		
EQ 07						
EQ 08						
EQ 09						
EQ 10						

	HB-1		
	GAIN (dB)	FREQ (Hz)	Q
EQ 01	HPF	40	1
EQ 02	LPF	100	1
EQ 03	Settable EQ bands in the EQ setting screen		
EQ 04			
EQ 05			
EQ 06			
EQ 07			
EQ 08			
EQ 09			
EQ 10			

	FB-100		
	GAIN (dB)	FREQ (Hz)	Q
EQ 01	HPF	40	1
EQ 02	LPF	100	1
EQ 03	Settable EQ bands in the EQ setting screen		
EQ 04			
EQ 05			
EQ 06			
EQ 07			
EQ 08			
EQ 09			
EQ 10			

	SW for F-122*2		
	GAIN (dB)	FREQ (Hz)	Q
EQ 01	LPF	100	0.5
EQ 02	+2.5	112	0.667
EQ 03	Settable EQ bands in the EQ setting screen		
EQ 04			
EQ 05			
EQ 06			
EQ 07			
EQ 08			
EQ 09			
EQ 10			

	SR-S4*3		
	GAIN (dB)	FREQ (Hz)	Q
EQ 01	HPF	60	1.226
EQ 02	+5	16 k	1.414
EQ 03	Settable EQ bands in the EQ setting screen		
EQ 04			
EQ 05			
EQ 06			
EQ 07			
EQ 08			
EQ 09			
EQ 10			

*2 Subwoofer for F-122

*3 SR-S4 driven by a single amplifier

	HX-5*4			HX-5 LOWCUT*1		
	GAIN (dB)	FREQ (Hz)	Q	GAIN (dB)	FREQ (Hz)	Q
EQ 01	HPF	60	2.053	HPF	90	1.307
EQ 02	2	65	1.414	-3	800	0.7
EQ 03	-3	800	0.7	-4	2500	2.997
EQ 04	-4	2500	2.997	5	5000	0.305
EQ 05	5	5000	0.305	Settable EQ bands in the EQ setting screen		
EQ 06	Settable EQ bands in the EQ setting screen					
EQ 07						
EQ 08						
EQ 09						
EQ 10						

*4 HX-5 Series

	FB-120*5		
	GAIN (dB)	FREQ (Hz)	Q
EQ 01	HPF	40	2.053
EQ 02	LPF	100	1
EQ 03	Settable EQ bands in the EQ setting screen		
EQ 04			
EQ 05			
EQ 06			
EQ 07			
EQ 08			
EQ 09			
EQ 10			

	F-1522		
	GAIN (dB)	FREQ (Hz)	Q
EQ 01	HPF	50	0.5
EQ 02	5	80	1.414
EQ 03	-3.5	206	2.871
EQ 04	-3	690	4.063
EQ 05	-3	1.4 k	2.997
EQ 06	-6	2.18 k	2.371
EQ 07	4	8 k	1.011
EQ 08	LPF	20 k	0.707
EQ 09	Settable EQ bands in the EQ setting screen		
EQ 10			

*5 FB-120 Series

	FB-2322		
	GAIN (dB)	FREQ (Hz)	Q
EQ 01	HPF	28	0.5
EQ 02	HPF	28	0.707
EQ 03	8	85	2.215
EQ 04	-4	200	2.871
EQ 05	-7	900	2.215
EQ 06	-4	3 k	1.414
EQ 07	7.5	6.7 k	0.511
EQ 08	-4	7.5 k	4.938
EQ 09	LPF	20 k	0.707
EQ 10	Settable EQ band in the EQ setting screen		

	FB-2352		
	GAIN (dB)	FREQ (Hz)	Q
EQ 01	HPF	30	0.707
EQ 02	HPF	30	0.5
EQ 03	6	80	2.215
EQ 04	-3.5	195	2.871
EQ 05	-3	850	2.871
EQ 06	7	6 k	1.011
EQ 07	-2	2.18 k	2.871
EQ 08	-4	7.5k	4.938
EQ 09	LPF	20 k	0.5
EQ 10	Settable EQ band in the EQ setting screen		

	FB-2852		
	GAIN (dB)	FREQ (Hz)	Q
EQ 01	HPF	30	0.707
EQ 02	HPF	28	0.707
EQ 03	6	80	1.985
EQ 04	-3	125	3.134
EQ 05	-5.5	206	3.134
EQ 06	-2	900	4.318
EQ 07	-4	1.7 k	0.667
EQ 08	8	7.3 k	0.49
EQ 09	LPF	20 k	0.707
EQ 10	Settable EQ band in the EQ setting screen		

	SR-H2S		
	GAIN (dB)	FREQ (Hz)	Q
EQ 01	HPF	20	0.5
EQ 02	+7	100	1
EQ 03	-7	250	1.4
EQ 04	-3	3 k	1
EQ 05	4	8 k	1
EQ 06	Settable EQ bands in the EQ setting screen		
EQ 07			
EQ 08			
EQ 09			
EQ 10			

	SR-H2L		
	GAIN (dB)	FREQ (Hz)	Q
EQ 01	HPF	20	0.5
EQ 02	+7	100	1
EQ 03	-7	250	1.4
EQ 04	-6	3 k	1
EQ 05	2	8 k	1
EQ 06	Settable EQ bands in the EQ setting screen		
EQ 07			
EQ 08			
EQ 09			
EQ 10			

	SR-H3S		
	GAIN (dB)	FREQ (Hz)	Q
EQ 01	HPF	20	0.5
EQ 02	+7	100	1
EQ 03	-8	250	1.4
EQ 04	-7	3 k	1
EQ 05	4	8 k	1
EQ 06	Settable EQ bands in the EQ setting screen		
EQ 07			
EQ 08			
EQ 09			
EQ 10			

	SR-H3L		
	GAIN (dB)	FREQ (Hz)	Q
EQ 01	HPF	20	0.5
EQ 02	+7	100	1
EQ 03	-8	250	1.4
EQ 04	-4	3 k	1
EQ 05	6	8 k	1
EQ 06	Settable EQ bands in the EQ setting screen		
EQ 07			
EQ 08			
EQ 09			
EQ 10			

	HS-120		
	GAIN (dB)	FREQ (Hz)	Q
EQ 01	HPF	50	1.618
EQ 02	-5	580	3.134
EQ 03	-4	1500	4.318
EQ 04	-3	2100	4.983
EQ 05	-2	5500	3.134
EQ 06	2	14000	0.718
EQ 07	Settable EQ bands in the EQ setting screen		
EQ 08			
EQ 09			
EQ 10			

	HS-150		
	GAIN (dB)	FREQ (Hz)	Q
EQ 01	HPF	50	1.45
EQ 02	-4.5	500	1.85
EQ 03	-3	1250	3.45
EQ 04	-5	2900	1.85
EQ 05	-3	6500	1.414
EQ 06	3	14000	0.776
EQ 07	Settable EQ bands in the EQ setting screen		
EQ 08			
EQ 09			
EQ 10			

	HS-1200		
	GAIN (dB)	FREQ (Hz)	Q
EQ 01	HPF	50	1.432
EQ 02	-5	520	1.414
EQ 03	-4	1600	5.764
EQ 04	-3	2100	5.764
EQ 05	-2	5000	1.011
EQ 06	3	14000	1.204
EQ 07	Settable EQ bands in the EQ setting screen		
EQ 08			
EQ 09			
EQ 10			

	HS-1500		
	GAIN (dB)	FREQ (Hz)	Q
EQ 01	HPF	50	1.274
EQ 02	-5	530	2.145
EQ 03	-4	1300	2.871
EQ 04	-3	2100	2.871
EQ 05	-2	4500	1.011
EQ 06	1.5	14000	0.718
EQ 07	Settable EQ bands in the EQ setting screen		
EQ 08			
EQ 09			
EQ 10			

	F-1000 LOWCUT*1		
	GAIN (dB)	FREQ (Hz)	Q
EQ 01	HPF	80	1
EQ 02	-5	200	3
EQ 03	Settable EQ bands in the EQ setting screen		
EQ 04			
EQ 05			
EQ 06			
EQ 07			
EQ 08			
EQ 09			
EQ 10			

	F-1300 LOWCUT*1		
	GAIN (dB)	FREQ (Hz)	Q
EQ 01	HPF	80	1
EQ 02	-3	170	3
EQ 03	Settable EQ bands in the EQ setting screen		
EQ 04			
EQ 05			
EQ 06			
EQ 07			
EQ 08			
EQ 09			
EQ 10			

	F-2000 LOWCUT*1		
	GAIN (dB)	FREQ (Hz)	Q
EQ 01	HPF	80	1
EQ 02	-3	130	3
EQ 03	Settable EQ bands in the EQ setting screen		
EQ 04			
EQ 05			
EQ 06			
EQ 07			
EQ 08			
EQ 09			
EQ 10			

27. SPECIFICATIONS

27.1. CP-9500M2-EB AND A-9500D2-AS 1CE

Power Source	220 – 240 V AC, 50/60 Hz
Power Consumption	220 W
Audio Input	Max. 8 channels, modular construction* ¹
Speaker Output 1, 2	100V、500W、20Ω、M4 screw terminal
Amplification system	Class D
Module Slot	Analog input (slot 1 – 8): –10 dB* ² , 10 kΩ, unbalanced Digital input (slot 1 – 4): 24 bit/48 kHz MIX output (slot 1 – 8): –14 dB* ² , 330 Ω (CH1 prefader output), unbalanced Digital output (slot 5 – 7): 24 bit/48 kHz Power supply (slot 1 – 8): +24 V, –24 V, +6 V DC
Digital Audio Signal Reference Level	–20 dB FS
Frequency Response	20 Hz – 20 kHz, +1, -3 dB
Total Harmonic Distortion	0.3%
S/N Ratio	At Input short, A-weighted, ALL FLAT or OFF setting Output volume min.: 85 dB Output volume max.: 61 dB (input 1 volume: 0 dB, other inputs: OFF)
Cross Talk	Over 60 dB (at 20 kHz)
Tone Control	Bass: ±12 dB (at 100 Hz), Treble: ±12 dB (at 10 kHz)
Parametric Equalizer	10 bands, Frequency: 20 Hz – 20 kHz, 31 points, Variable range: ±12 dB, Q: 0.3 – 5
Speaker Equalizer	10 (PC software has 30 TOA speaker presets.)
High-pass Filter	–12 dB/oct, Variable frequency range: 20 Hz – 20 kHz, 31 points
Low-pass Filter	–12 dB/oct, Variable frequency range: 20 Hz – 20 kHz, 31 points
Compressor	Depth: 1 – 5
Delay	0 – 40 ms (1 ms steps), maximum 40 ms (CH1 + CH2), mixer mode only
Scene Memory	32
Auxiliary Function	Key lock function
Control Input/Output	RS-232C* ³ , D-sub connector (9P, female) Control input: 4 inputs, no-voltage make contact input, open voltage: 3.3 V DC, short-circuit current: under 1 mA, removable terminal block (14 pins) Control output: 4 outputs, open collector output, withstand voltage: 27 V DC, control current: 50 mA, removable terminal block (14 pins) Remote volume: 2 channels, connect a 10 kΩ/linear taper variable resistor or input the DC voltage of 0 to +10 V, removable terminal block (14 pins)
Operating Temperature	–10 to +40°C (14 – 104°F)
Operating Humidity	35% to 80% RH (no condensation)
Finish	Panel: Aluminum, hair-line, black Case: Surface-treated steel plate, black, paint
Dimensions	420 (w) x 107.6 (h) x 415 (d) mm (16.54" x 4.24" x 16.34")
Weight	9.6 kg (21.16 lb)

*¹ Factory slot 1 is already installed D-001T module, other modules must be purchased separately.

*² 0 dB = 1 V

*³ Allowing it to be controlled by a control system such as AMX and Crestron through RS-232C port.

Notes

- The design and specifications are subject to change without notice for improvement.
- AMX is a trademark of AMX Corporation.
- Crestron is a trademark of Crestron Electronics, Inc.

· Accessories

EUR Specifications Power cord	1
UK Specifications Power cord	1 (without A-9500D2-AS 1CE)
Rack mounting bracket	2
Bracket mounting screw (M4 x 16)	4
Removable terminal plug (3 pins)	2
Removable terminal plug (14 pins)	1
CD-ROM	1
Start guide	1
Terminal block cover mounting screw (M4 x 8)	2
Terminal block cover	4

27.2. Optional Modules

27.2.1. D-001T

Power Source	+24 V DC, -24 V DC, +6 V DC
Current Consumption	20 mA (at +24 V DC), 20 mA (at -24 V DC), 75 mA (at +6 V DC)
Input	2 channels, 3 k Ω (when the phantom power is ON) / 10 k Ω (phantom power is OFF), electronically-balanced, removable terminal block (3 pins)
Input Sensitivity	-60, -54, -48, -42, -36, -30, -24, -18, -10 dB* (selectable)
Frequency Response	20 Hz – 20 kHz +1, -3 dB
Total Harmonic Distortion + N	0.01% (at 1 kHz, A-weighted, Input sensitivity: -10 dB)
Input Equivalent Noise	Under -112 dB (at A-weighted, Input short, Input sensitivity: -60 dB)
S/N Ratio	Over 70 dB (at A-weighted, Input short, Input sensitivity: -10 dB)
Cross Talk	Over 75 dB (at 20 kHz, Input sensitivity: -10 dB)
CMRR	Over 62 dB (at 1 kHz, Input sensitivity: -60 dB)
A/D Converter	24 bit $\Delta\Sigma$ ADC
Sampling Frequency	48 kHz
Tone Control	Bass: ± 12 dB (at 100 Hz) Treble: ± 12 dB (at 10 kHz)
Parametric Equalizer	10 bands, Frequency: 20 Hz – 20 kHz, 31 points, Variable range: ± 12 dB, Q: 0.3 – 5
High-pass Filter	-12 dB/oct, Variable frequency range: 20 Hz – 20 kHz, 31 points
Low-pass Filter	-12 dB/oct, Variable frequency range: 20 Hz – 20 kHz, 31 points
Compressor	Depth: 1 – 5
Phantom Power	+24 V DC
Operating Temperature	-10 to +40°C (14 – 104°F)
Finish	Panel: Aluminum, hair-line
Dimensions	35 (w) x 78 (h) x 91.5 (d) mm (1.38" x 3.07" x 3.6")
Weight	84 g (0.19 lb)

* 0 dB = 1 V

Note: The design and specifications are subject to change without notice for improvement.

· Accessories

Removable terminal plug (3 pins)	2
Machine screw M3 x 8	2

27.2.2. D-001R

Power Source	+24 V DC, -24 V DC, +6 V DC
Current Consumption	20 mA (at +24 V DC), 20 mA (at -24 V DC), 75 mA (at +6 V DC)
Input	2 channels, 2 RCA jacks/ch mixed, 10 k Ω , unbalanced, RCA jack
Input Sensitivity	-60, -54, -48, -42, -36, -30, -24, -18, -10 dB* (selectable)
Frequency Response	20 Hz – 20 kHz +1, -3 dB
Total Harmonic Distortion + N	0.01% (at 1 kHz, A-weighted, Input sensitivity: -10 dB)
S/N Ratio	Over 70 dB (at A-weighted, Input short, Input sensitivity: -10 dB)
Cross Talk	Over 75 dB (at 20 kHz, Input sensitivity: -10 dB)
A/D Converter	24 bit $\Delta\Sigma$ ADC
Sampling Frequency	48 kHz
Tone Control	Bass: ± 12 dB (at 100 Hz) Treble: ± 12 dB (at 10 kHz)
Parametric Equalizer	10 bands, Frequency: 20 Hz – 20 kHz, 31 points, Variable range: ± 12 dB, Q: 0.3 – 5
High-pass Filter	-12 dB/oct, Variable frequency range: 20 Hz – 20 kHz, 31 points
Low-pass Filter	-12 dB/oct, Variable frequency range: 20 Hz – 20 kHz, 31 points
Compressor	Depth: 1 – 5
Operating Temperature	-10 to +40°C (14 – 104°F)
Finish	Panel: Aluminum, hair-line
Dimensions	35 (w) x 78 (h) x 91.5 (d) mm (1.38" x 3.07" x 3.6")
Weight	95 g (0.21 lb)

* 0 dB = 1 V

Note: The design and specifications are subject to change without notice for improvement.

• Accessories

Machine screw M3 x 8 2

27.2.3. T-001T

Power Source	+24 V DC, -24 V DC, +6 V DC
Current Consumption	35 mA (at +24 V DC), 35 mA (at -24 V DC), 75 mA (at +6 V DC)
Output	2 channels, max. +20 dB* (at 10 kΩ load), 600 Ω, electronically-balanced, removable terminal block (3 pins)
Frequency Response	20 Hz – 20 kHz +1, -3 dB
Total Harmonic Distortion + N	0.01% (at 1 kHz, A-weighted, 10 kΩ load)
S/N Ratio	Over 73 dB (at A-weighted)
Residual Noise	Under -91 dB (at A-weighted, VOL: -70 dB)
Cross Talk	Over 87 dB (at 20 kHz)
D/A Converter	24 bit ΔΣDAC
Sampling Frequency	48 kHz
Tone Control	Bass: ±12 dB (at 100 Hz) Treble: ±12 dB (at 10 kHz)
Parametric Equalizer	10 bands, Frequency: 20 Hz – 20 kHz, 31 points, Variable range: ±12 dB, Q: 0.3 – 5
Speaker Equalizer	10 (PC software has 30 TOA speaker presets.)
High-pass Filter	-12 dB/oct, Variable frequency range: 20 Hz – 20 kHz, 31 points
Low-pass Filter	-12 dB/oct, Variable frequency range: 20 Hz – 20 kHz, 31 points
Compressor	Depth: 1 – 5
Delay	0 – 40 ms (1 ms step), maximum 40 ms (CH1 + CH2), mixer mode only
Operating Temperature	-10 to +40°C (14 – 104°F)
Finish	Panel: Aluminum, hair-line
Dimensions	35 (w) x 78 (h) x 91.5 (d) mm (1.38" x 3.07" x 3.6")
Weight	84 g (0.19 lb)

* 0 dB = 1 V

Note: The design and specifications are subject to change without notice for improvement.

• Accessories

- Removable terminal plug (3 pins) 2
- Machine screw M3 x 8 2

27.2.4. C-001T

Power Source	6 V DC
Current Consumption	15 mA
Control Input	8 channels, open voltage: 3.3 V DC, short-circuit: under 1 mA, removable terminal block (9 pins)
Control Output	8 channels, open collector output, withstand voltage: 27 V DC, control current: max. 50 mA, removable terminal block (9 pins)
Operating Temperature	-10 to +40°C (14 – 104°F)
Finish	Panel: Aluminum, hair-line
Dimensions	35 (w) x 78 (h) x 91.5 (d) mm (1.38" x 3.07" x 3.6")
Weight	62 g (0.14 lb)

Note: The design and specifications are subject to change without notice for improvement.

• Accessories

Removable terminal plug (9 pins)	2
Machine screw M3 x 8	2

27.2.5. ZP-001T

Power Source	+24 V DC, +6 V DC
Current Consumption	38 mA (at +24 V DC), 18 mA (at +6 V DC)
Number of Lines	1 line
Type of Selectable Signal	DTMF signal
Signaling System	Loop-Start (or Ground-Start, selectable)
TEL Line	0 dB, 600 Ω, balanced, transformer-isolated, RJ-11 connector, loop voltage: 24 V DC or more, which should be supplied from the PABX.
Paging Input	0 dB, 600 Ω, balanced, transformer-isolated audio input, removable terminal block (4 pins)
Control Input	1 channel, no-voltage make contact, open voltage: 5 V DC, short-circuit: 0.5 mA, removable terminal block (4 pins)
Control Output	4 channels, open collector output (isolated), withstand voltage: 35 V DC, control current: max. 50 mA, removable terminal block (4 pins)
Operating Temperature	-10 to +40°C (14 – 104°F)
Finish	Panel: Aluminum, hair-line
Dimensions	35 (w) x 78 (h) x 91.5 (d) mm (1.38" x 3.07" x 3.6")
Weight	153 g (0.34 lb)

Note: The design and specifications are subject to change without notice for improvement.

• Accessories

Removable terminal plug (4 pins)	3
Machine screw M3 x 8	2

27.2.6. AN-001T

Power Source	+24 V DC, -24 V DC, +6 V DC
Current Consumption	20 mA (at +24 V DC), 20 mA (at -24 V DC), 75 mA (at +6 V DC)
Input	Sensor input (Ambient noise sensor microphone input): 2 channels, 3 k Ω (when the phantom power is ON)/10 k Ω (when the phantom power is OFF), electronically-balanced, removable terminal block (3 pins)
Input Sensitivity	-60, -54, -48, -42, -36, -30, -24, -18, -10 dB* (selectable)
Phantom Power	+24 V DC
A/D Converter	24 bit $\Delta\Sigma$ ADC
Sampling Frequency	48 kHz
Ambient Noise Control Function	Sensor input reference level adjustment function Maximum output signal level control: -15 to 0 dB Minimum output signal level control: -18 to -3 dB Sample time setting: 10 s, 15 s, 20 s, 30 s, 1 min, 2 min, 3 min, 5 min Gain ratio setting (Ambient noise to Output signal level): 6:3, 5:3, 4:3, 3:3, 3:4, 3:5, 3:6, 6:-3, 5:-3, 4:-3, 3:-3, 3:-4, 3:-5, 3:-6
Operating Temperature	-10 to +40°C (14 - 104°F)
Finish	Panel: Aluminum, hair-line
Dimensions	35 (w) x 78 (h) x 91.5 (d) mm (1.38" x 3.07" x 3.6")
Weight	84 g (0.19 lb)

* 0 dB = 1 V

Note: The design and specifications are subject to change without notice for improvement.

• Accessories

Removable terminal plug (3 pins)	2
Machine screw M3 x 8	2

27.2.7. RC-001T

Power Source	6 V DC
Current Consumption	40 mA or less
Terminal	Removable terminal block (10 pins)
Power Input	24 V DC input x 2 (Applicable AC adapter: optional AD-246, power supply to Remote Controllers) Adaptable DC plug: 9.5 (L) x 5.5 (OD) x 2.1 (ID) mm (0.37" x 0.22" x 0.08")
Operating Temperature	-10 to +40°C (14 - 104°F)
Operating Humidity	35% to 80%RH (no condensation)
Connection Cable	Shielded CPEV cable (paired data line and paired power line) or Category 5 twisted pair cable for LAN (CAT5-STP)
Maximum cable distance	800 m in total
Connectable Number of Remote Control Panels	16 units (2 ports used)
Finish	Panel: aluminum, hair-line
Dimensions	35 (w) x 78 (h) x 91.5 (d) mm (1.38" x 3.07" x 3.6")
Weight	80 g (0.18 lb)

Note: The design and specifications are subject to change without notice for improvement.

• Accessories

Module mounting screw	2
Removable terminal plug (10 pins)	1

27.3. Optional Accessories

27.3.1. AN-9001

Type	Electret condenser microphone
Phantom Power	14 – 26 V DC
Current Consumption	7 mA (at 24 V DC)
Directivity	Omnidirectional (hemispherical)
Impedance	200 Ω
Rated Sensitivity	-5 dB (1 kHz, 0 dB = 1 V/Pa)
Frequency Response	100 Hz – 10 kHz
Output Terminal	Removable terminal block (3 pins)
Operating Temperature	-10 to +40°C (14 – 104°F)
Finish	Panel: ABS resin, white Frame, Case: Surface-treated steel plate
Dimensions	\varnothing 130 x 37 (d) mm (\varnothing 5.12" x 1.46")
Weight	170 g (0.37 lb)

Note: The design and specifications are subject to change without notice for improvement.

• Accessories

Removable terminal plug (3 pins)	1
Machine screw No. 6-32 UNC x 30	2
Machine screw M4 x 30	2

27.3.2. ZM-9001

Applicable Cable	Single conductor shielded cable
Line Resistance	50 Ω or less (per line)
Terminal	M3 screw terminal, distance between barriers: 7.62 mm
Operating Section	6 control buttons
Operating Temperature	-10 to +40°C (14 – 104°F)
Finish	Surface-treated steel plate, white, paint
Dimensions	72 (w) x 127 (h) x 45 (d) mm (2.83" x 5" x 1.77")
Weight	170 g (0.37 lb)

Note: The design and specifications are subject to change without notice for improvement.

• Accessories

Machine screw (for box mounting) No.6-32UNC x 30	2
Machine screw (for box mounting) M4 x 30	2
Machine screw (for panel mounting) No.6-32UNC x 6	2

27.3.3. ZM-9002

Applicable Cable	Single conductor shielded cable
Line Resistance	50 Ω or less (per line)
Terminal	M3 screw terminal, distance between barriers: 7.62 mm
Operating Section	4 control buttons, 1 volume control
Operating Temperature	-10 to +40°C (14 – 104°F)
Finish	Surface-treated steel plate, white, paint
Dimensions	72 (w) x 127 (h) x 56 (d) mm (2.83" x 5" x 2.2")
Weight	170 g (0.37 lb)

Note: The design and specifications are subject to change without notice for improvement.

• Accessories

Machine screw (for box mounting) No.6-32UNC x 30 2
 Machine screw (for box mounting) M4 x 30 2
 Machine screw (for panel mounting) No.6-32UNC x 6 2

27.3.4. ZM-9003

Line Resistance	250 Ω or less (per line)
Terminal	Removable terminal block (7 pins)
Operating Section	4 control selector buttons (interlocking type) 2 control buttons (momentary type)
Operating Temperature	-10 to +40°C (14 – 104°F)
Finish	Surface-treated steel plate, white, paint
Dimensions	120 (w) x 127 (h) x 53.3 (d) mm (4.72" x 5" x 2.1")
Weight	375 g (0.83 lb)

Note: The design and specifications are subject to change without notice for improvement.

• Accessories

Machine screw (for box mounting) No.6-32UNC x 30 4
 Machine screw (for box mounting) M4 x 30 4
 Machine screw (for panel mounting) No.6-32UNC x 6 4
 Removable terminal plug (7 pins) 1

27.3.5. ZM-9011

Power Source	24 V DC (supplied from RC-001T)
Current Consumption	40 mA or less
Terminal	Removable terminal block (10 pins)
Connection Cable	Shielded CPEV cable (paired data line and paired power line) or Category 5 twisted pair cable for LAN (CAT5-STP)
Operating Section	4 control buttons
Indicator	4 function indicators (green LEDs)
Operating Temperature	0 to +40°C (32 – 104°F)
Operating Humidity	35% to 80%RH (no condensation)
Finish	Surface-treated steel panel, white, paint
Dimensions	72 (w) x 127 (h) x 49.5 (d) mm (2.83" x 5" x 1.95")
Weight	160 g (0.35 lb)

Note: The design and specifications are subject to change without notice for improvement.

• Accessories

Box mounting screw (No. 6-32UNC x 30)	2
Box mounting screw (M4 x 30)	2
Panel mounting screw	2
Removable terminal plug (10 pins)	1

27.3.6. ZM-9012

Power Source	24 V DC (supplied from RC-001T)
Current Consumption	40 mA or less
Terminal	Removable terminal block (10 pins)
Connection Cable	Shielded CPEV cable (paired data line and paired power line) or Category 5 twisted pair cable for LAN (CAT5-STP)
Operating Section	1 volume control
Indicator	Set volume level indicators (green LEDs)
Operating Temperature	0 to +40°C (32 – 104°F)
Operating Humidity	35% to 80%RH (no condensation)
Finish	Surface-treated steel panel, white, paint
Dimensions	72 (w) x 127 (h) x 57.5 (d) mm (2.83" x 5" x 2.25")
Weight	160 g (0.35 lb)

Note: The design and specifications are subject to change without notice for improvement.

• Accessories

Box mounting screw (No. 6-32UNC x 30)	2
Box mounting screw (M4 x 30)	2
Panel mounting screw	2
Removable terminal plug (10 pins)	1

27.3.7. ZM-9013

Power Source	24 V DC (supplied from RC-001T)
Current Consumption	40 mA or less
Terminal	Removable terminal block (10 pins)
Connection Cable	Shielded CPEV cable (paired data line and paired power line) or Category 5 twisted pair cable for LAN (CAT5-STP)
Operating Section	8 control buttons
Indicator	8 function indicators (green LEDs)
Operating Temperature	0 to +40°C (32 – 104°F)
Operating Humidity	35% to 80%RH (no condensation)
Finish	Surface-treated steel panel, white, paint
Dimensions	120 (w) x 127 (h) x 50.5 (d) mm (4.72" x 5" x 1.99")
Weight	300 g (0.66 lb)

Note: The design and specifications are subject to change without notice for improvement.

• Accessories

Box mounting screw (No. 6-32UNC x 30)	4
Box mounting screw (M4 x 30)	4
Panel mounting screw	4
Removable terminal plug (10 pins)	1

27.3.8. ZM-9014

Power Source	24 V DC (supplied from RC-001T)
Current Consumption	40 mA or less
Terminal	Removable terminal block (10 pins)
Connection Cable	Shielded CPEV cable (paired data line and paired power line) or Category 5 twisted pair cable for LAN (CAT5-STP)
Operating Section	4 control buttons 1 volume control
Indicator	4 in-use indicators (green LEDs) Set volume level indicators (green LEDs)
Operating Temperature	0 to +40°C (32 – 104°F)
Operating Humidity	35% to 80%RH (no condensation)
Finish	Surface-treated steel panel, white, paint
Dimensions	120 (w) x 127 (h) x 58.5 (d) mm (4.72" x 5" x 2.3")
Weight	300 g (0.66 lb)

Note: The design and specifications are subject to change without notice for improvement.

• Accessories

Box mounting screw (No. 6-32UNC x 30)	4
Box mounting screw (M4 x 30)	4
Panel mounting screw	4
Removable terminal plug (10 pins)	1

27.3.9. SS-9001

Power Source	Supplied from the optional AD-246 AC adapter or an external 24 V DC/200 mA power supply.
Current Consumption	120 mA
Control Signal	No-voltage make contact input (polarized), open voltage: 24 V DC, short-circuit current: 3 mA
Control Power	Under 240 W (70 V/100 V line)
Speaker Terminal	Removable terminal block (2 pins)
Control Terminal	Removable terminal block (10 pins)
Operating Temperature	-10 to +40°C (32 – 104°F)
Finish	Case: Surface-treated steel plate
Dimensions	112 (w) x 197 (h) x 30 (d) mm (4.41" x 7.76" x 1.18")
Weight	530 g (1.17 lb)

Note: The design and specifications are subject to change without notice for improvement.

• Accessories

Removable terminal plug (2 pins)	6
Removable terminal plug (10 pins)	1
Cord clamp	1
Tapping screw 4 x 20	4

Traceability Information for Europe

Manufacturer:
TOA Corporation
7-2-1, Minatojima Nakamachi, Chuo-ku, Kobe, Hyogo,
Japan

Authorized representative:
TOA Electronics Europe GmbH
Suederstrasse 282, 20537 Hamburg,
Germany